



LG

REFRIGERATOR

SERVICE MANUAL

CAUTION
BEFORE SERVICING THE UNIT,
READ THE SAFETY PRECAUTIONS IN THIS MANUAL.

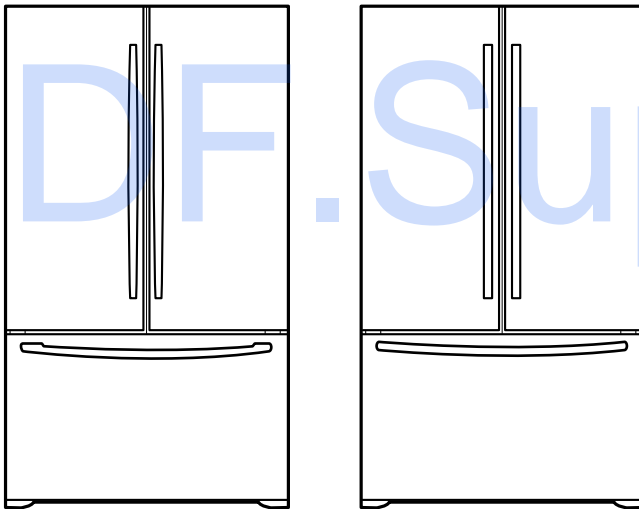

PDF.Support

MODELS: LRFC22750TT
LRFC22750SW
LRFC22750ST

CONTENTS

SAFETY PRECAUTIONS	2
SPECIFICATIONS	3
PARTS IDENTIFICATION	4
DISASSEMBLY	5-7
DOOR.....	5-6
DOOR ALIGNMENT	6
FAN AND FAN MOTOR.....	7
DEFROST CONTROL ASSEMBLY	7
LAMP	7
CONTROL BOX-REFRIGERATOR	7
MULTI DUCT	7
ADJUSTMENT	8-9
COMPRESSOR.....	8
PTC-STARTER.....	8
OLP (OVERLOAD PROTECTOR).....	9
TO REMOVE THE COVER PTC	9
CIRCUIT DIAGRAM	10
TROUBLESHOOTING	11-16
COMPRESSOR AND ELECTRIC COMPONENTS	11
PTC AND OLP.....	12
OTHER ELECTRICAL COMPONENTS	13
SERVICE DIAGNOSIS CHART.....	14
REFRIGERATION CYCLE	15-16
OPERATION PRINCIPLE & REPAIR METHOD OF ICEMAKER	17-20
DESCRIPTION OF FUNCTION & CIRCUIT OF MICOM	21-41
EXPLODED VIEW & REPLACEMENT PARTS LIST	42-51

SAFETY PRECAUTIONS

Please read the following instructions before servicing your refrigerator.

1. Check the refrigerator for current leakage.
2. To prevent electric shock, unplug before servicing.
3. Always check line voltage and amperage.
4. Use standard electrical components.
5. Don't touch metal products in the freezer with wet hands. This may cause frostbite.
6. Prevent water from spilling onto electric elements or the machine parts.
7. Before tilting the refrigerator, remove all materials from on or in the refrigerator.
8. When servicing the evaporator, wear gloves to prevent injuries from the sharp evaporator fins.
9. Service on the refrigerator should be performed by a qualified technician. Sealed system repair must be performed by a CFC certified technician.

1. SPECIFICATIONS

22 cu. Ft. (22.4 cu. Ft.)

ITEMS	SPECIFICATIONS
DOOR DESIGN	Side Rounded
DIMENSIONS	W(836)x D(870)x H(1754) mm W(32.91)x D(34.25)x H(69.06) in
NET WEIGHT	127.5 Kg 281.09 pounds
COOLING SYSTEM	Fan Cooling
TEMPERATURE CONTROL	Micom Control
DEFROSTING SYSTEM	Full Automatic Heater Defrost
DOOR FINISH	Embossed Metal, VCM, Stainless
HANDLE TYPE	Bar
INNER CASE	ABS Resin
INSULATION	Polyurethane Foam

ITEMS	SPECIFICATIONS	
VEGETABLE TRAY	Opaque Drawer Type	
COMPRESSOR	PTC Starting Type	
EVAPORATOR	Fin Tube Type	
CONDENSER	Wire Condenser	
REFRIGERANT	R-134a (115 g)	
LUBRICATING OIL	ISO10 (220 ml)	
DEFROSTING DEVICE	SHEATH HEATER	
LAMP	REFRIGERATOR	60 W (2EA)
	FREEZER	60 W (1EA)

2. PARTS IDENTIFICATION

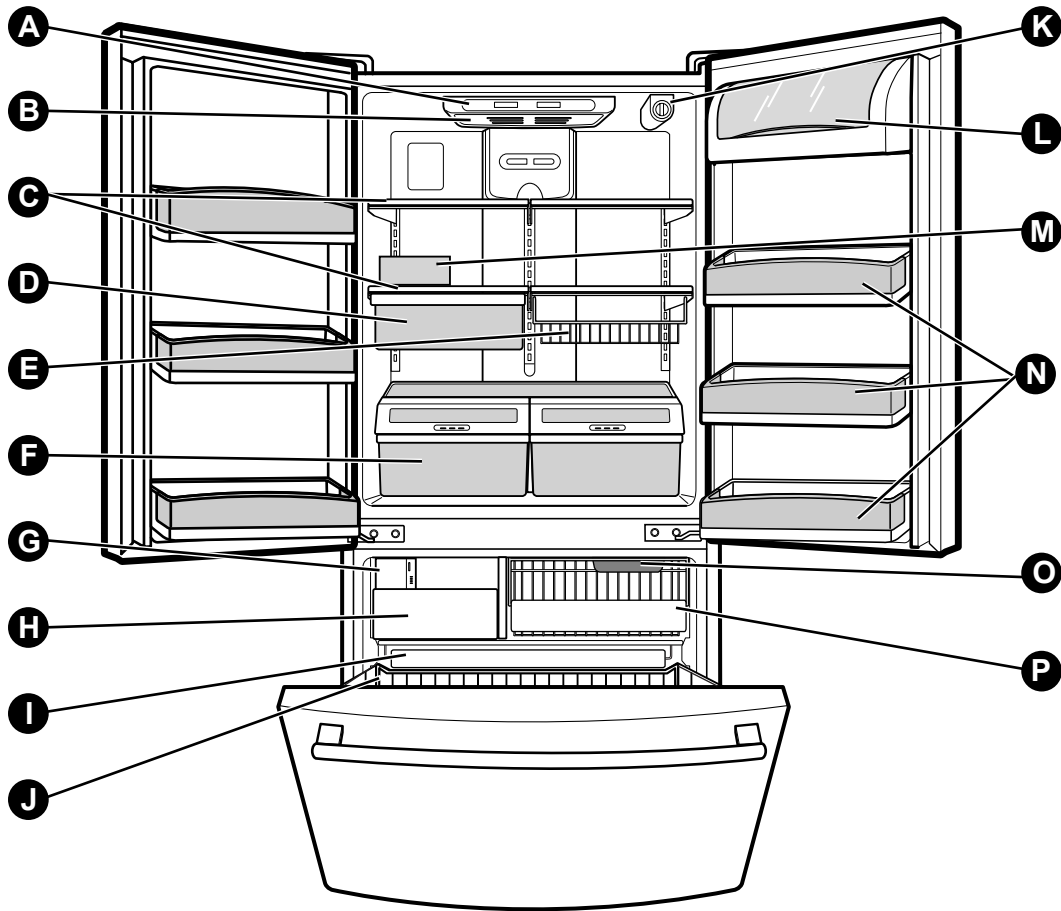

A Digital Sensor Control*

B Refrigerator Light

C Shelves

D Chef Fresh

E Can Dispenser

F Optibin Crisper
Keeps fruits and vegetable fresh and crisper

G Customcube Icemaker

H Ice Bin

I Full Width Wire Basket

J Wire Durabase

K Filter (inside)*

L Dairy Bin

M Egg Box

N Design-A-Door Bins

O Freezer Light

P Wire Basket

*On some models

3. DISASSEMBLY

3-1 DOOR

► Left Door

- Loosen the cover screw (1).
- Disconnect door switch wire (2).
- Loosen hinge bolts (3).
- Lift off the top hinge (4).
- Place the door on a non-scratching surface with the inside up.

► Right Door

- Loosen the cover screw (1).
- Disconnect door switch wire (2).
- Disconnect wire harness (5).
- Loosen hinge bolts (3).
- Loosen ground screw (6).
- Lift off the top hinge (4).
- Place the door on a non-scratching surface with the inside up.

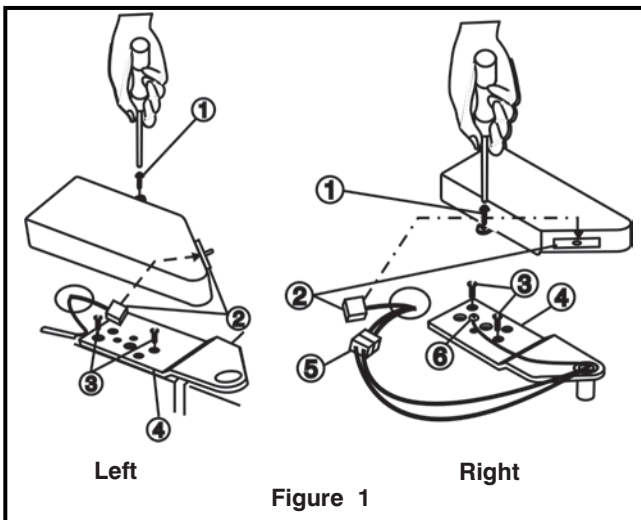

Figure 1

Door Gasket Removal

1. Remove door frame cover

Starting at top of cover and working down, snap cover out and away from door.

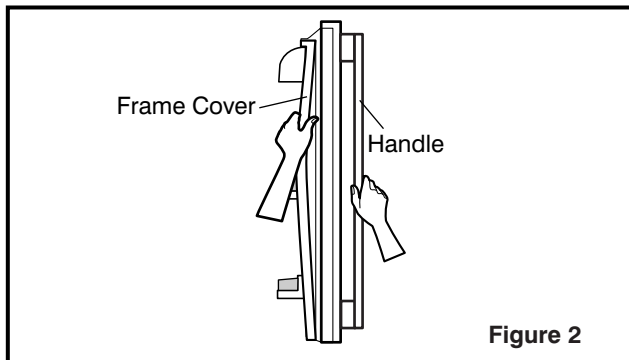

Figure 2

2. Remove gasket bracket clips

There are two clips on each door. Start bracket removal near one of the middle clips.

- 1) Pull gasket back to expose gasket bracket clip and door frame.
- 2) Insert a flat tip screwdriver into seam between gasket bracket and door frame and pry back until clips snap out.
- 3) Continue prying back along seam until all clips snap out.

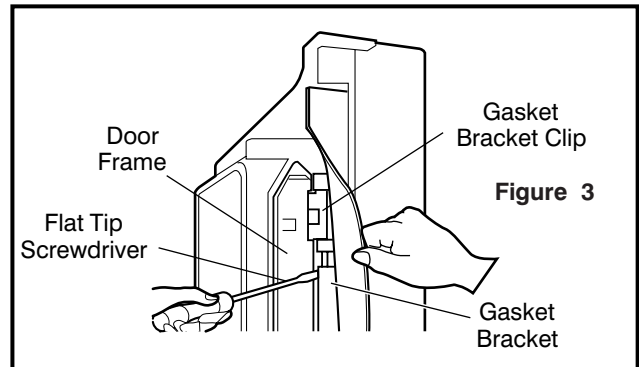

Figure 3

3. Remove gasket

Pull gasket free from gasket channel on the three remaining sides of door.

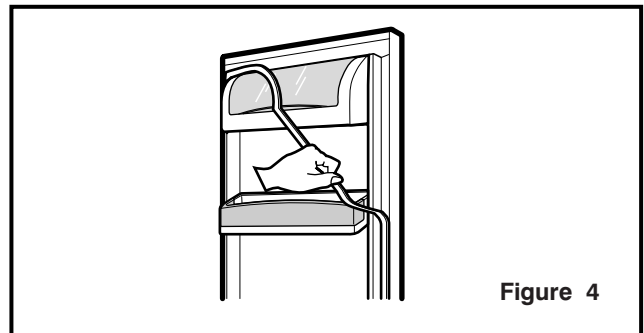

Figure 4

Door Gasket Replacement

1. Insert gasket bracket clips

- 1) Insert gasket bracket edge beneath door frame edge.
- 2) Turn upper gasket bracket spring so that both spring ends are in the door channel.
- 3) Push in clip until you hear it snap securely into place.

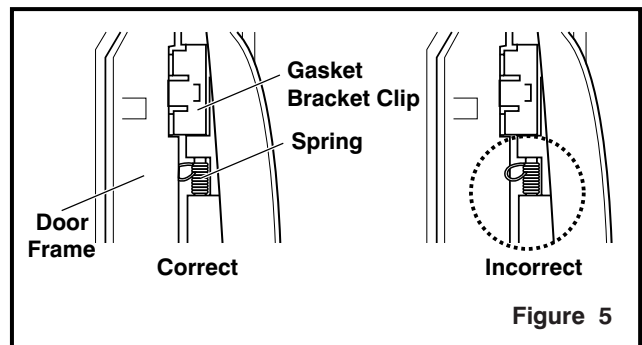

Figure 5

- 4) Push in remaining two clips until you hear each snap securely into place.

Note: Make sure that no part of gasket bracket edge protrudes from beneath door frame edge.

2. Insert gasket into channel

1) Snap gasket assembly into the door bracket.

<Inserting the Gasket Assembly into the Bracket Door>

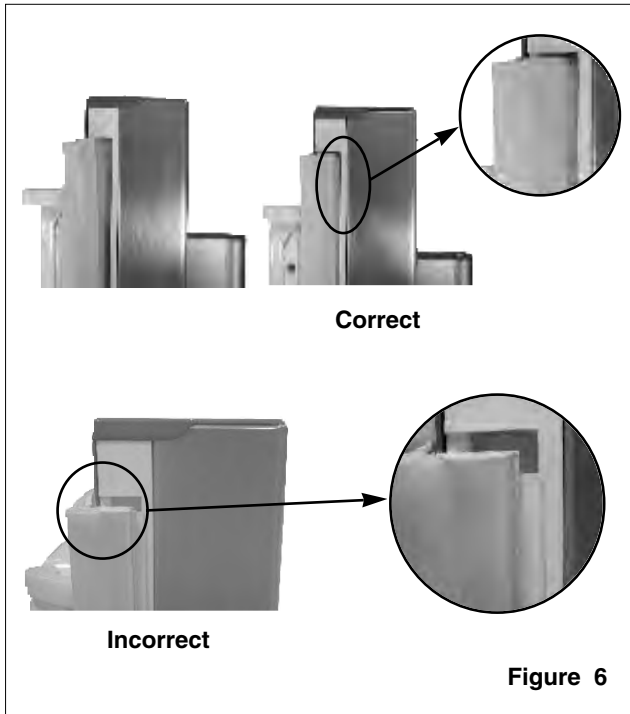

Figure 6

2) Press gasket into channels on the three remaining sides of door.

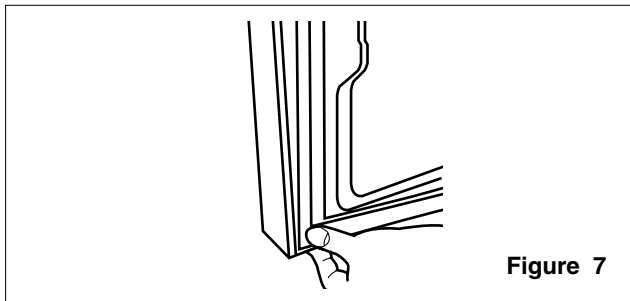

Figure 7

3. Replace door frame cover

Starting at top of cover and working down, snap cover back into door.

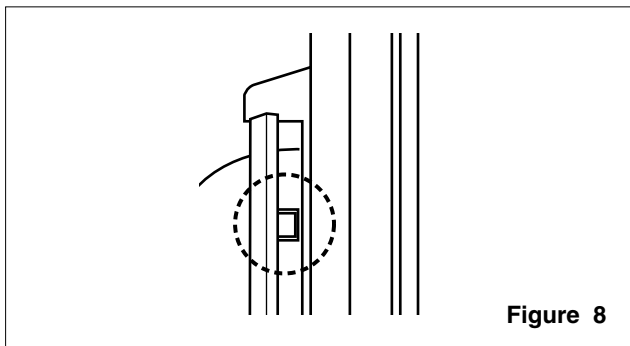

Figure 8

3-2 DOOR ALIGNMENT

If the space between your doors is uneven, follow the instructions below to align the doors:

1. With one hand, lift up the door you want to raise at middle hinge.
2. With other hand, use pliers to insert snap ring as shown.
3. Insert additional snap rings until the doors are aligned. (Three snap rings are provided with unit.)

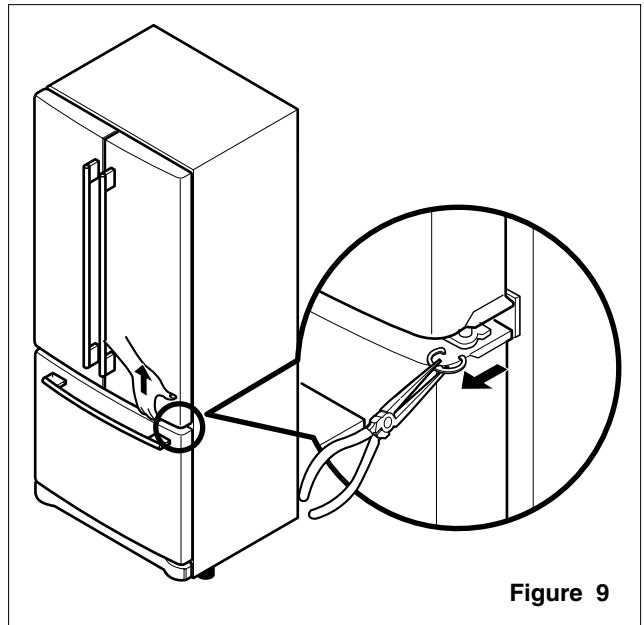

Figure 9

3-3 FAN AND FAN MOTOR

1. Remove the freezer shelf. (If your refrigerator has an icemaker, remove the icemaker first)
2. Remove the plastic guide for slides on left side by unscrewing phillips head screws.
3. Remove the grille by removing one screw and pulling the grille forward.
4. Remove the Fan Motor assembly by loosening 2 screws and disassembling the shroud.
5. Pull out the fan and separate the Fan Motor and Bracket.

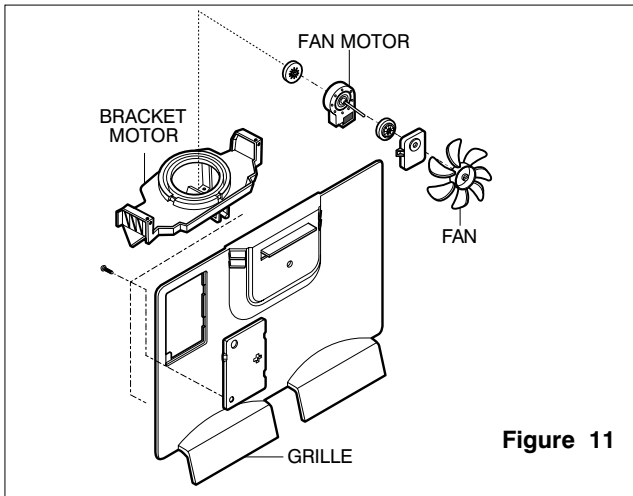

Figure 11

3-4 DEFROST CONTROL ASSEMBLY

Defrost Control assembly consists of Defrost Sensor and FUSE-M.

The Defrost Sensor works to defrost automatically. It is attached to the metal side of the Evaporator and senses its temperature. At 72°C, it turns the Defrost Heater off.

Fuse-M is a safety device for preventing over-heating of the Heater when defrosting.

1. Pull out the grille assembly. (Figure 12)
2. Separate the connector with the Defrost Control assembly and replace the Defrost Control assembly after cutting the Tie Wrap. (Figure 13)

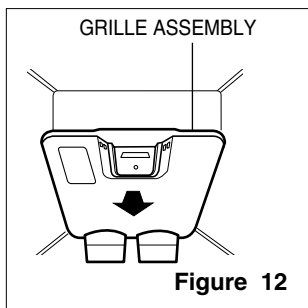

Figure 12

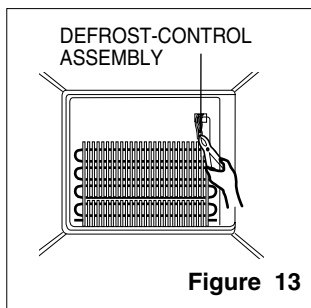

Figure 13

3-5 LAMP

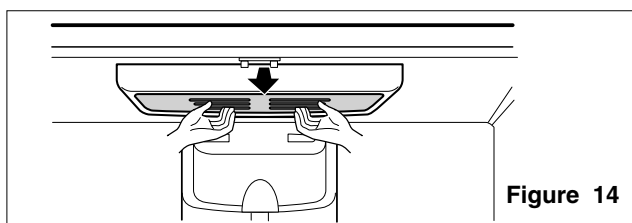

Figure 14

3-5-1 Refrigerator Compartment Lamp

1. Unplug the power cord from the outlet.
2. Remove refrigerator shelves.
3. Release the hooks on both ends of the lamp shield and pull the shield downward to remove it.
4. Turn the lamp counterclockwise.
5. Assembly is the reverse of disassembly. Replacement bulb must be the same specification as the original (Max. 60 W2EA).

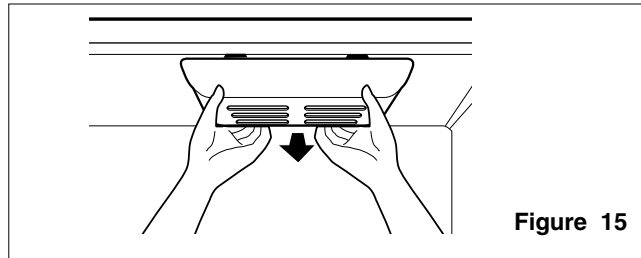

Figure 15

3-5-2 Freezer Compartment Lamp

1. Unplug refrigerator or disconnect power.
2. Reach behind light shield to remove bulb.
3. Replace bulb with a 60-watt appliance bulb.
4. Plug in refrigerator or reconnect power.

3-6 CONTROL BOX-REFRIGERATOR

1. First, remove all shelves in the refrigerator, then remove the Refrigerator control Box by loosening 2 screws.

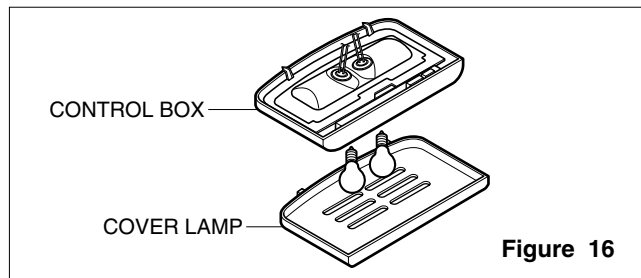

Figure 16

2. Remove the Refrigerator Control Box by pulling it downward.
3. Disconnect the lead wire on the right position and separate the lamp sockets.

3-7 MULTI DUCT

1. Remove the upper and lower Caps by using a flat screwdriver, and remove 2 screws. (Figure 17)
2. Disconnect the lead wire on the bottom position.

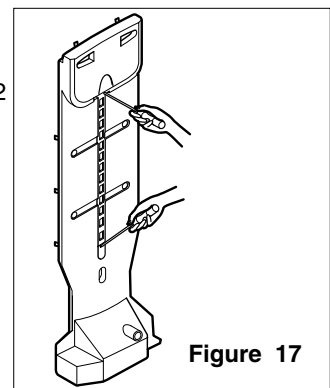

Figure 17

4. ADJUSTMENT

4-1 COMPRESSOR

4-1-1 Role

The compressor intakes low temperature and low pressure gas from the evaporator of the refrigerator and compresses this gas to high-temperature and high-pressure gas. It then delivers the gas to the condenser.

4-1-2 Composition

The compressor includes overload protection. The PTC starter and OLP (overload protector) are attached to the outside of the compressor. Since the compressor is manufactured to tolerances of 1 micron and is hermetically sealed in a dust and moisture-free environment, use extreme caution when repairing it.

4-1-3 Note for Usage

- (1) Be careful not to allow over-voltage and over-current.
- (2) If compressor is dropped or handled carelessly, poor operation and noise may result.
- (3) Use proper electric components appropriate to the Particular Compressor in your product.
- (4) Keep Compressor dry.
If the Compressor gets wet (in the rain or a damp environment) and rust forms in the pin of the Hermetic Terminal, poor operation and contact may result.
- (5) When replacing the Compressor, be careful that dust, humidity, and soldering flux don't contaminate the inside of the compressor. Contamination in the cylinder may cause noise, improper operation or even cause it to lock up.

4-2 PTC-STARTER

4-2-1 Composition of PTC-Starter

- (1) PTC (Positive Temperature Coefficient) is a no-contact semiconductor starting device which uses ceramic material consisting of BaTiO₃.
- (2) The higher the temperature is, the higher the resistance value. These features are used as a starting device for the Motor.

4-2-2 Role of PTC-Starter

- (1) The PTC is attached to the Sealed Compressor and is used for starting the Motor.
- (2) The compressor is a single-phase induction motor. During the starting operation, the PTC allows current flow to both the start winding and main winding.

4-2-3 PTC-Applied Circuit Diagram

● Starting Method for the Motor

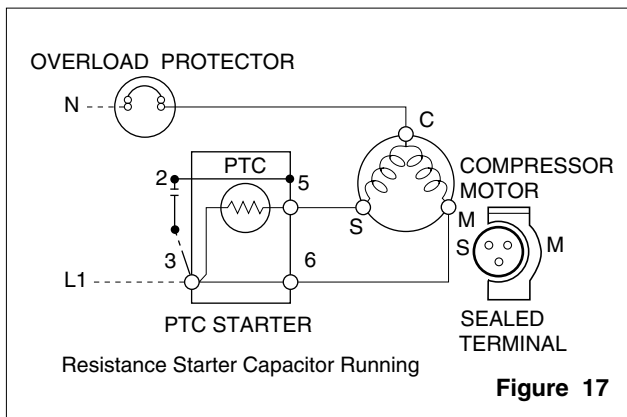

4-2-4 Motor Restarting and PTC Cooling

- (1) It requires approximately 5 minutes for the pressure to equalize before the compressor can restart.
- (2) The PTC device generates heat during operation. Therefore, it must be allowed to cool before the compressor can restart.

4-2-5 Relation of PTC-Starter and OLP

- (1) If the compressor attempts to restart before the PTC device is cooled, the PTC device will allow current to flow only to the main winding.
- (2) The OLP will open because of the over current condition. This same process will continue (3 to 5 times) when the compressor attempts to restart until the PTC device has cooled. The correct OLP must be properly attached to prevent damage to the compressor.

Parts may appear physically identical but could have different electrical ratings. Replace parts by part number and model number. Using an incorrect part could result in damage to the product, fire, injury, or possibly death.

4-2-6 Note for Using the PTC-Starter

- (1) Be careful not to allow over-voltage and over-current.
- (2) Do not drop or handle carelessly.
- (3) Keep away from any liquid.
If liquid such as oil or water enters the PTC, PTC materials may fail due to breakdown of their insulating capabilities.
- (4) If the exterior of the PTC is damaged, the resistance value may be altered. This can cause damage to the compressor and result in a no-start or hard-to-start condition.
- (5) Always use the PTC designed for the compressor and make sure it is properly attached to the compressor. Parts may appear physically identical but could have different electrical ratings. Replace parts by part number and model number. Using an incorrect part could result in damage to the product, fire, injury, or possibly death.

4-3 OLP (OVERLOAD PROTECTOR)

4-3-1 Definition of OLP

- (1) OLP (OVERLOAD PROTECTOR) is attached to the Compressor and protects the Motor by opening the circuit to the Motor if the temperature rises and activating the bimetal spring in the OLP.
- (2) When high current flows to the Compressor motor, the Bimetal works by heating the heater inside the OLP, and the OLP protects the Motor by cutting off the current flowing to the Compressor Motor.

4-3-2 Role of the OLP

- (1) The OLP is attached to the Sealed Compressor used for the Refrigerator. It prevents the Motor Coil from being started in the Compressor.
- (2) For normal operation of the OLP, do not turn the Adjust Screw of the OLP in any way.

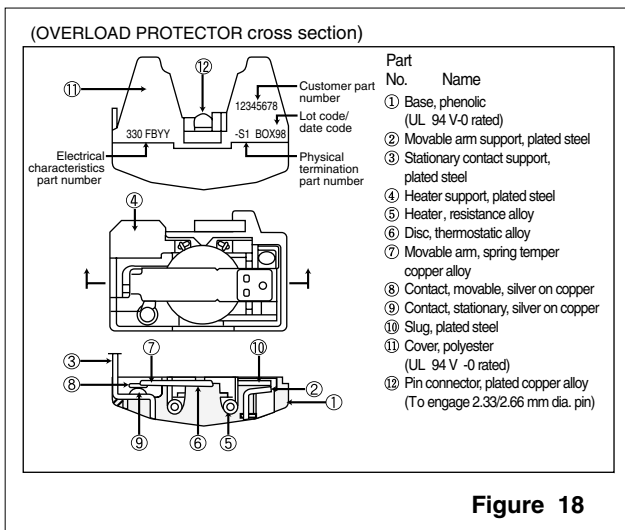
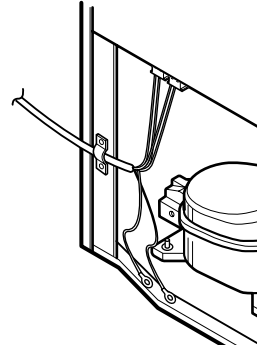
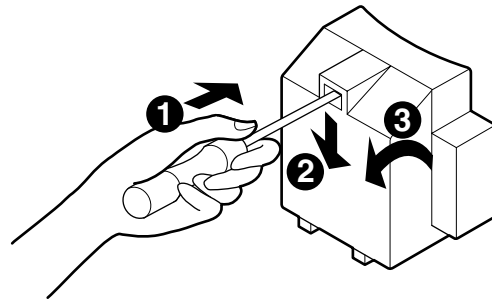

Figure 18

4-4 TO REMOVE THE COVER PTC



- 1) Remove the Cover Back M/C.
- (2) Disconnect two housing upper side of comp connected in.
- (3) Loosen two screws on comp base.



- (4) Use a L-shaped flap tool to pry off the cover.
- (5) Assembly in reverse order of disassembly.

5. CIRCUIT DIAGRAM



LG Electronics CIRCUIT DIAGRAM

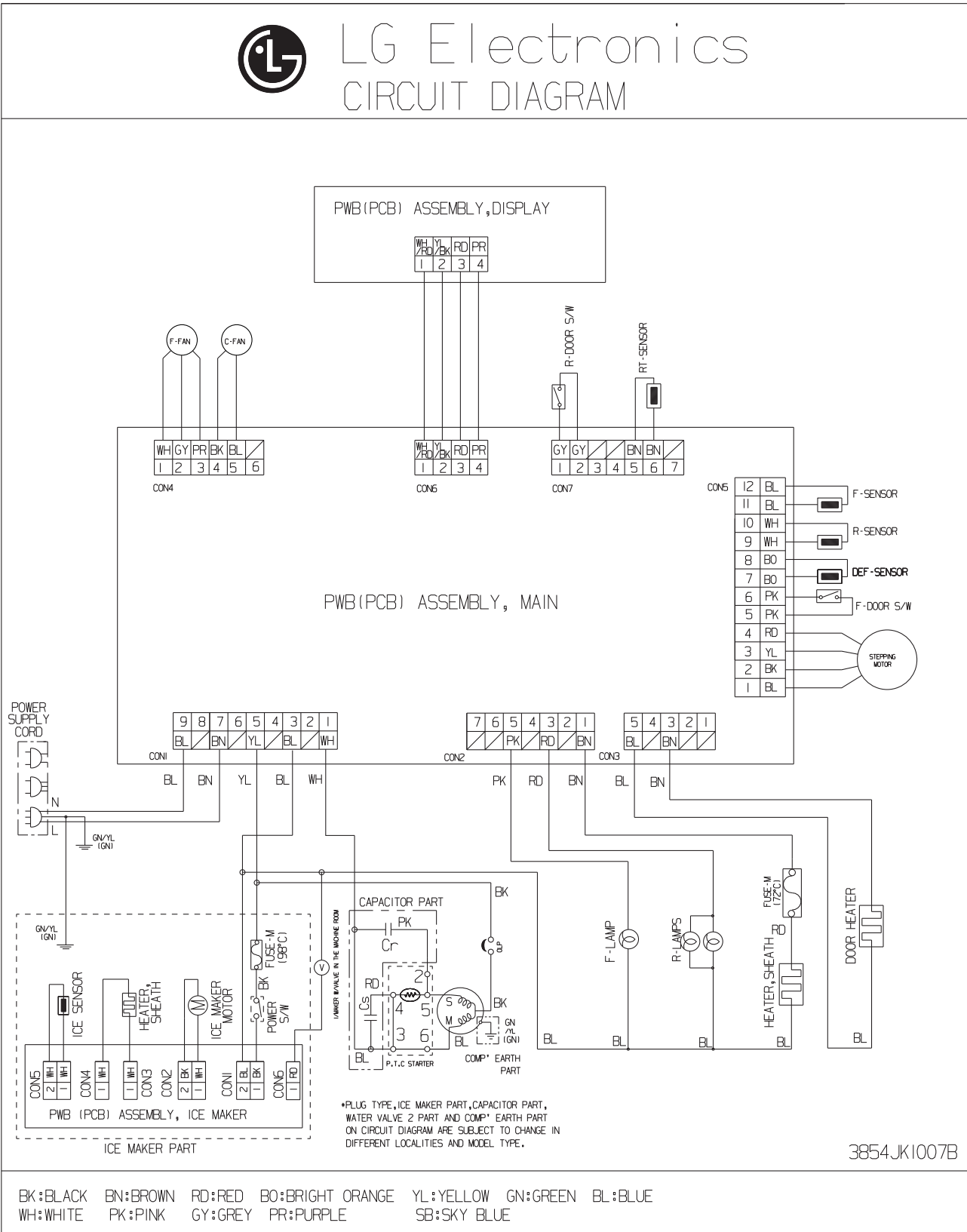

6. TROUBLESHOOTING

6-1 COMPRESSOR AND ELECTRIC COMPONENTS

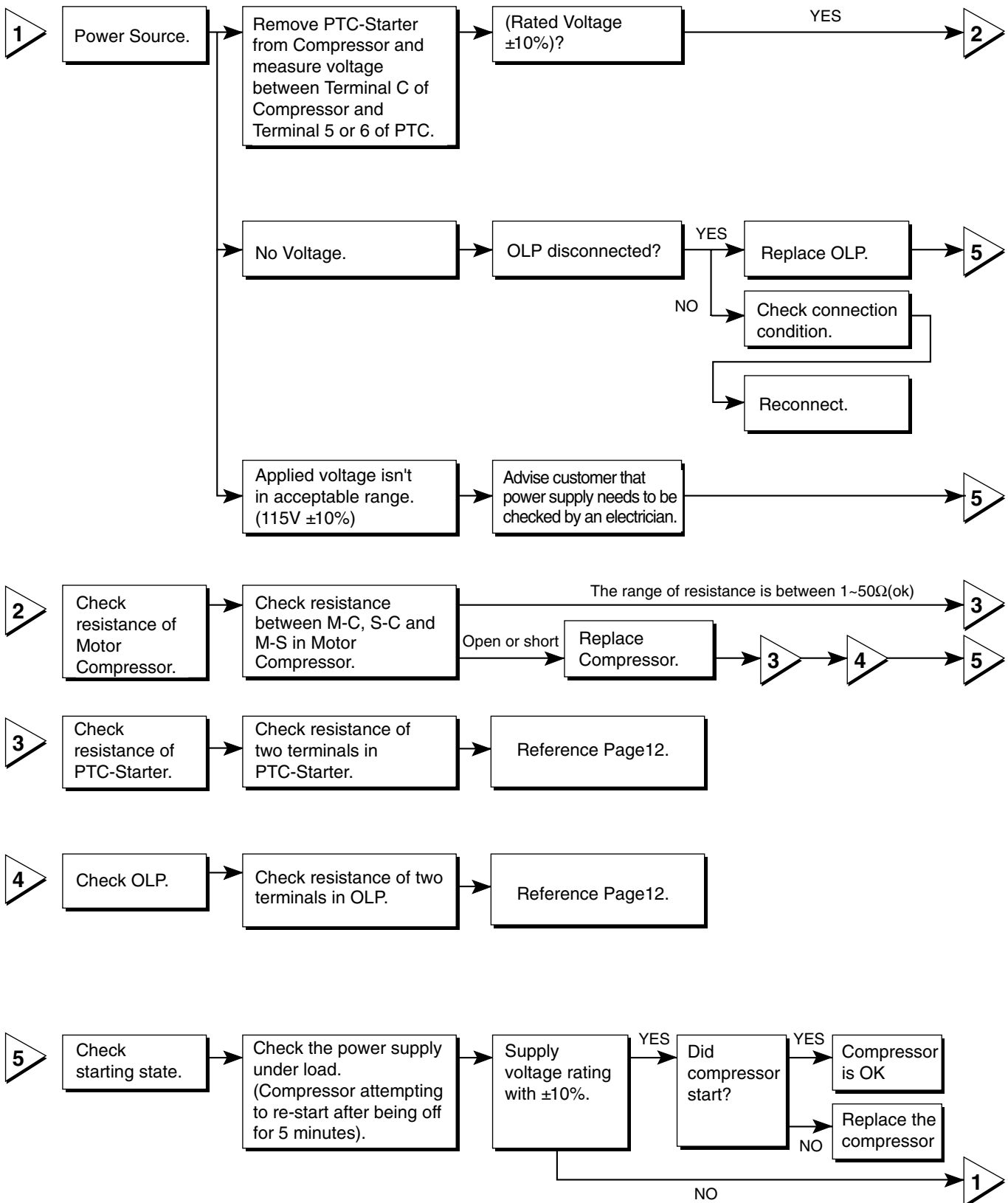

6-2 PTC AND OLP

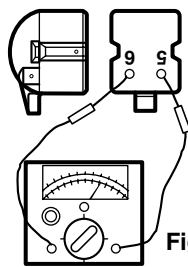
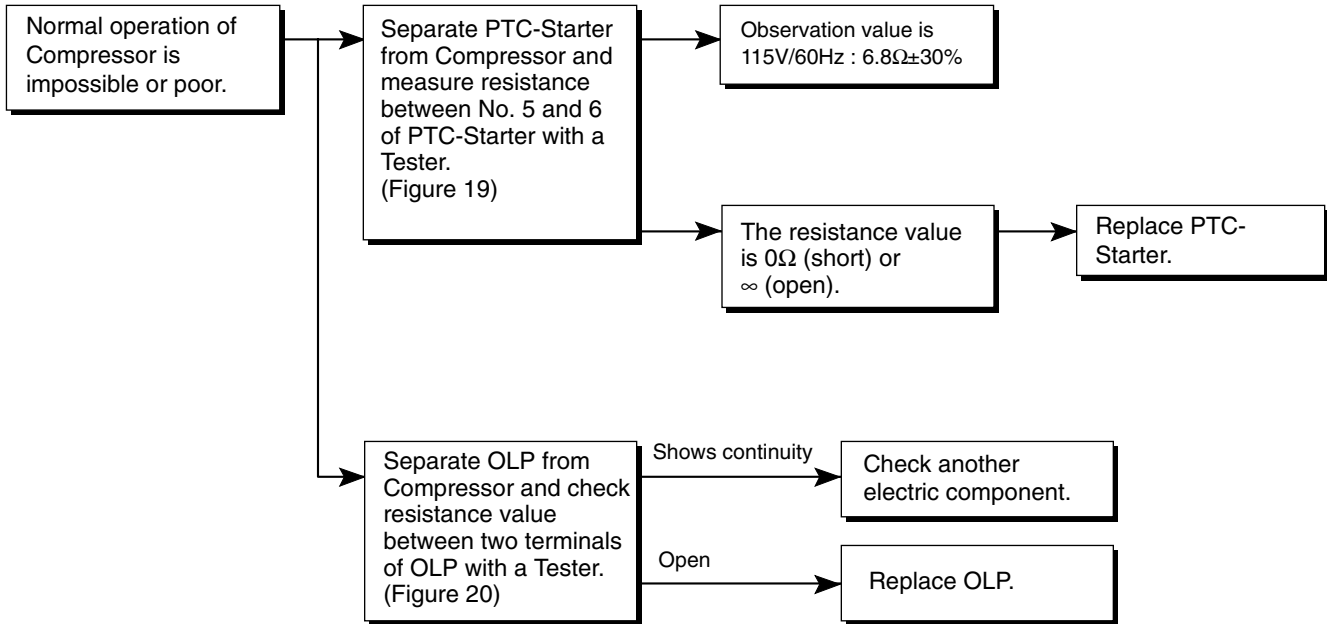

Figure 19

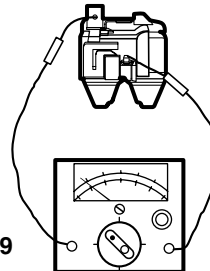
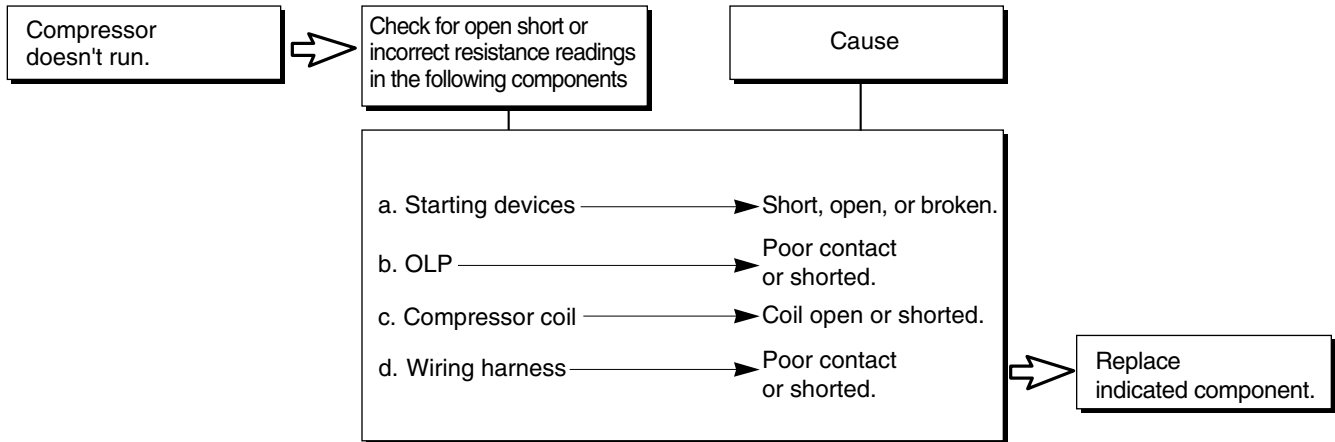

Figure 20

6-3 OTHER ELECTRICAL COMPONENTS

▼ Not cooling at all



▼ Poor cooling performance

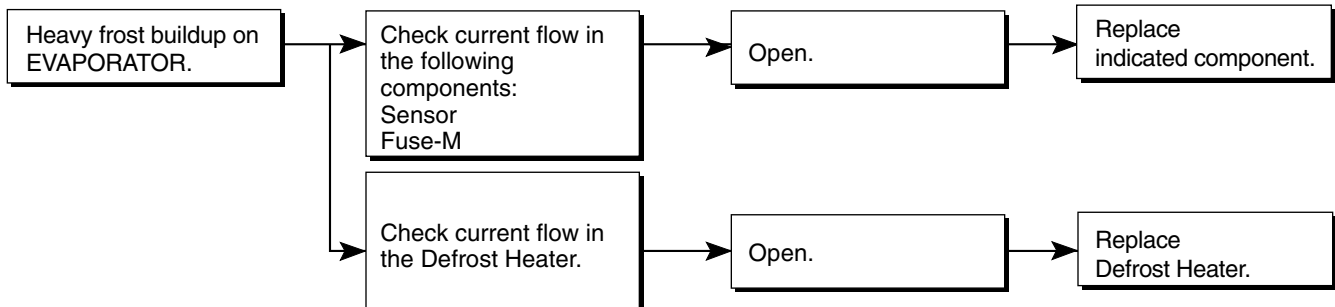
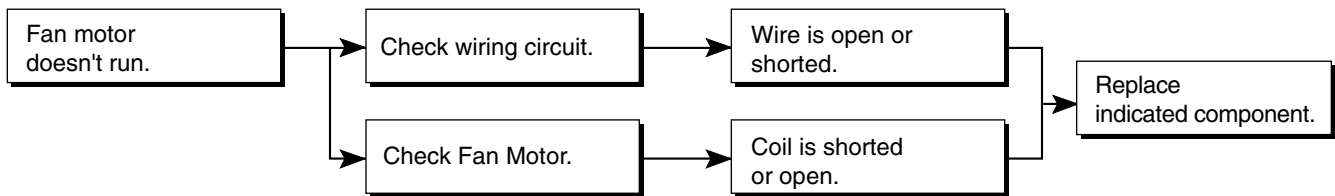
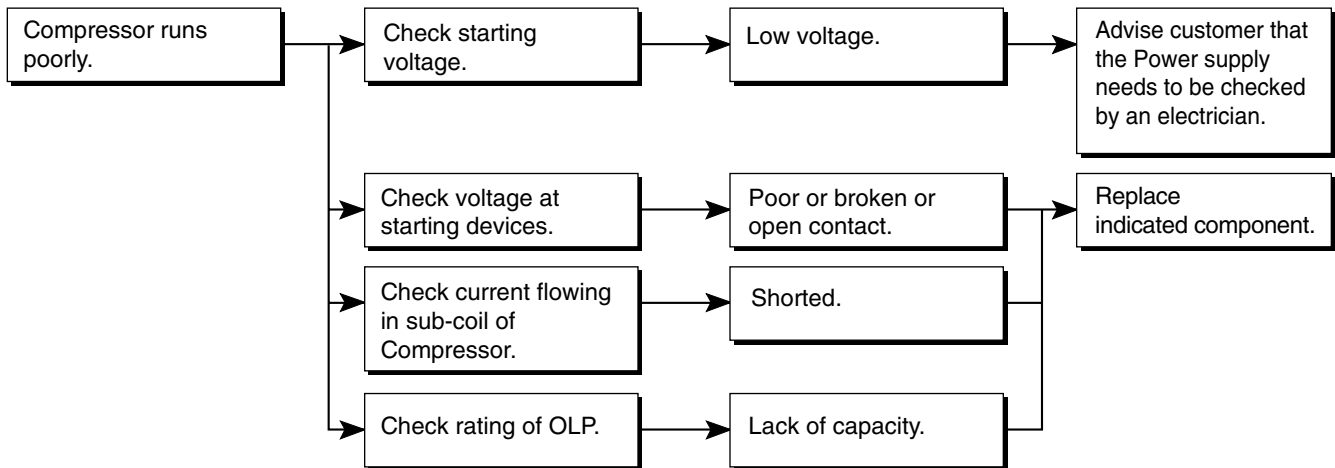

6-4 SERVICE DIAGNOSIS CHART

COMPLAINT	POINTS TO BE CHECKED	REMEDY
No Cooling.	<ul style="list-style-type: none"> Is the power cord unplugged from the outlet? Check if the power switch is set to OFF. Check if the fuse of the power switch is shorted. Measure the voltage of the power outlet. 	<ul style="list-style-type: none"> Plug into the outlet. Set the switch to ON. Replace the fuse. If the voltage is low, correct the wiring.
Cools poorly.	<ul style="list-style-type: none"> Check if the unit is placed too close to the wall. Check if the unit is placed too close to the stove, gas cooker, or in direct sunlight. Is the ambient temperature too high or the room door closed? Check if food put in the refrigerator is hot. Did you open the door of the unit too often or check if the door is sealed properly? Check if the Control is set to Warm position. 	<ul style="list-style-type: none"> Place the unit about 4 inches (10 cm) from the wall. Place the unit away from these heat sources. Lower the ambient temperature. Put in foods after they have cooled down. Don't open the door too often and close it firmly. Set the control to Recommended position.
Food in the Refrigerator is frozen.	<ul style="list-style-type: none"> Is food placed in the cooling air outlet? Check if the control is set to colder position. Is the ambient temperature below 5°C? 	<ul style="list-style-type: none"> Place foods in the high-temperature section. (front part) Set the control to Recommended position. Set the control to Warm position.
Condensation or ice forms inside the unit.	<ul style="list-style-type: none"> Is liquid food sealed? Check if food put in the refrigerator is hot. Did you open the door of the unit too often or check if the door is sealed properly? 	<ul style="list-style-type: none"> Seal liquid foods with wrap. Put in foods after they have cooled down. Don't open the door too often and close it firmly.
Condensation forms in the Exterior Case.	<ul style="list-style-type: none"> Check if the ambient temperature and humidity of the surrounding air are high. Is there a gap in the door gasket? 	<ul style="list-style-type: none"> Wipe moisture with a dry cloth. It will disappear in low temperature and humidity. Fill up the gap.
There is abnormal noise.	<ul style="list-style-type: none"> Is the unit positioned in a firm and even place? Are any unnecessary objects placed in the back side of the unit? Check if the Drip Tray is not firmly fixed. Check if the cover of the compressor enclosure in the lower front side is taken out. 	<ul style="list-style-type: none"> Adjust the Leveling Screw, and position the refrigerator in a firm place. Remove the objects. Fix the Drip Tray firmly in the original position. Place the cover in its original position.
Door does not close well.	<ul style="list-style-type: none"> Check if the door gasket is dirty with an item like juice. Is the refrigerator level? Is there too much food in the refrigerator? 	<ul style="list-style-type: none"> Clean the door gasket. Position in a firm place and level the Leveling Screw. Make sure food stored in shelves does not prevent the door from closing.
Ice and foods smell unpleasant.	<ul style="list-style-type: none"> Check if the inside of the unit is dirty. Are foods with a strong odor unwrapped? The unit smells of plastic. 	<ul style="list-style-type: none"> Clean the inside of the unit. Wrap foods that have a strong odor. New products smell of plastic, but this will go away after 1-2 weeks.

● Other possible problems:

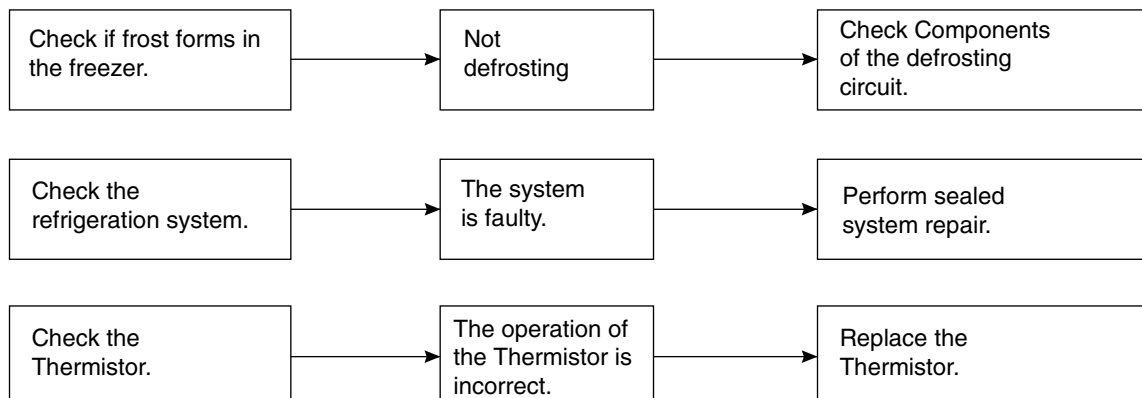

6-5 REFRIGERATION CYCLE

▼ Troubleshooting Chart

CAUSE		STATE OF THE UNIT	STATE OF THE EVAPORATOR	TEMPERATURE OF THE COMPRESSOR	REMARKS
LEAKAGE	PARTIAL LEAKAGE	Freezer compartment and Refrigerator don't cool normally.	Low flowing sound of Refrigerant is heard and frost forms in inlet only.	A little higher than ambient temperature.	<ul style="list-style-type: none"> Refrigerant level is low due to a leak. Normal cooling is possible by restoring the normal amount of refrigerant and repairing the leak.
	COMPLETE LEAKAGE	Freezer compartment and Refrigerator don't cool normally.	Flowing sound of refrigerant is not heard and frost isn't formed.	Equal to ambient temperature.	<ul style="list-style-type: none"> No discharging of Refrigerant. Normal cooling is possible by restoring the normal amount of refrigerant and repairing the leak.
CLOGGED BY DUST	PARTIAL CLOG	Freezer compartment and Refrigerator don't cool normally.	Flowing sound of refrigerant is heard and frost forms in inlet only.	A little higher than ambient temperature.	<ul style="list-style-type: none"> Normal discharging of the refrigerant. The capillary tube is faulty.
	WHOLE CLOG	Freezer compartment and Refrigerator don't cool.	Flowing sound of refrigerant is not heard and frost isn't formed.	Equal to ambient temperature.	<ul style="list-style-type: none"> Normal discharging of the Refrigerant.
MOISTURE CLOG		Cooling operation stops periodically.	Flowing sound of refrigerant is not heard and frost melts.	Lower than ambient temperature.	<ul style="list-style-type: none"> Cooling operation restarts when heating the inlet of the capillary tube.
DEFECTIVE COMPRESSION	COMP-RESSION	Freezer and Refrigerator don't cool.	Low flowing sound of refrigerant is heard and frost forms in inlet only.	A little higher than ambient temperature.	<ul style="list-style-type: none"> Low pressure at high side of compressor due to low refrigerant level.
	NO COMP-RESSION	No compressing operation.	Flowing sound of refrigerant is not heard and there is no frost.	Equal to ambient temperature.	<ul style="list-style-type: none"> No pressure in the high pressure part of the compressor.

6-5-1 SEALED SYSTEM DIAGNOSIS

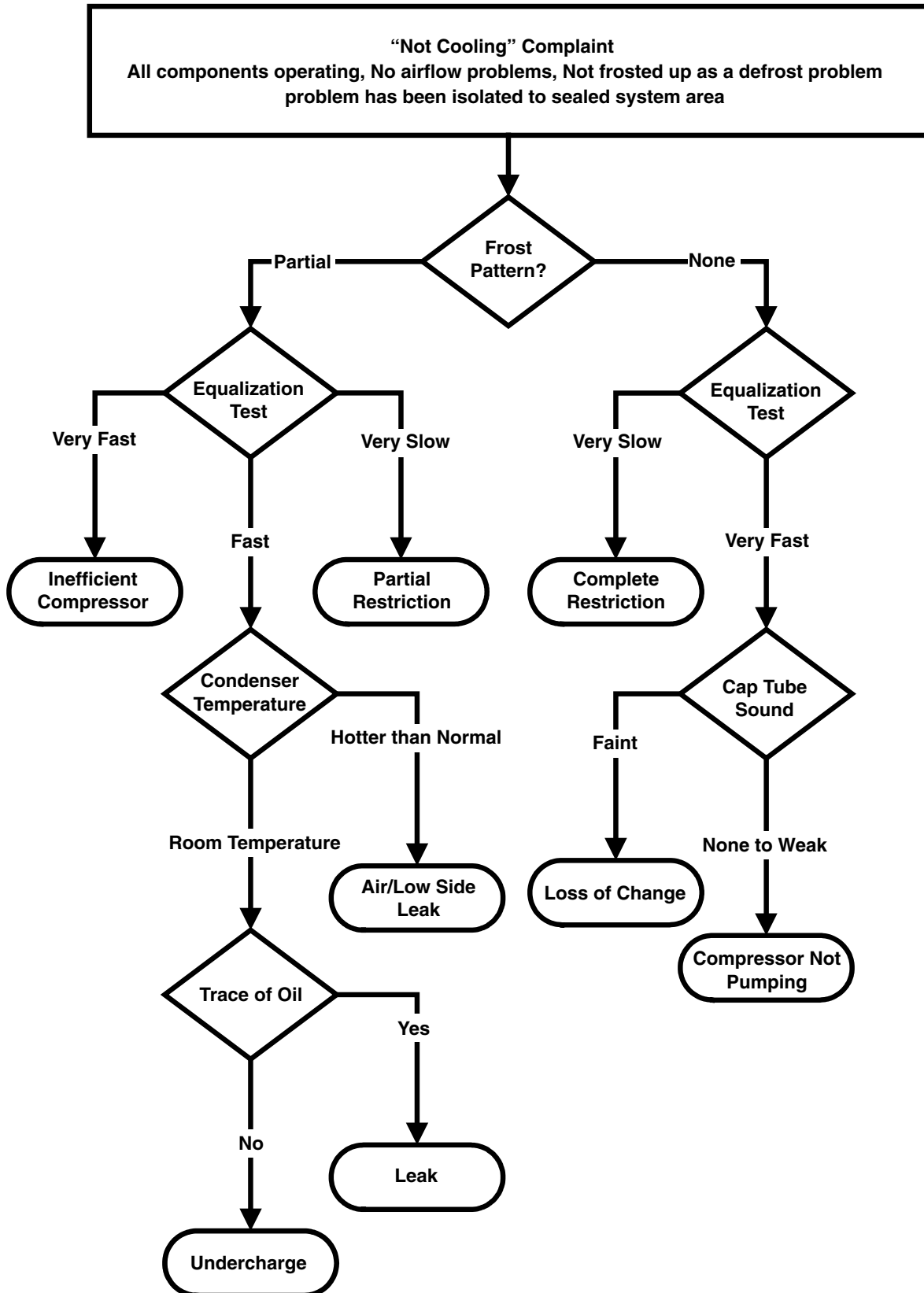

(The equalization test is trying to restart a compressor using a start kit after it has been operating.)

7. OPERATION PRINCIPLE AND REPAIR METHOD OF ICEMAKER

7-1 OPERATION PRINCIPLE

7-1-1 Operation Principle of IceMaker

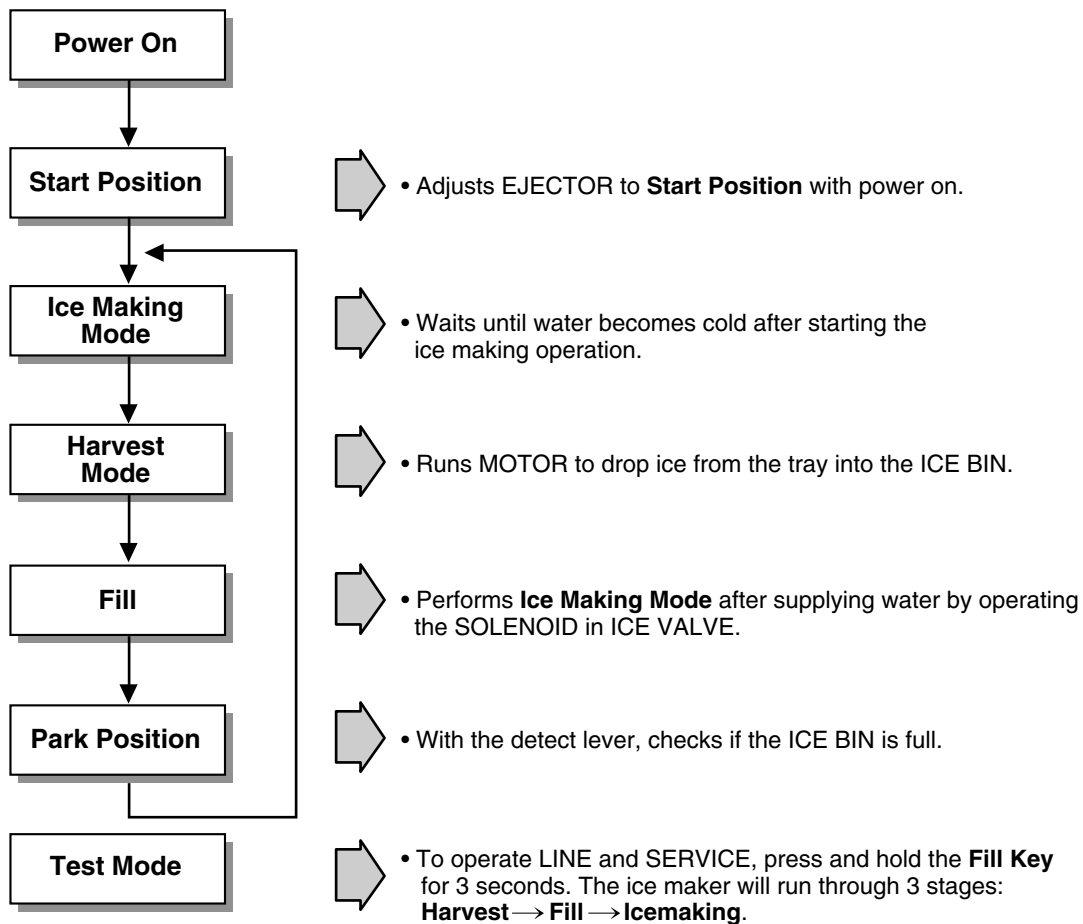

1. Turning the Icemaker stop switch off (O) stops the ice making function.
2. Setting the Icemaker switch to OFF and then turning it back on will reset the icemaker control.

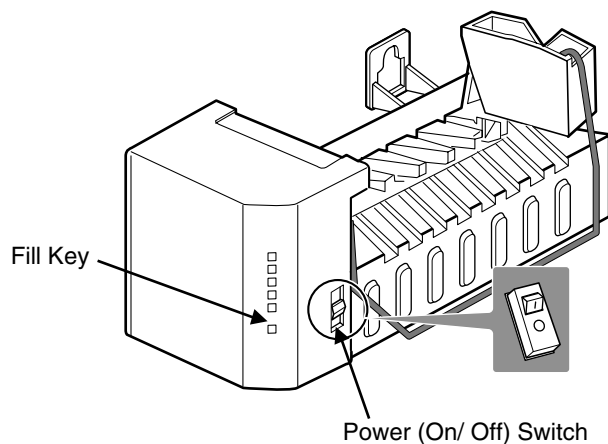

7-2 ICE MAKER FUNCTIONS

7-2-1 Start Position

1. After POWER OFF or Power Outage, check the EJECTOR's position with MICOM initialization to restart.
2. How to check if it is in place:
 - Check **HIGH/LOW** signals from HALL SENSOR in MICOM PIN.
3. Control Method to check if it is in place:
 - (1) EJECTOR is in place,
 - It is an initialized control, so the mode can be changed to ice making control.
 - (2) EJECTOR isn't in place:
 - A. If EJECTOR is back in place within 2 minutes with the motor on, it is being initialized. If not, go to Step B.
 - B. If EJECTOR is back in place within 18 minutes after the heater turns from ON to OFF, it is being initialized. If not, it is not functioning. Repeat Step B with Heater and Motor off.

7-2-2 Ice Making Mode

1. Ice Making refers to the freezing of supplied water in the ice trays. Complete freezing is assured by measuring the temperature of the Tray with Ice-Making SENSOR.
2. Ice Making starts after completion of the water fill operation.
3. The Ice Making function is completed when the sensor reaches -7°C , 60 to 240 minutes after starting.
4. If the temperature sensor is defective, the ice-making function will be completed in 4 hours.

NOTE : After Icemaker Power is ON, the Icemaker heater will be on for test for 9 sec.

7-2-3 Harvest Mode

1. Harvest (Ice removing) refers to the operation of dropping cubes into the ice bin from the tray when ice-making has completed.
2. Harvest mode:
 - (1) The Heater is ON for 30 seconds, then the motor starts.
 - (2) After performing Step 1 (the Heater is turned OFF), the Ejector will be back in place within 18 minutes. (Hall SENSOR sign = 0V). Ice removal is then complete. Then the Ice Maker cycles to the Fill Mode. The water supply fails to start, it is not functioning. Put the Heater and Motor in the off position. Restart every 2 hours. (Refer to fig.1)

NOTE : If the motor malfunctions and starts before the detect lever rises, MICOM regards the Ice-Removing phase as completed. Water then starts flowing. To prevent this, MICOM doesn't switch to water-supply mode, but restarts the ice-removing mode. If this happens 3 times, the motor is malfunctioning and you should stop the loads (Heater, Motor). Then restart the Ice-Removing mode every 2 hours. (See Step 2 above.)

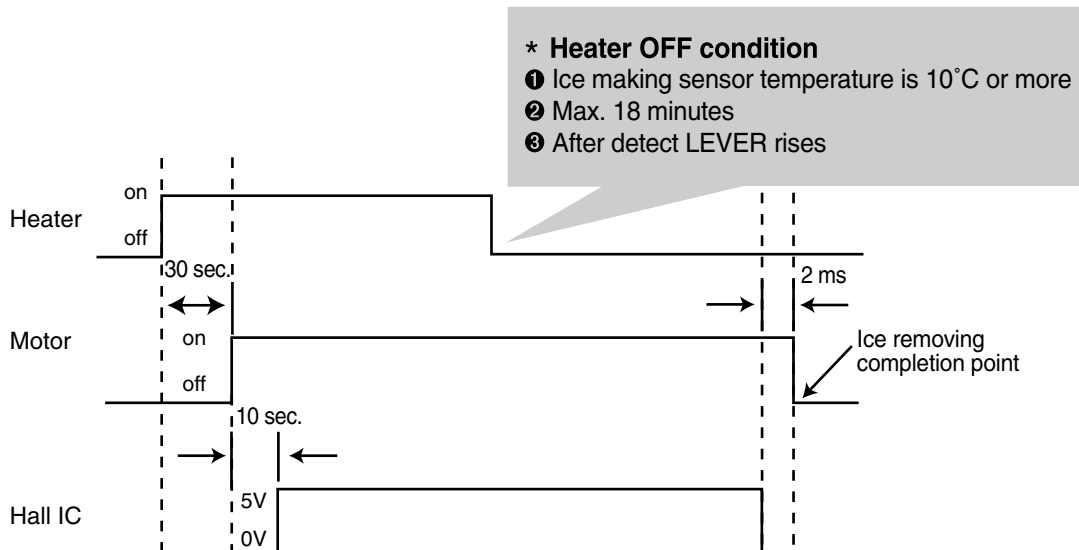





<fig1. Harvest mode Process>

7-2-4 Fill / Park Position

1. Once a normal harvest mode has been completed, the water solenoid will be activated.
2. The amount of water is adjusted by pressing the Fill Key repeatedly. This changes the time allowed for fill as illustrated in the table below.





<Water supply amount TABLE>

STAGE	TIME TO SUPPLY	INDICATIONS	REMARKS
1	6 sec.		<p>The water amount will vary depending on the water control Switch setting, as well as the water pressure of the connected water line.</p>
2	6.5 sec.		
3	7 sec.		
4	7.5 sec.		
5	8 sec.		

7-2-5 Function TEST



1. This is a compulsory operation for TEST, SVC, cleaning, etc. It is operated by pressing and holding the Fill Key for 3 seconds.
2. The test works only in the Ice Making Mode. It cannot be entered from the Harvest or Fill mode. (If there is an ERROR, it can only be checked in the TEST mode.)
3. **Caution!** If the test is performed before water in the Maker is frozen, the Ejector will pass through the water. When the Fill mode begins (Stage 4), unless the water supply has been shut off, added water will overflow into the ice bin. If the control doesn't operate normally in the TEST mode, check and repair as needed.
4. After water is supplied, the normal CYCLE is followed: **ice making** → **Harvest** → **Fill** → **Park Position**.
5. Five seconds after Stage 5 is completed, the Ice Maker returns to MICOM control. The time needed to supply water resets to the pre- test setting.

<Diagnosis TABLE>

STAGE	ITEMS	INDICATOR	REMARKS
1	HEATER		Five seconds after heater starts, heater will go off if temperature recorded by sensor is 10°C or lever is in up position.
2	MOTOR		Five seconds after heater starts, you can confirm that motor is moving.
3	HALL IC I (detection of position)		You can confirm Hall Ic detection of position.
4	VALVE		Two seconds after detection of initial position, you can confirm that valve is on.
5	HALL IC II (detection of full-filled Ice)		You can check whether hall is sensing Full ice condition. (If there is a full-filled error, the fifth LED is not on.)
6	Reset	Return to Status prior to TEST MODE	Five seconds after fifth stage is completed, the icemaker resets to initial status.

7-3 DEFECT DIAGNOSIS FUNCTION

7-3-1 ERROR CODES shown on Ice Maker water supply control panel

NO	DIVISION	INDICATOR	CONTENTS	REMARKS
1	Normal	Mark time to supply	None	Display switch operates properly
2	Ice-Making Sensor malfunction		Open or short-circuited wire	Make sure that the wire on each sensor is connected.
3	Ice Maker Kit malfunction		When ejector blades don't reach park position over 18 minutes after Harvest Mode starts.	Check HALL IC/MOTOR/HEATER/RELAY

ERROR indicators in table can be checked only in TEST mode.

8. DESCRIPTION OF FUNCTION & CIRCUIT OF MICOM

8-1 FUNCTION

8-1-1 Function

1. When the appliance is plugged in, it is set to 37°F for Refrigerator and 0°F for freezer.
You can adjust the Refrigerator and the Freezer control temperature by pressing the ADJUST button.
2. When the power is initially applied or restored after a power failure, it is automatically set to "37" & "0".

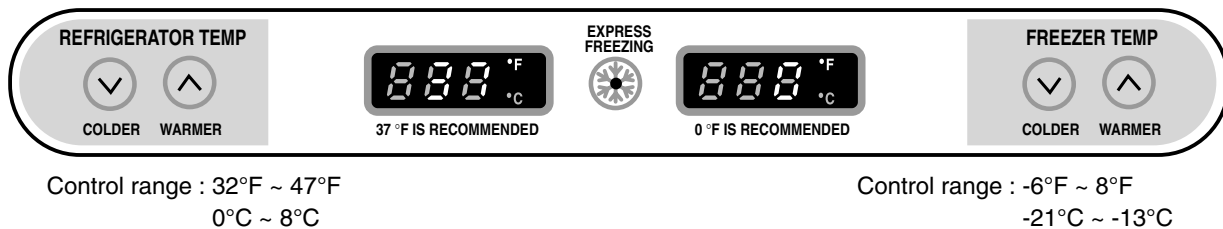

8-1-2 How to Toggle the Display between °F & °C

1. The display temperature mode can be changed from °F to °C or °C to °F by pressing and holding the COLDER FREEZER TEMP and the COLDER REFRIGERATOR TEMP keys at the same time for over one second.
2. The initial setting is °F. Whenever the mode is changed, the LED lights are changed.

8-1-3 Control of freezer fan motor

1. Freezer fan motor has high and standard RPMs.
2. High RPM is used when electricity is first on, for express freezing, and when refrigerator is overloaded.
Standard RPM is used for normal usage.
3. Fan motor stops when refrigerator or freezer door opens.

8-1-4 EXPRESS FREEZING

1. The purpose of this function is to intensify the cooling speed of freezer and to increase the amount of ice.
2. Whenever selection switch is pressed, selection/release, the LED will turn ON or OFF.
3. If there is a power outage and the refrigerator is powered on again, EXPRESS FREEZING will be canceled.
4. To activate this function you need to press the Express Freezing key and the LED will turn ON. This function will remain activated for 24 hrs. The first three hours the compressor and Freezer Fan will be ON. The next 21 hours the freezer will be controlled at the lowest temperature. After 24 hours or if the Express Freezing key is pressed again, the freezer will return to its previous temperature.
5. During the first 3 hours:
 - (1) Compressor and freezer fan(HIGH RPM) run continuously.
 - (2) If a defrost cycle begins during the first 90 minutes of Express Freezing, the Express Freeze cycle will complete its cycle after defrosting has ended. If the defrost cycle begins when Express Freeze has run for more than 90 minutes, Express Freeze will run for two hours after the defrost is completed.
 - (3) If EXPRESS FREEZING is pressed during defrost, EXPRESS FREEZING LED is on but this function will start seven minutes after defrost is completed and it shall operate for three hours.
 - (4) If EXPRESS FREEZING is selected within seven minutes after compressor has stopped, the compressor (compressor delays seven minutes) shall start after the balance of the delay time.
 - (5) The fan motor in the freezer compartment rotates at high speed during EXPRESS FREEZING.
6. For the rest of 21 hours, the freezer will be controlled at the lowest temperature.

8-1-5. REFRIGERATOR LAMP AUTO OFF

1. To protect the risk of lamp heat, when Refrigerator door opens for 7 min., refrigerator lamp is auto off.

8-1-6 Alarm for Open Door

1. This feature sounds a buzzer when the freezer or refrigerator door is not closed within 1 minute after it is opened.
2. One minute after the door is opened, the buzzer sounds three times each for 1/2 seconds. These tones repeat every 30 seconds.
3. The alarm is cancelled when the freezer or the refrigerator is closed while the buzzer sounds.

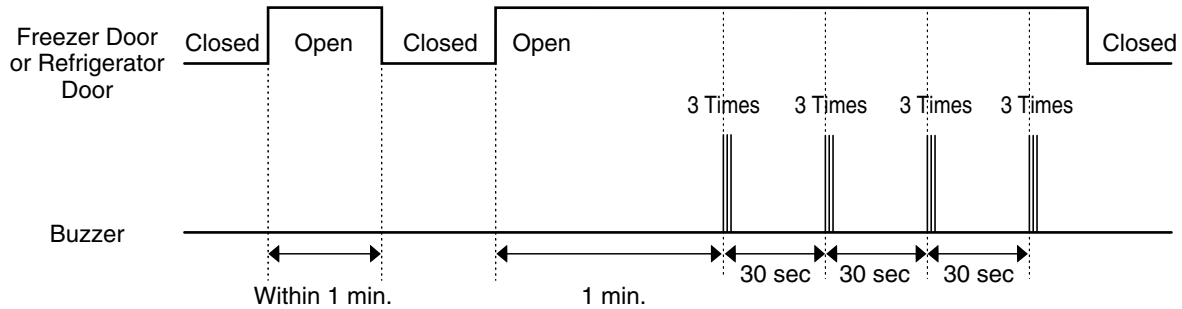

8-1-7 Buzzer Sound

When the button on the front Display is pushed, a Ding~ Dong~ sound is produced.

8-1-8 Defrosting (removing frost)

1. Defrosting starts each time the COMPRESSOR running time reaches 7 hours.
2. For initial power on or for restoring power, defrosting starts when the compressor running time reaches 4 hours.
3. Defrosting stops if the sensor temperature reaches 8°C or more. If the sensor doesn't reach 8°C in 2 hours, the defrost mode is malfunctioning.
4. Defrosting won't function if its sensor is defective (wires are cut or short circuited)

8-1-9 Electrical Parts Are Turned On Sequentially

Electrical parts such as COMP, defrosting heater, freezer FAN, etc. are turned on in the following order to prevent noise and parts damage. Several parts are started at the same time at initial power on and are turned off together when TEST is completed.

OPERATING		ORDERS				
Initial power on	Temperature of Defrosting Sensor is 45°C or more (when unit is newly purchased or when moved)	POWER ON	in 0.5 sec →	COMP ON	in 0.5 sec →	Freezer FAN ON
	Temperature of defrosting sensor is lower than 45°C (when power cuts, SERVICE)	POWER ON	in 0.5 sec →	Defrosting heater ON	in 10 sec →	Defrost heater OFF
		in 0.5 sec →	COMP ON	in 0.5 sec →	Freezer FAN ON	
	Reset to normal operation from TEST MODE	Total load OFF	in 7 min →	COMP ON	in 0.5 sec →	Freezer FAN ON

8-1-10 Defect Diagnosis Function

1. Automatic diagnosis makes servicing the refrigerator easy.
2. When a defect occurs, the buttons will not operate; but the tones, such as ding, will sound.
3. When the defect CODE removes the sign, it returns to normal operation (RESET).
4. The defect CODE shows on the Refrigerator and Freezer Display.

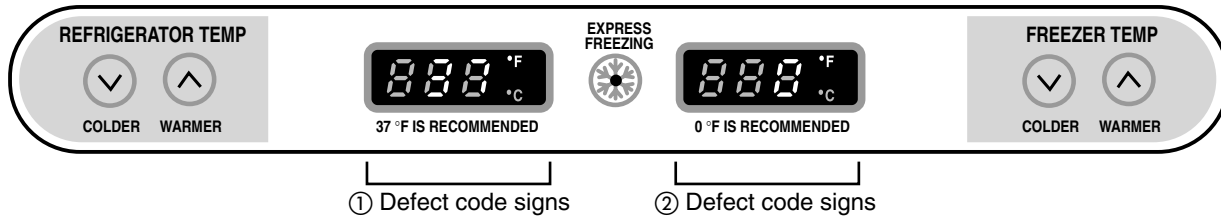

ERROR CODE on display panel

NO	ITEM	ERROR CODE		CONTENTS	REMARKS
		①	②		
1	Failure of freezer sensor	Er	F5	Cut or short circuit wire	Inspect Connecting wires on each sensor
2	Failure of Refrigerator sensor	Er	r5	Cut or short circuit wire	
3	Failure of defrost sensor	Er	d5	Cut or short circuit wire	
4	Failure of Room Temperature sensor	When display check mode: Er rt		Cut or short circuit wire	
5	Failure of defrost mode	Er	dH	When defrost sensor doesn't reach 8°C within 2 hours after starting defrost.	Snapping of defrost heater or Temperature fuse, pull-out of connector (indicated minimum 2 hours after failure occurs)
6	Failure of BLDC Fan Motor at Freezing Compartment	Er	FF	If there is no fan motor signal for more than 65sec in operation fan motor	Poor motor, hooking to wires of fan, contact of structures to fan, snapping or short circuit of Lead wires

Note 1) Room Temperature Sensor is not indicated on the failure indicating part but indicated in checking Display. (When pressing for more than the warmer key of Refrigerator Temp. and the warmer key of Freezer Temp for more than 1 second).

* LED check function: If simultaneously pressing the warmer key of Refrigerator Temp and the warmer key of Freezer Temp for a second, all display LED graphics on. If releasing the button, the LED graphics displays the previous status.

8-1-11 TEST Mode

1. The Test mode allows checking the PCB and the function of the product as well as finding out the defective part in case of an error.
2. The test mode is operated by pressing two buttons at Display panel.
3. While in the test mode, the function control button is not recognized, but the recognition tone (beep~) sounds.
4. After exiting the test mode, be sure to reset by unplugging and then plugging in the appliance.
5. If an error, such as a sensor failure, is detected while in the test mode, the test mode is cleared and the error code is displayed.
6. While an error code is displayed, the test mode will not be activated.

MODE	MANIPULATION	CONTENTS	REMARKS
TEST1	Push Express Freezing Key and COLDER KEY of Freezer Temp. at the Same time for 3 seconds. OR Push TEST S/W (on the main Board) Once.	1) Continuous operation of the COMPRESSOR and the Freezer fan 2) Stepping DAMPER OPEN 3) Defrosting HEATER OFF 4) DISPLAY LED all ON	
TEST2	Push Express Freezing Key and COLDER KEY of Freezer Temp. at the Same time for 3 seconds. In TEST MODE 1 OR Push TEST S/W Once in TEST MODE 1	1) Continuous operation of the COMPRESSOR and the Freezer fan 2) Stepping DAMPER CLOSE 3) Defrosting HEATER OFF 4) DISPLAY LED ahows no. 2	
TEST3	Push Express Freezing Key and COLDER KEY of Freezer Temp. at the Same time for 3 seconds. In TEST MODE 2 OR Push TEST S/W Once in TEST MODE 2	1) COMPRESSOR and the Freezer fan OFF 2) Stepping DAMPER CLOSE 3) Defrosting HEATER ON 4) DISPLAY LED ahows no. 3	Reset if the Temperature of the Defrosting sensor is 8°C or more.
Reset	Push Express Freezing Key and COLDER KEY of Freezer Temp. at the Same time for 3 seconds. In TEST MODE 3 OR Push TEST S/W Once in TEST MODE 3	Reset to the previously setting Before TEST MODE	The compressor will Start after a 7-minute Delay.

* Freezer Fan RPM Variable Check:

In case the freezer fan is in operation when the WARMER KEY in Refrigerator and Freezer Temp. Control are pressed for more than one second at the same time freezer fan RPM changes. (for example if high speed, to normal speed or if normal speed, to high speed for 30 seconds)
After 30 seconds, it turns to its original RPM.

* Demonstration (Display) MODE:

1. To enter this mode, raise either the Refrigerator or Freezer temperature to its highest setting. Then, press that Warmer Key and hold for about 5 seconds.
2. The LED panels will display OFF, to indicate that the Compressor, Circulating Fan, Damper, and Defrost Heater are not operating.
3. The Open Door Alarm and the Lamp Auto-Off feature will work normally and can be demonstrated.
4. To reset to normal operation, press and hold either Warmer Key for about 5 seconds.

8-2 PCB FUNCTION

8-2-1 Power Circuit

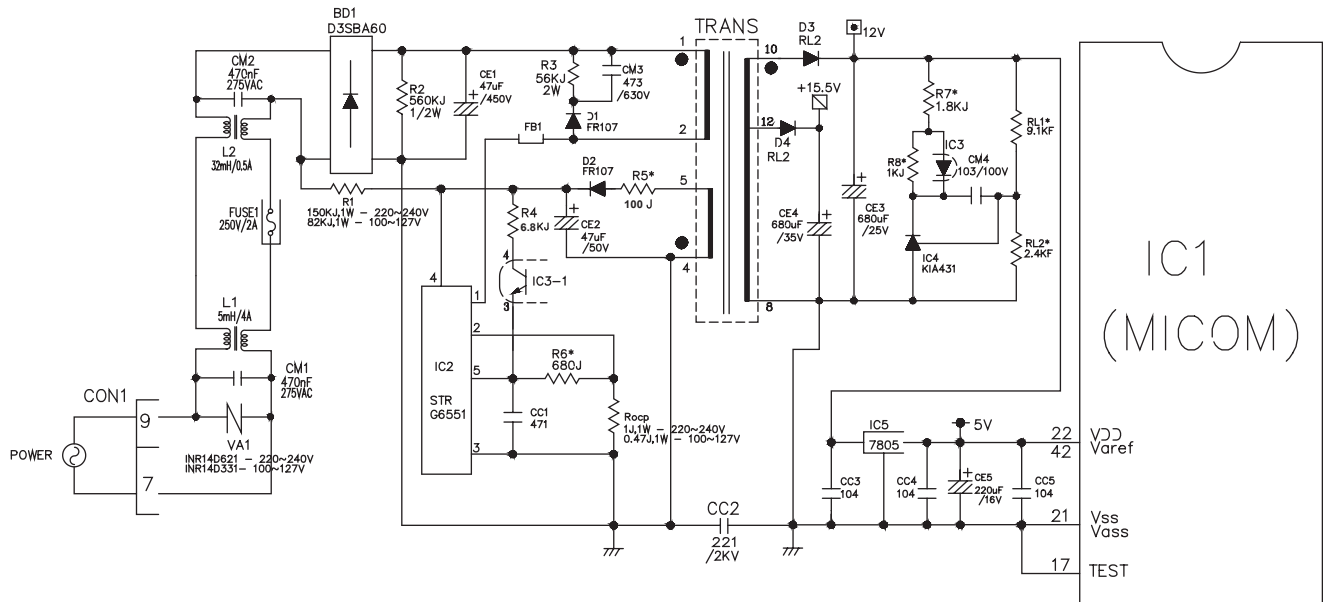

The secondary part of the TRANSFORMER is composed of the power supply for the display, the BLDC FAN Motor drive (15.5 V), the relay drive (12 Vdc) and the MICOM and IC (5 Vdc).

The voltage for each part is as follows:

PART	VA 1	CE 3	CE 4	CE 5
VOLTAGE	115 Vac	12 Vdc	15.5 Vdc	5 V

VA1 is a part for preventing over voltage and noise. When 385V or higher power is applied, the inside elements are short-circuited and broken, resulting in blowout of the fuse in order to protect the elements of the secondary part of the TRANSFORMER.

8-2-2 Oscillation Circuit

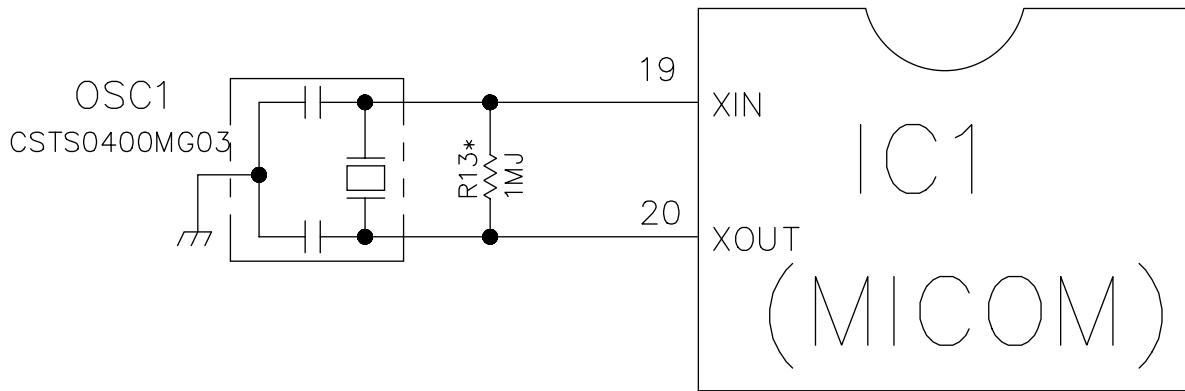

This circuit generates the base clock for calculating time and the synchro clock for transmitting data from and to the inside logic elements of the IC1 (MICOM). Be sure to use specified replacement parts, since calculating time by the IC1 may be changed. If changed, the OSC1 SPEC will not work.

8-2-3 Reset Circuit

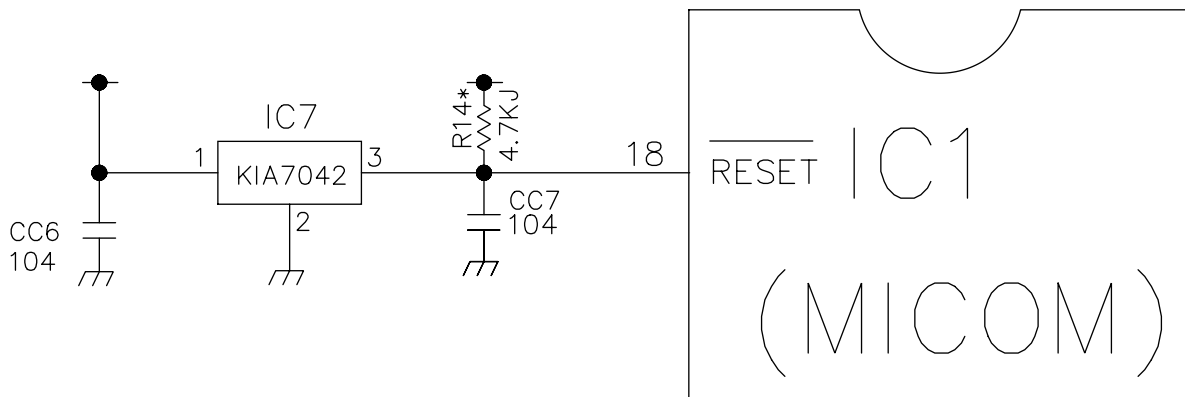

The RESET circuit allows all the functions to start at the initial conditions by initializing various parts, including the RAM inside the MICOM (IC1) when the power is initially supplied or the power supply to the MICOM is restored after a momentary power failure. For the initial 10ms of power supply, LOW voltage is applied to the MICOM RESET terminal. During a normal operation, 5V is applied to the RESET terminal. (If a malfunction occurs in the RESET IC, the MICOM will not operate.)

8-2-4 Load / Buzzer Drive & Open Door Detection Circuit

1. Load Drive Condition Check

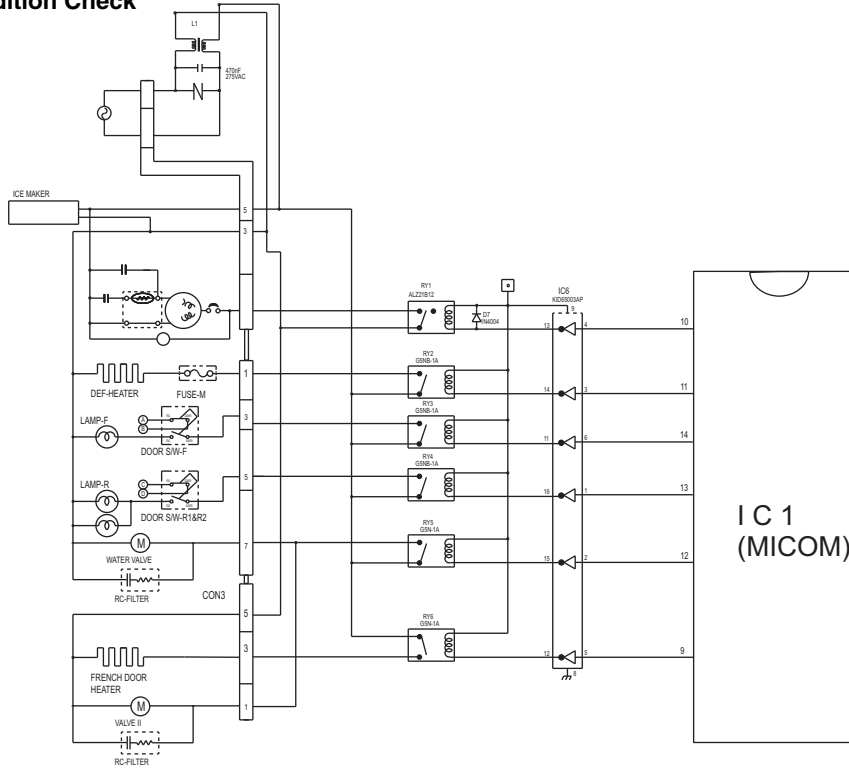

LOAD TYPE	COMP	DEFROSTING HEATER	LAMP	FRENCH DOOR HEATER 1, 2 / DEW HEATER	VALVE
Measurement Location (IC6)	NO.13	NO.14	NO.16	NO.12	NO.15
Condition	ON	1V or below			
	OFF	12V			

2. Motors driving circuit

2.1 Fan motor driving circuit (freezing compartment fan)

1. This circuit makes standby power 0 by cutting off power supplied to ISs inside of the fan motor in the fan motor OFF.
2. This is a circuit to perform a temporary change of speed for the fan motor and applies DC voltage up to 7.5V ~ 16V to motor.
3. This circuit prevents over-driving the fan motor by cutting off power applied to the fan motor in the lock of fan motor by sensing the operation RPM of the fan motor.

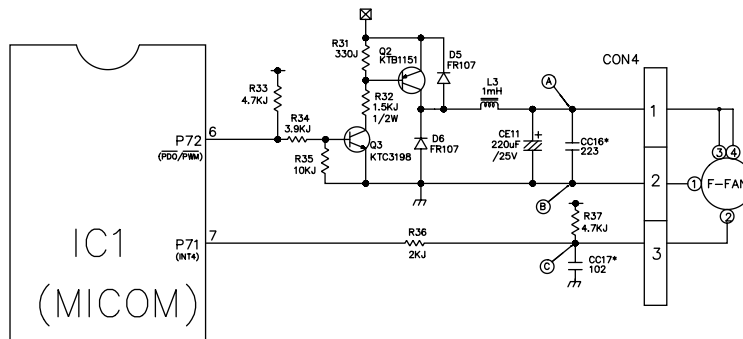

	Ⓐ part	Ⓑ part	Ⓒ part
MOTOR OFF	2V or less	0V	5V
MOTOR ON	13V~15V	0V	2V~3V

2.2 Cooling motor driving circuit (machine room)

1. This circuit makes standby power 0 by cutting off power supplied to ISs inside of the fan motor in the fan motor OFF
2. This circuit prevents over-driving the fan motor by cutting off power applied to the fan motor in the lock of fan motor by sensing the operation RPM of the fan motor.

	Ⓐ Part	Ⓑ part
MOTOR OFF	2V or less	0V
MOTOR ON	13V~15V	0V

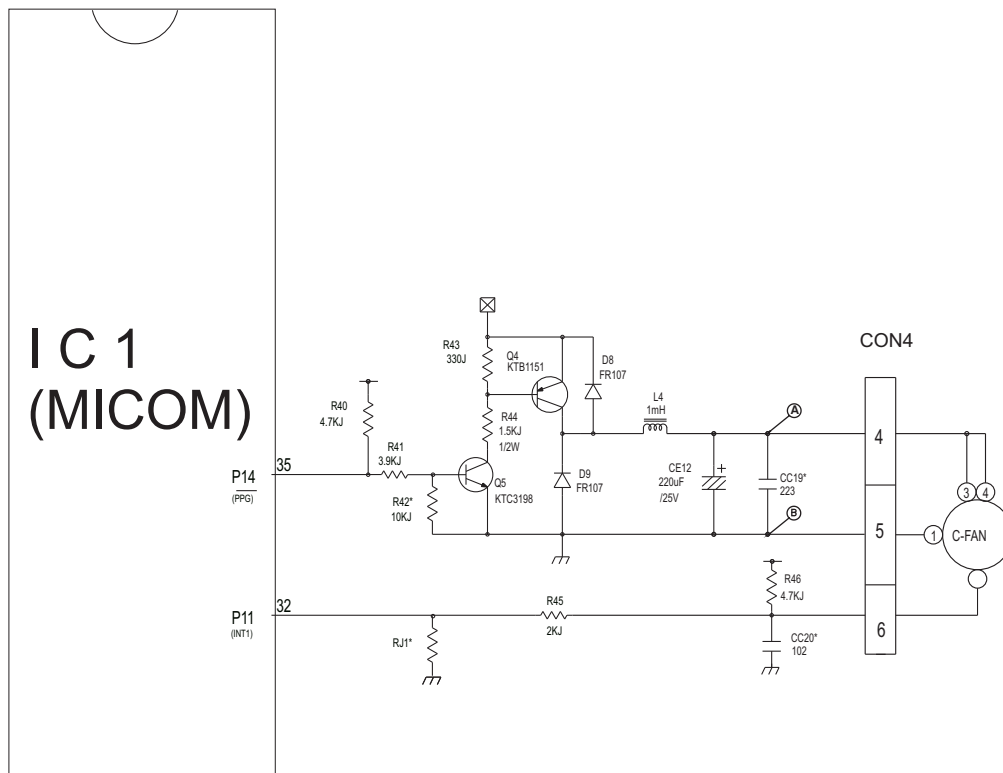

3. Open Door Detection Circuit Check

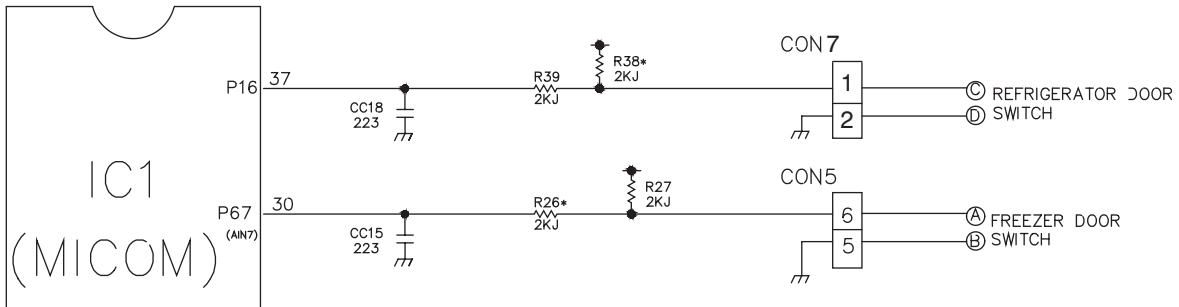

Measurement Location	(PIN NO.30 & PIN NO.37)
Closed	5 V
Open	0 V

8-2-5 Temperature Sensor Circuit

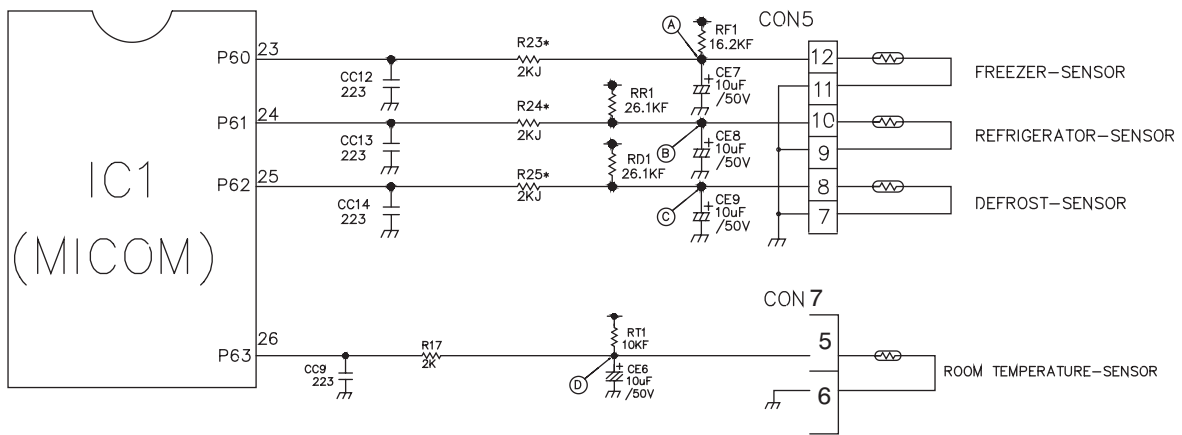

The upper CIRCUIT reads REFRIGERATOR temperature, FREEZER Temperature, and DEFROST-SENSOR temperature for defrosting and the indoor temperature for compensating for the surrounding temperature into MICOM.

OPENING or SHORT state of each TEMPERATURE SENSOR are as follows:

SENSOR	CHECK POINT	NORMAL (-30°C ~ 50°C)	SHORT-CIRCUITED	OPEN
Freezer Sensor	POINT (A) Voltage	0.5 V ~ 4.5 V	0 V	5 V
Refrigerator Sensor	POINT (B) Voltage			
Defrosting Sensor	POINT (C) Voltage			
Room Temperature sensor	POINT (D) Voltage			

8-2-6 Refrigeration Compartment Stepping Motor Damper Circuit

* The circuit shown below is the damper circuit to regulate the refrigerator temperature.

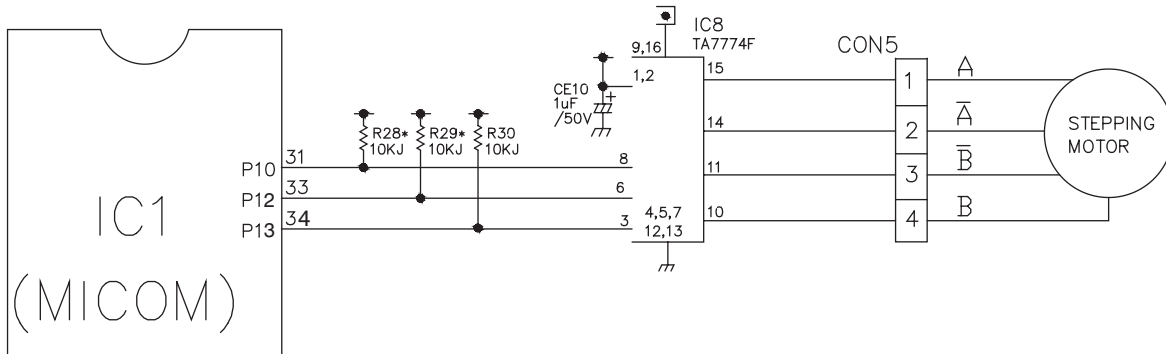

8-2-7 Dispenser Input

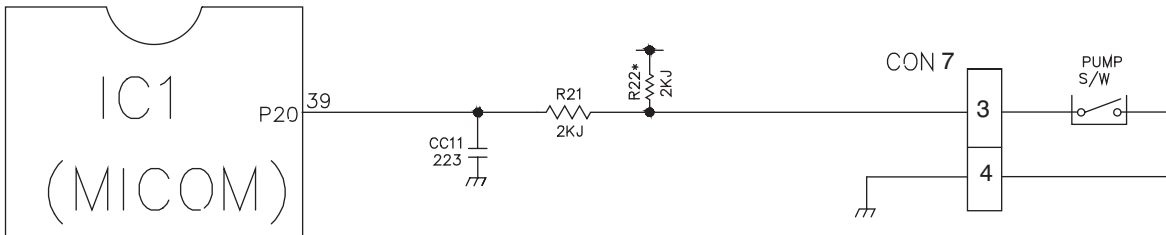

8-2-8 Temperature Compensation & Overcooling/Undercooling Compensation Circuit

1. Refrigerator Temperature Compensation

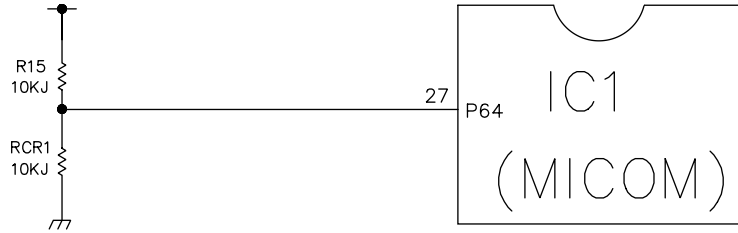

Refrigerator		Remark
Resistance (RCR)	Temperature Compensation	
180 KΩ	+2.5°C	Compensation by raising the temperature ↑
56 KΩ	+2.0°C	
33 KΩ	+1.5°C	
18 KΩ	+1.0°C	
12 KΩ	+0.5°C	
10 KΩ	0 °C	Standard Temperature
8.2 KΩ	-0.5°C	Compensation by lowering the temperature ↓
5.6 KΩ	-1.0°C	
3.3 KΩ	-1.5°C	
2 KΩ	-2.0°C	
470 Ω	-2.5°C	

▶ Table of Temperature Compensation by adjusting the resistance (difference from the current temperature) e.g., If the refrigerator compensation resistance (RCR) is changed from 10K (the current resistance) to 18K (the adjustment resistance), the temperature of the refrigerator rises 33.8°F(+1°C).

2. The temperature compensation for refrigerator compartment is in the following table:

	Revised resistance / Present resistance	470Ω	2kΩ	3.3kΩ	5.6kΩ	8.2kΩ	10kΩ	12kΩ	18kΩ	33kΩ	56kΩ	180kΩ
Refrigerator (RCR)	470Ω	No change	0.5°C Up	1°C Up	1.5°C Up	2°C Up	2.5°C Up	3°C Up	3.5°C Up	4°C Up	4.5°C Up	5°C Up
	2kΩ	0.5°C Down	No Change	0.5°C Up	1°C Up	1.5°C Up	2°C Up	2.5°C Up	3°C Up	3.5°C Up	4°C Up	4.5°C Up
	3.3kΩ	1°C Down	0.5°C Down	No Change	0.5°C Up	1°C Up	1.5°C Up	2°C Up	2.5°C Up	3°C Up	3.5°C Up	4°C Up
	5.6kΩ	1.5°C Down	1°C Down	0.5°C Down	No Change	0.5°C Up	1°C Up	1.5°C Up	2°C Up	2.5°C Up	3°C Up	3.5°C Up
	8.2kΩ	2°C Down	1.5°C Down	1°C Down	0.5°C Down	No Change	0.5°C Up	1°C Up	1.5°C Up	2°C Up	2.5°C Up	3°C Up
	10kΩ	2.5°C Down	2°C Down	1.5°C Down	1°C Down	0.5°C Down	No Change	0.5°C Up	1°C Up	1.5°C Up	2°C Up	2.5°C Up
	12kΩ	3°C Down	2.5°C Down	2°C Down	1.5°C Down	1°C Down	0.5°C Down	No Change	0.5°C Up	1°C Up	1.5°C Up	2°C Up
	18kΩ	3.5°C Down	3°C Down	2.5°C Down	2°C Down	1.5°C Down	1°C Down	0.5°C Down	No Change	0.5°C Up	1°C Up	1.5°C Up
	33kΩ	4°C Down	3.5°C Down	3°C Down	2.5°C Down	2°C Down	1.5°C Down	1°C Down	0.5°C Down	No Change	0.5°C Up	1°C Up
	56kΩ	4.5°C Down	4°C Down	3.5°C Down	3°C Down	2.5°C Down	2°C Down	1.5°C Down	1°C Down	0.5°C Down	No Change	0.5°C Up
	180kΩ	5°C Down	4.5°C Down	4°C Down	3.5°C Down	3°C Down	2.5°C Down	2°C Down	1.5°C Down	1°C Down	0.5°C Down	No Change

NOTE: This circuit is designed to input the necessary temperature compensation values into the MICOM. This adjusts the refrigerator temperature, which is different in each model.

8-2-9 Key Button Input & Display Light-On Circuit

The circuit shown above determines whether a function control key on the operation display is pushed. It also turns on the corresponding function indication LED Module SEVEN SEGMENT DISPLAY. The drive type is the scan type.

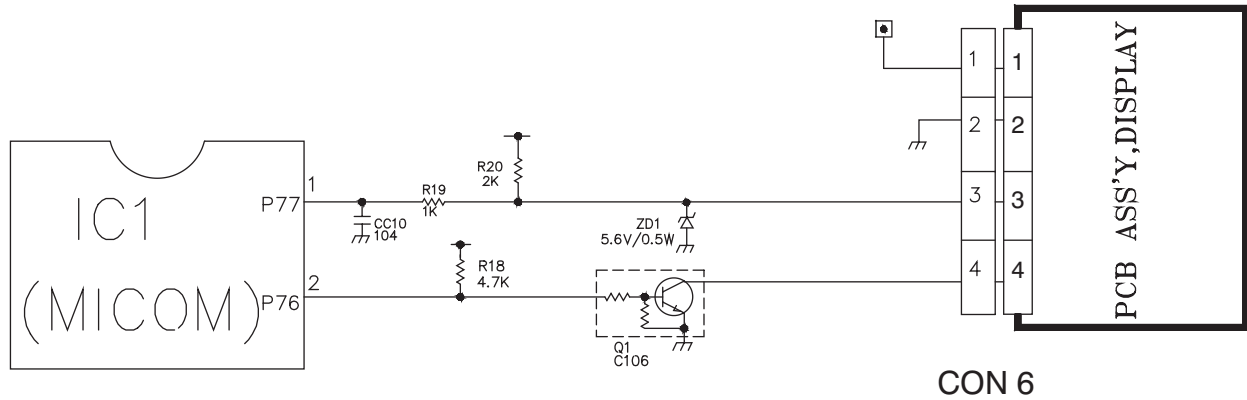

8-3 RESISTANCE SPECIFICATION OF SENSOR

TEMPERATURE	RESISTANCE OF FREEZER SENSOR	RESISTANCE OF REFRIGERATOR & DEFROST SENSOR & ROOM SENSOR
- 20 °C	22.3 KΩ	77 KΩ
- 15 °C	16.9 KΩ	60 KΩ
- 10 °C	13.0 KΩ	47.3 KΩ
- 5 °C	10.1 KΩ	38.4 KΩ
0 °C	7.8 KΩ	30 KΩ
+ 5 °C	6.2 KΩ	24.1 KΩ
+ 10 °C	4.9 KΩ	19.5 KΩ
+ 15 °C	3.9 KΩ	15.9 KΩ
+ 20 °C	3.1 KΩ	13 KΩ
+ 25 °C	2.5 KΩ	11 KΩ
+ 30 °C	2.0 KΩ	8.9 KΩ
+ 40 °C	1.4 KΩ	6.2 KΩ
+ 50 °C	0.8 KΩ	4.3 KΩ

- The resistance of the SENSOR has a $\pm 5\%$ common difference.
- Measure the resistance of the SENSOR after leaving it for over 3 minutes in the measuring temperature. This delay is necessary due to sensor response speed.

8-4 TROUBLESHOOTING

PROBLEM	INDICATED BY	CHECK	CHECKING METHOD	CAUSE	SOLUTION
POWER SOURCE is poor.	1. The whole DISPLAY LED/SEVEN SEGMENT DISPLAY is off. 2. DISPLAY LED/SEVEN SEGMENT DISPLAY operates abnormally	1. FREEZER/REFRIGERATOR.	Check if FREEZER/REFRIGERATOR DOOR IS OPEN and check display.	POWER SOURCE is poor.	Check outlet Voltage.
		2. If LAMP is dim. 3. The connection of the MAIN PWB CONNECTOR.	Check visually. Check connection of CONNECTOR.	Applied voltage error. CONNECTOR connection is poor. TRANS FUSE is open.	Use boosting TRANS. Reconnect CONNECTOR. Replace TRANS.
COOLING is poor.	NO COOLING.	1. If the COMPRESSOR operate.	USE TEST MODE1 (forced COOLING). If less than 7 minutes pass after compressor shuts off, don't press the KEY and wait.	COMPRESSOR locked or blocked. OLP, PTC is poor. COMPRESSOR RELAY is poor.	Replace COMPRESSOR. Replace OLP, PTC. Replace MAIN PWB.
			2. If refrigerant is leaking.	Refrigerant leakage.	Check the connection of the black wire of the MAIN PWB CONNECTOR (CON2). Replace the leaking part and replace any lost refrigerant.
		1. If FAN MOTOR operates. FREEZER TEMPERATURE is incorrect	USE TEST MODE1 (forced COOLING).	FAN MOTOR is poor. CONNECTING WIRE is poor.	Replace the FAN MOTOR. Refer to 8-2-4. 2 and check
			2. If DEFROSTING is normal. 3. If SENSOR is normal. 4. Door Line contact.	Check the amount of frost sticking on the EVAPORATOR. Check the resistance of the Refrigerator SENSOR. Check the seal when the door is closed.	DEFROSTING is poor. SENSOR RESISTANCE is poor. Door liner damaged.

PROBLEM	INDICATED BY	CHECK	CHECKING METHOD	CAUSE	SOLUTION
COOLING is poor.	If REFRIGERATOR TEMPERATURE is too low.	1. If FREEZER TEMPERATURE is normal.	Check is FREEZER TEMPERATURE is too low.		Make sure the DOOR is attached.
		2. If amount of cool air from FAN MOTOR is sufficient.	Make sure that the amount and speed of cool air are sufficient by touching the check supplied on the REFRIGERATOR.	FAN MOTOR is poor. Passage of cool air is blocked. EVA frozen.	Replace FAN MOTOR. Remove impurities. See DEFROSTING is poor.
		3. Door Line contact.	Check door seal when door is closed.	Door liner damaged.	Replace Door liner.
DEFROSTING is poor.	NO DEFROSTING.	1. If HEATER emits heat.	USE TEST MODE3 (forced DEFROSTING).	HEATER disconnection.	Replace HEATER.
				TEMPERATURE FUSE disconnection.	Replace TEMPERATURE FUSE.
				Connection is poor.	Check EVAPORATOR connection and wire of MAIN PWB CONNECTOR.
				DEFROST-SENSOR is poor.	Replace DEFROST-SENSOR.
				HEATER RELAY is poor.	Replace RY2 of MAIN PWB.
				DRAIN PIPE is blocked.	Remove ice and impurities. Check HEATER PLATE resistance.
				Connection is poor.	Reassemble the DEFROST-SENSOR.
3. If ice remains after DEFROSTING.	Make sure that DEFROST SENSOR is connected. Make sure that FREEZER / REFRIGERATOR DOOR is closed.	DOOR does not close properly.	Reassemble DOOR. Replace GASKET.		

8-5 MAIN PWB ASSEMBLY AND PARTS LIST

8-5-1 Main PWB Assembly

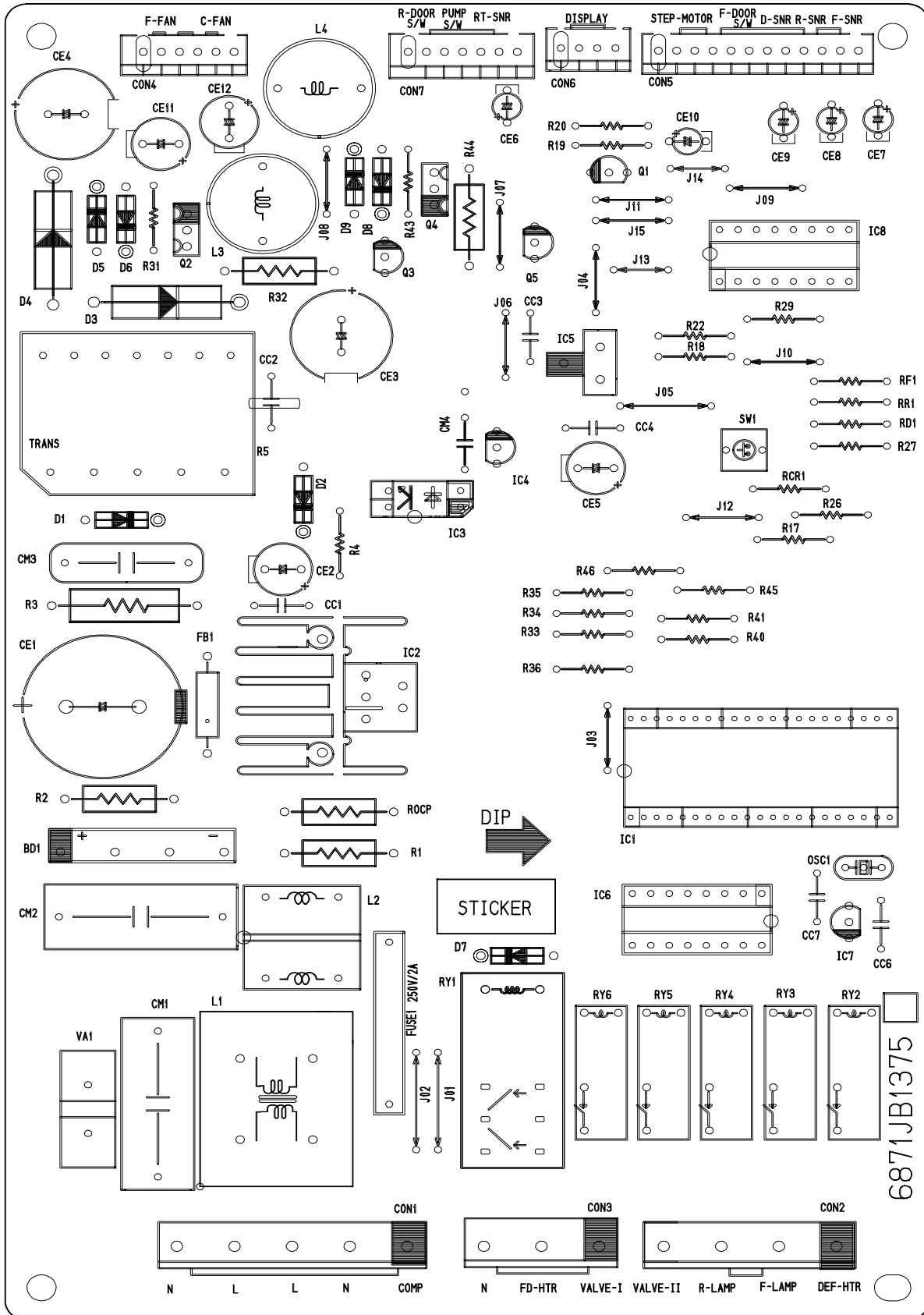

8-5-2 Replacement Parts List

No	P/NO	DESCRIPTION	SPEC	MAKER	REMARK
1	6870JB8203A	PWB(PCB)	BEST BRAVO-PJT	DOO SAN	T=1.6
2	6170JB2012B	TRANSFORMER SMPS(COIL)	DL-PJT 2.9MH/20W	SAM IL	TRANS
3	6170JB2012C	TRANSFORMER SMPS(COIL)			TRANS
4	6630AQ9106D	CONNECTOR (CIRC) WAFER	YW396-09AV	YEON HO	CON1
5	6630AQ9106E	CONNECTOR (CIRC) WAFER	YW396-07AV	YEON HO	CON2
6	6630AQ9106B	CONNECTOR (CIRC) WAFER	YW396-05AV	YEON HO	CON3
7	6630JB8004E	CONNECTOR (CIRC) WAFER	SMW250 YEONHO 6P 2.5MM STRAIGHT SN	YEON HO	CON4
8	6630JB8004L	CONNECTOR (CIRC) WAFER	SMW250 YEONHO 12P 2.5MM STRAIGHT SN	YEON HO	CON5
9	6630JB8004C	CONNECTOR (CIRC) WAFER	SMW250 YEONHO 4P 2.5MM STRAIGHT SN	YEON HO	CON6
10	6630JB8004F	CONNECTOR (CIRC) WAFER	SMW250 YEONHO 7P 2.5MM STRAIGHT SN	YEON HO	CON7
11	01ZZJB2054V	IC DRAWING	TMP87C846N 42P SDIP BK MASK BRAVO33-PJT BEST/BETTER	TOSHIBA	IC1
12	01SK635100A	IC POWER MANAGEMENT	STR-G6351 5PIN BK SMPS 2.4PIN FORM	SANKEN	IC2
13	01PMGN001A	IC POWER MANAGEMENT	PS2561L1-1-V NEC 4PDIP BK = TLP721F	NEC	IC3
14	01KE431000A	IC KECC	KIA431 3 PIN TP -	KEC	IC4
15	01KE780500Z	IC LINEAR	KIA7805P1 3DIP BK 5V 1A REFORM	KEC	IC5
16	01KE650030B	IC KECC	KID65003AP 16P SDIP BK DRIVE IC	KEC	IC6
17	01KE704200A	IC KECC	KIA7042P KEC 3P BK RESET	KEC	IC7
18	01T0777400A	IC DRAWING	TA7774AP 16 SDIP BK DRIVE IC STEPPING MOTOR	TOSHIBA	IC8
19	6920AL2001B	RELAY	ALZ12B12 NAIS 250VAC 16A 12VDC 1A NO VENTING	NAIS	RY1
20	6920JB2003A	RELAY	GSN-1A OMRON 250VAC 1.5A 12VDC 1A JAPAN	OMRON	RY5,RY6
21	6920JB2003E	RELAY	GSN8-1A-E(CHINA) OMRON 250VAC 5A 12VDC 1A NO VENTING	OMRON	RY2-4
22	6920JB2009B	RELAY	GS58-14 OMRON 250VAC 5A 12VDC 1C NO VENTING	OMRON	-
23	-	-	-	-	-
24	6212JB8001B	RESONATOR CERAMIC	CST50400MG03 MURATA 4MHZ TP -	MURATA	OSC1
25	6102JB8001B	VARISTOR	INR14D621 ILJIN ULVDE BK 620V	ILJIN	VA1
26	6102W5V007A	VARISTOR	INR14D331K ILJIN ULVCSAVDE BK	ILJIN	VA1
27	0DB360000AA	DIODE RECTIFIERS	D3SBA80 BK SHINDENGEN - 600V 4A 80A - 10UA	SHINDENGEN	BD1
28	0DD40409AC	DIODE RECTIFIERS	RECT1M4094 TP	DELTA	D7
29	0DR107009AA	DIODE RECTIFIERS	FR107 TP RECTRON D041 1000V 1A 30A 500NSC 5A	DELTA	D1 D2 D5 D6 D8 D9
30	0DRSA00070A	DIODE RECTIFIERS	RL2 SANKEN BK NON 400V 2A 40A 50NSC 10UA	SANKEN	D3 D4
31	0CE105BK638	CAPACITOR FIXED ELECTROLYTIC	1UF KME RGYX 50V 0.2 FMS TP 5	SAM WHA	CE10
32	0CE106EK638	CAPACITOR FIXED ELECTROLYTIC	10UF KMG 50V 20% FMS TP 5	SAM WHA	CE8-CE9
33	0CE227BF638	CAPACITOR FIXED ELECTROLYTIC	220UF KME TYPE 16V 20% FMS TP 5	SAM WHA	CE5
34	0CE227BH638	CAPACITOR FIXED ELECTROLYTIC	220UF KME RG 25V 20% FMS TP 5	SAM WHA	CE11,CE12
35	-	-	-	-	-
36	0CE476BK638	CAPACITOR FIXED ELECTROLYTIC	47UF KME TYPE 50V 20% FMS TP 5	SAM WHA	CE2
37	0CE476ZV6E0	CAPACITOR FIXED ELECTROLYTIC	47UF HE 450V 20% BULK SNAP IN	SAM WHA	CE1
38	0CE687YH6E0	CAPACITOR FIXED ELECTROLYTIC	680UF RX 25V 20% BULK SNAP IN	SAM WHA	CE3
39	0CE687YJ618	CAPACITOR FIXED ELECTROLYTIC	680UF RX 35V 20% TP 5 FL	SAM WHA	CE4
40	0CK102DK96A	CAPACITOR FIXED CERAMIC(HIGH DIELECTRIC)	1NF 2012 50V 80% -20% R/TP X7R	MURATA	CC17,CC20
41	0CK1040K949	CAPACITOR FIXED CERAMIC(High dielectric)	0.1UF D 50V 80% -20% F(V5V) TA52	SAM WHA	CC3,CC4,CC6,CC7
42	0CK104DK98A	CAPACITOR FIXED CERAMIC(High dielectric)	0.1UF 2012 50V 80% -20% R/TP JE	MURATA	CC5,CC10
43	0CK22102510	CAPACITOR FIXED CERAMIC(High dielectric)	220P 2KV K B S	SAM WHA	CC2
44	0CK2230K949	CAPACITOR FIXED CERAMIC(High dielectric)	22NF 50V Z F TA52	SAM WHA	-
45	0CK223DK96A	CAPACITOR FIXED CERAMIC(HIGH DIELECTRIC)	22NF 2012 50V 80% -20% R/TP X7R	MURATA	CC8,CC9,CC11-15,CC18
46	0CK4710K519	CAPACITOR FIXED CERAMIC(High dielectric)	470PF 50V K B TA52	SAM WHA	CC1
47	0CO1041N509	CAPACITOR FIXED FILM	0.1UF D 100V 10% PE TP5	SAM WHA	CM4
48	0CK102DK96A	CAPACITOR FIXED CERAMIC(HIGH DIELECTRIC)	1NF 2012 50V 80% -20% R/TP X7R	MURATA	CC20
49	0CO4732V430	CAPACITOR FIXED FILM	47000PF S 630V 5% MPE NI R	SAM WHA	CM3
50	0CO47418670	CAPACITOR FIXED FILM	0.47UF D 275V 20% MPP NI R	SAM WHA	CM1
51	0LR1001M4F0	INDUCTOR RADIAL LEAD	1000UH 20% R 6X12.5 BULK	TNC	L3,L4
52	0RD1001G609	RESISTOR FIXED CARBON FILM	1K OHM 1/4 W 5% TA52	SMART	R19
53	0RD1002G609	RESISTOR FIXED CARBON FILM	10K OHM 1/4 W 5% TA52	SMART	R29 R35 RCR1
54	0RD2001G609	RESISTOR FIXED CARBON FILM	2K OHM 1/4 W 5% TA52	SMART	R17 R20 R21 R22 R26 R27 R36
55	0RD3901G609	RESISTOR FIXED CARBON FILM	3.9K OHM 1/4 W 5% TA52	SMART	R34 R41
56	0RD4710G609	RESISTOR FIXED CARBON FILM	4.7K OHM 1/4 W 5% TA52	SMART	R18 R33 R40
57	0RD5603H609	RESISTOR FIXED CARBON FILM	560K OHM 1/2 W 5% TA52	SMART	R2
58	0RD2001G609	RESISTOR FIXED CARBON FILM	2K OHM 1/4 W 5% TA52	SMART	R45
59	0RD4701G609	RESISTOR FIXED CARBON FILM	4.7K OHM 1/4 W 5% TA52	SMART	R46
60	0RJ2701L622	RESISTOR METAL GLAZED(CHIP)	2.7K OHM 1/8 W 5% 2012 R/TP	ROHM	R21
61	0RH1002L622	RESISTOR METAL GLAZED(CHIP)	10KOHM 1/8 W 5% 2012 R/TP	ROHM	R15,R28,R30,R42,R8
62	0RH1004L622	RESISTOR METAL GLAZED(CHIP)	1M OHM 1/8 W 5% 2012 R/TP	ROHM	R13
63	0RH1001L622	RESISTOR METAL GLAZED(CHIP)	1K OHM 1/8 W 5% 2012 5.00% D	ROHM	R7
64	0RH2001L622	RESISTOR METAL GLAZED(CHIP)	2K OHM 1/8 W 5% 2012 R/TP	ROHM	R23,R25,R38,R39
65	0RH3300L622	RESISTOR METAL GLAZED(CHIP)	33K OHM 1/8 W 5% 2012 R/TP	ROHM	R1,R43
66	0RH4701L622	RESISTOR METAL GLAZED(CHIP)	4.7K OHM 1/8 W 5% 2012 R/TP	ROHM	R14,R16,R37
67	0RD1000E672	RESISTOR METAL GLAZED(CHIP)	10K OHM 1/8 W 5% 2012 R/TP	ROHM	R5
68	0RD1501H609	RESISTOR FIXED CARBON FILM	1.5K OHM 1/2 W 5% TA52	SMART	R32,R44
69	0RJ0000E672	RESISTOR METAL GLAZED(CHIP)	0 OHM 1/8 W 5% 2012 R/TP	ROHM	RJ1
70	0RJ2401E472	RESISTOR METAL GLAZED(CHIP)	2.4K OHM 1/8 W 1% 2012 R/TP	ROHM	RL2
71	0RJ6800E672	RESISTOR METAL GLAZED(CHIP)	680 OHM 1/8 W 5% 2012 R/TP	ROHM	R6
72	0RD6801G609	RESISTOR FIXED CARBON FILM	6.8K OHM 1/4 W 5% TA52	SMART	R4
73	0RJ9101E472	RESISTOR METAL GLAZED(CHIP)	9.1K OHM 1/8 W 1% 2012 R/TP	ROHM	RL4
74	0RJ1002E472	RESISTOR FIXED METAL FILM	10K OHM 1/8 W 1.00% 2012 R/TP	ROHM	RT1
75	0RN1622G409	RESISTOR FIXED METAL FILM	16.2K OHM 1/4 W 1.00% TA52	SMART	RF1
76	0RN2612G409	RESISTOR FIXED METAL FILM	26.1K OHM 1/4 W 1.00% TA52	SMART	RF1, RD1
77	0RS0151J609	RESISTOR FIXED METAL OXIDE FILM	1.5 OHM 1 W 5.00% TA52	SMART	ROCP
78	0RS0101J609	RESISTOR FIXED METAL OXIDE FILM	1 OHM 1 W 5% TA52	SMART	ROCP
79	0RS5602K641	RESISTOR FIXED METAL OXIDE FILM	56K OHM 2 W 5.00% F20	SMART	R3
80	0RS3303J609	RESISTOR FIXED METAL OXIDE FILM	330K OHM 1 W 5.00% TA52	SMART	R1
81	0TR319809AA	TRANSISTOR	KTC3198-TP-Y (KTC1815)KECC	KEC	Q3,Q5
82	0TRKE00008A	TRANSISTOR BIPOLARS	KEC KTB1151 BK T0126 80V 5A	KEC	Q2,Q4
83	0TRKE80016A	TRANSISTOR BIPOLARS	KEC KRC106S R/TP SOT23 50V 100MA	KEC	Q1
84	6200JB8004A	FILTER(CIRC) EMC	CV940050 TNC -	TNC	L1
85	6200JB8007X	FILTER(CIRC) EMC	UV11-05320 TNC BK 0.5A 320MH	TNC	L2
86	6210JB8001A	FILTER(CIRC) EMC	BFS3510A0 SAMWHA TP52 BEAD FILTER	SAM WHA	FB1
87	6600RR7001Z	SWITCH TACT	JTP-1280A6 JEIL 12VDC 30MA -	JEIL	SW1
88	0DZMR00029A	DIODE ZENERS	1NS232B MOTORORA TP D034 0.5W 5.6V 81MA PF	DEL TA	ZD1
89	6854850001A	JUMP WIRE	0.6MM 52MM TP TAPING SN	DAE A LEAD	J03,J04,J06-J12,J15(10MM)
90	0FZZJB3001A	FUSE DRAWING	2A 250V - SLOW-BLOW LITTELFUSE,TRIAD	SAM JU KYO YUK	J13,J14(8MM)
91	1S8F0302418	SCREW TAP TITE(S) BINDING HEAD	+ D3.0 L8.0 MSWR3/FZY	HAENG SUNG	J01,J02,J05(12.5MM) FUSE1
92	4920JB3007A	HEAT SINK	23.3*17*25 DRIVE IC STR R-S64.65 73 2PIN 1-SCREW 3MM -	(IC2)	(IC2)
93	49111004	SOLDER SOLDERING	NA HEESUNG METAL BAR SN 63% NA	-	-
94	59333105	FLUX	JS-71 KOKI SANEI KOREA(KSK) SG.0.808 +/-0.003	-	-
95	9VWF0120000	SOLDER(ROSIN WIRE) R50	D1.20	-	-

8-5-3 PWB Assembly, Display, And Parts List

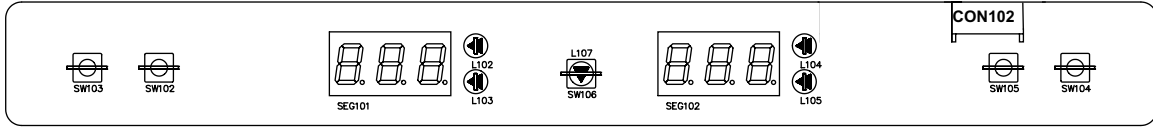

A		WORK					
QTY	No	P/N	DESCRIPTION	SPEC	MAKER	REMARK	
1	1	6870J88199A	FWB(PCB)	BRAVO 33 DISPLAY			
1	2	6630J88030C	CONNECTOR IC(RCL) WAFER	SMAW250-04	YCON HO	CON01	
1	3	02Z877777	IC DRAWING	TM97C40PM 28, SCF28-P-450 BRAVO 33	IC808A	IC1	
1	4	05TLM1001A	IC STANDARD LOGIC	MS4545FP MIX8B84 20 R/P CONVERT	MITSUBISHI	IC4	
1	5	0W555030C	IC KEC	KE2A5003AF 15SCP BK 7CH DRIVER	KEC	IC5, IC6	
1	6	05TLK6002A	IC STANDARD LOGIC	KA78L05F KEC SCF-69 TP REGULATOR	KEC	IC2	
1	7	05TLK6003A	IC STANDARD LOGIC	KA78L02AF KEC SCF-69 TP RESET IC	KEC	IC3	
1	8	05TLK6005A	IC STANDARD LOGIC	KRC1065 KEC SCF-23 TP TRANSISTOR	KEC	Q1	
1	9	6212883245A	RESONATOR CERAMIC	C5CR4M00563-R0 MURATA 4.0MHz +/- 0.5% 1R SMD	MURATA	OSC1	
1	10	0CE476V40C	CAPACITOR FIXED ELECTRIC	47UF MV 25V 20% R/TP(SMD) SMD	SAMWHA	CE2	
1	11	0CE107V40C	CAPACITOR FIXED ELECTRIC	100UF MV 16V 20% R/TP(SMD) SMD	SAMWHA	CE1	
7	12	0CK104K96A	CAPACITOR FIXED CERAMIC	100NF 2012 50V 80% -20% R/TP FHSV1	MURATA	CC1-CC7	
2	13	0CK102K96A	CAPACITOR FIXED CERAMIC	1NF 2012 50V 80% -20% R/TP X7R	MURATA	CC8-CC9	
1	14	0R42001A22	RESISTOR METAL GLAZED (CHP)	220 OHM 1/8 W 5% 2012 5.00% D	ROHM	R5	
2	15	0R10011A72	RESISTOR METAL GLAZED (CHP)	1K OHM 1/8 W 5% 2012 R/TP	ROHM	R3, R4	
1	16	0R20011A72	RESISTOR METAL GLAZED (CHP)	2K OHM 1/8 W 5% 2012 R/TP	ROHM	R2	
6	17	0R47011A72	RESISTOR METAL GLAZED (CHP)	4.7K OHM 1/8 W 5% 2012 R/TP	ROHM	R1, R7, R21-R24	
1	18	0R1004E672	RESISTOR METAL GLAZED (CHP)	1M OHM 1/8 W 5% 2012 R/TP	ROHM	R6	
9	19	0R82004E72	RESISTOR METAL GLAZED (CHP)	820 OHM 1/2 W 5% 2012 R/TP	ROHM	RB-R16	
2	20	0R82001L622	RESISTOR METAL GLAZED (CHP)	2K OHM 1/8 W 5% 2012 5.00% D	ROHM	R17, R19	
2	21	0R11000L622	RESISTOR METAL GLAZED (CHP)	100 OHM 1/2 W 5% 2012 R/TP	ROHM	R18-R20	
1	22	0D39M00188A	DIODE ZENERS	R1Z OHM R/TP L10SLL-341 500MW 5.6V 20MA PF	ROHM	ZD1	
5	23	0D39M00068A	DIODE SWITCHING	RLS4148 ROHM R/TP L10SLL-341 75V 450MA 2000MA	ROHM	D108-D112	
-	24	0D0414809AA	DIODE SWITCHING	IN4149 26 MM	PUNG CHANG DELTA	-	
2	25	6327J88001A	DISPLAY LED ASSEMBLY	IN4023-1SERIES GREEN 2.1V 1.7mCD	LEDTECH	SEG1, SEG2	
4	26	0CL1E099AA	LED	138323-41 RCN 2.1V D3 P GREEN	LEDTECH	L102, L105	
-	27	0CL1E099AA	LED	138323-41 RCN 2.1V D3 TP GREEN	LEDTECH	L101, L107	
1	28	699J83002D	BULZER	PQ272207R-20C-2000 SUNWAY PHOTO 2HZ 80DB (CHINA)	SUNWAY	BULZER	
4	29	660QJ88005A	SWITCH TACT	KPT-1105A	KYUNG IN	SW102, SW105	
-	-	660QJ88002K	SWITCH TACT	JPP1230A JEL 12V DC 50MA	JEL	-	
1	30	660QJ88004A	SWITCH TACT	KPT-1109R	KYUNG IN	SW106	
-	-	-	SWITCH TACT	KPT-1109S	KYUNG IN	-	
2g	31	49111001	SOLDER, SOLDERING	SOLDR (ROSN WIRE) R50	HUSUNG	-	
5g	32	49111004	SOLDER, SOLDERING	H63A	HUSUNG	-	
0.5g	33	59333105	FLUX	SS; 0.825-0.830 KOREA FH-206	KCKI	-	

8-6 PWB DIAGRAM

8-6-1 PWB Main Assembly

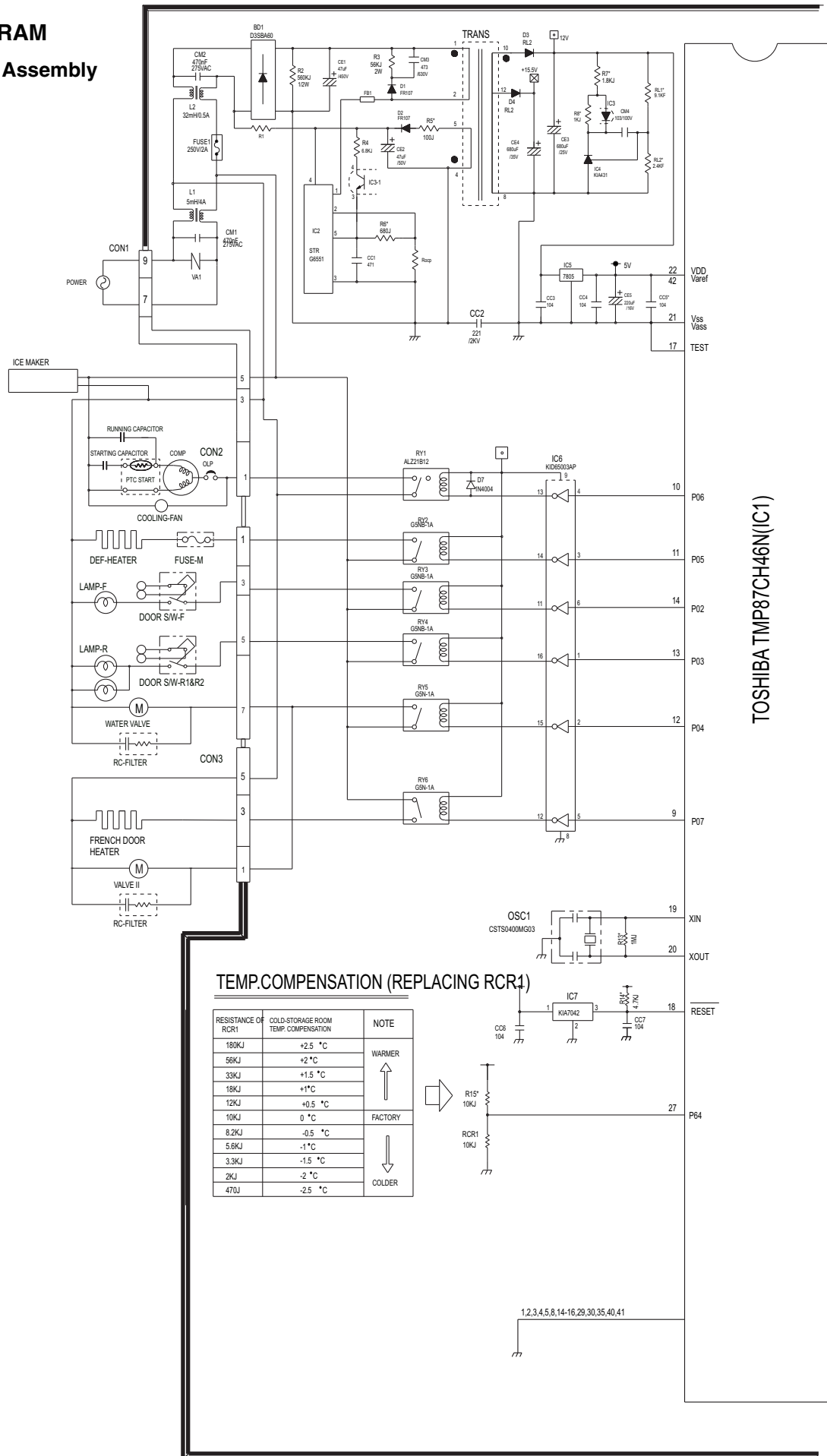

TOSHIBA TMP87CH46N(IC1)

TEMP. COMPENSATION (REPLACING RCR4)

RESISTANCE OF RCR1	COLD-STORAGE ROOM TEMP. COMPENSATION	NOTE
180KJ	+2.5 °C	↑ WARMER
56KJ	+2 °C	
33KJ	+1.5 °C	
18KJ	+1 °C	
12KJ	+0.5 °C	
10KJ	0 °C	FACTORY
8.2KJ	-0.5 °C	↓ COLDER
5.6KJ	-1 °C	
3.3KJ	-1.5 °C	
2KJ	-2 °C	
470J	-2.5 °C	

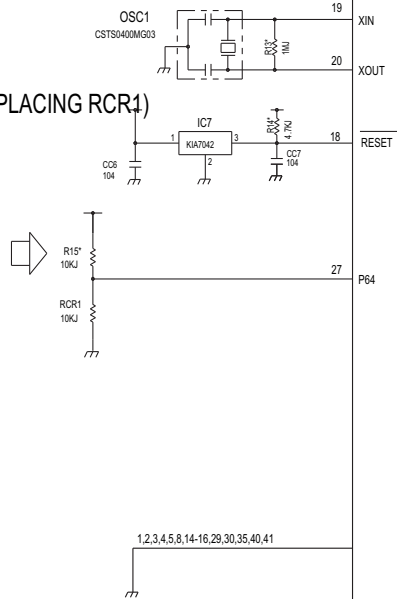

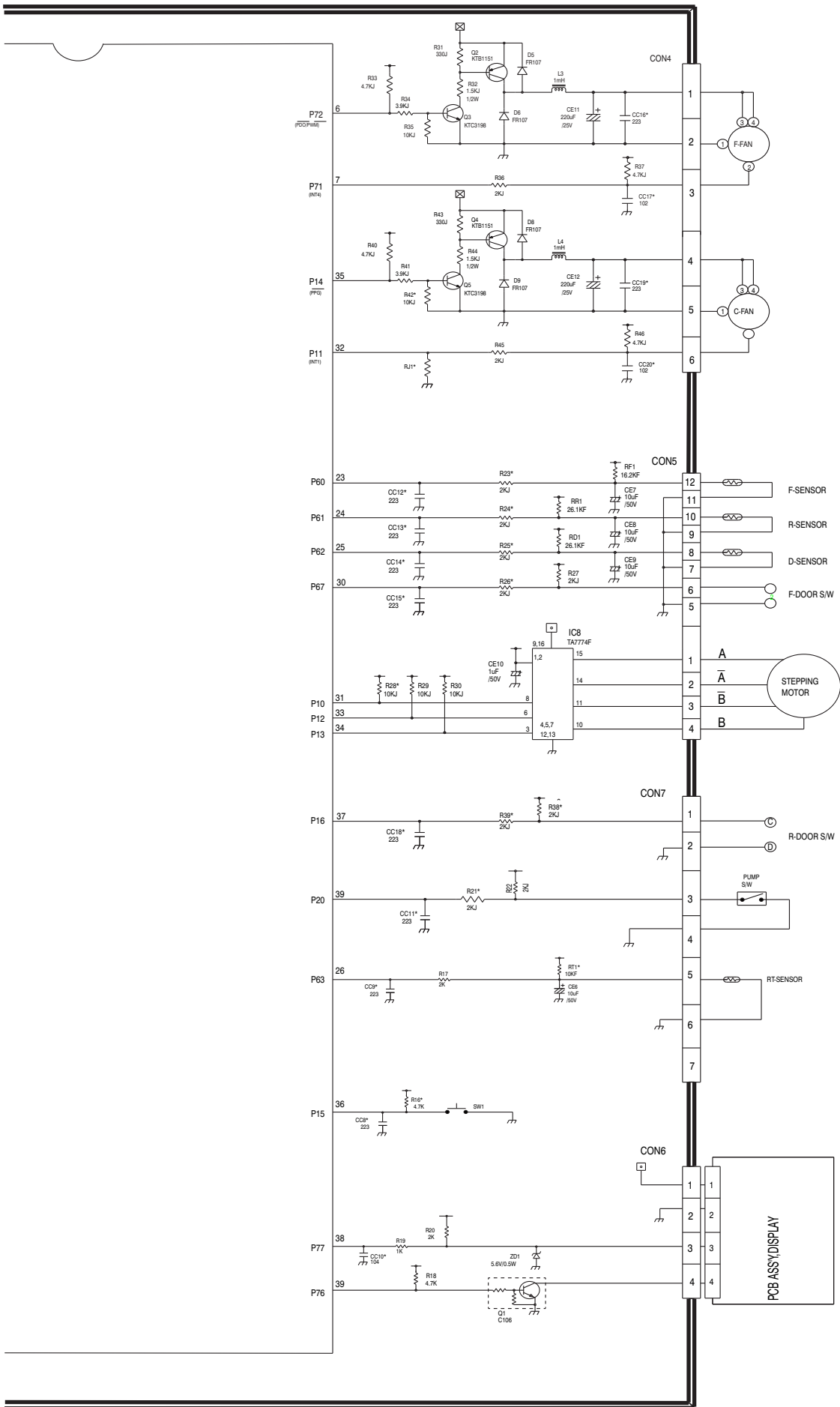

9. EXPLODED VIEW & REPLACEMENT PARTS LIST

CASE PARTS

CAUTION: Use the part number to order part, not the position number.

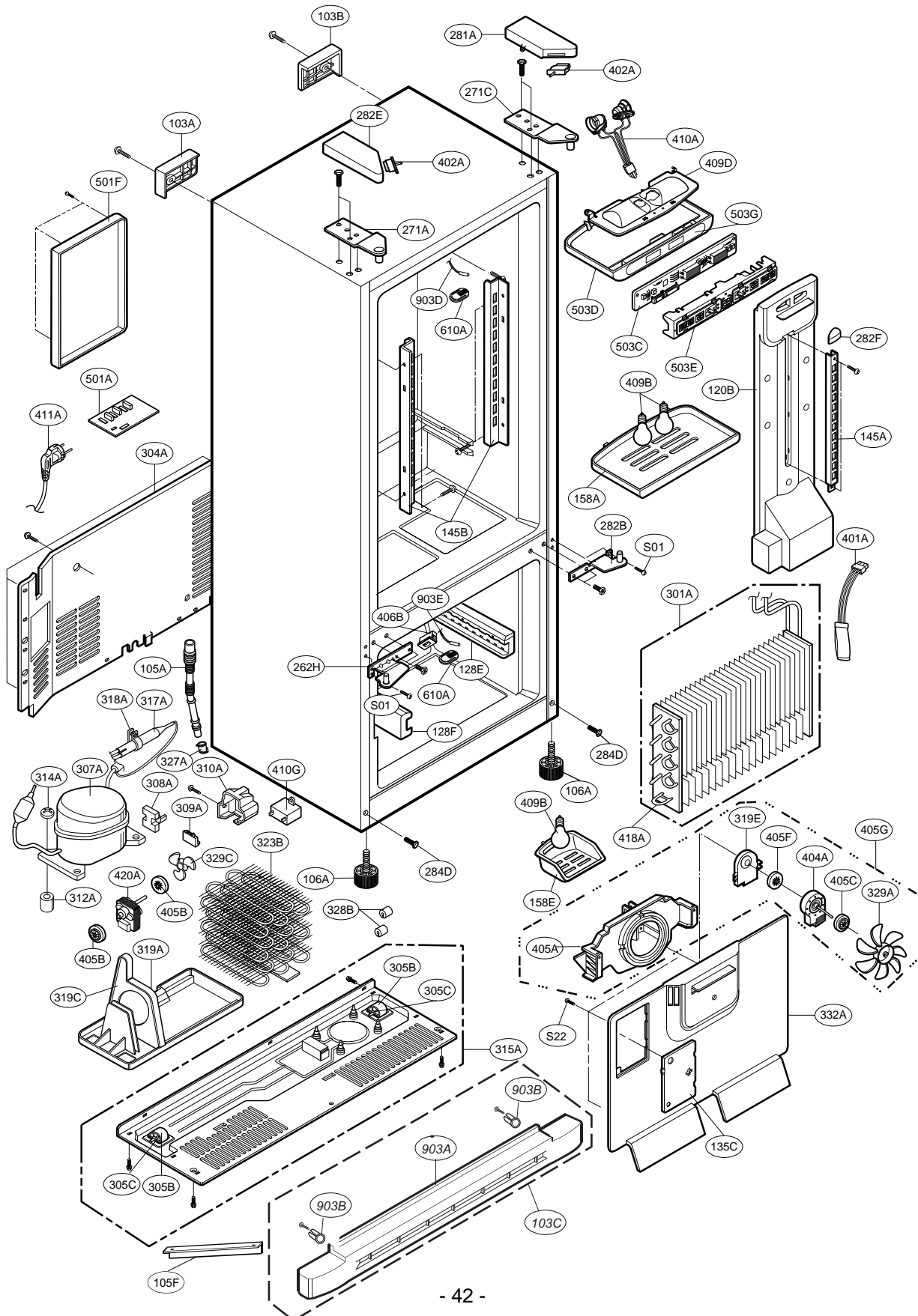

FREEZER PARTS

CAUTION: Use the part number to order part, not the position number.

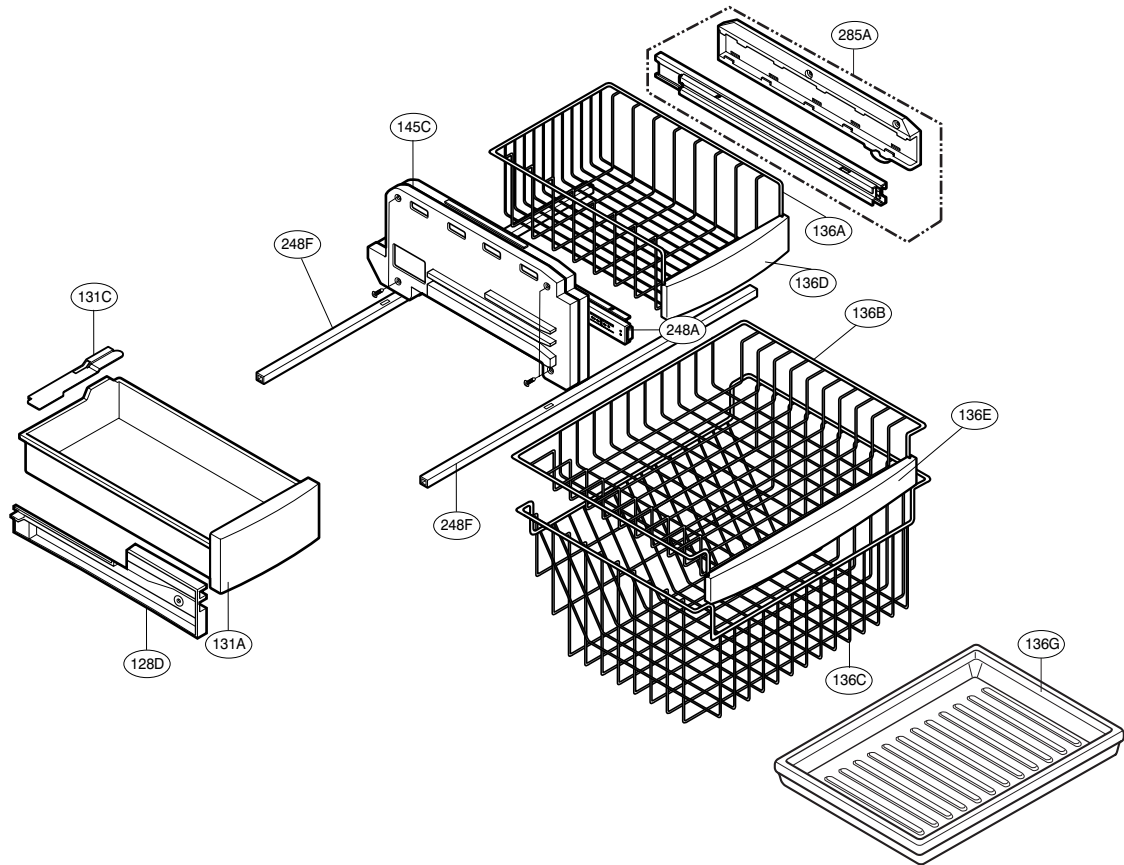

REFRIGERATOR PARTS

CAUTION: Use the part number to order part, not the position number.

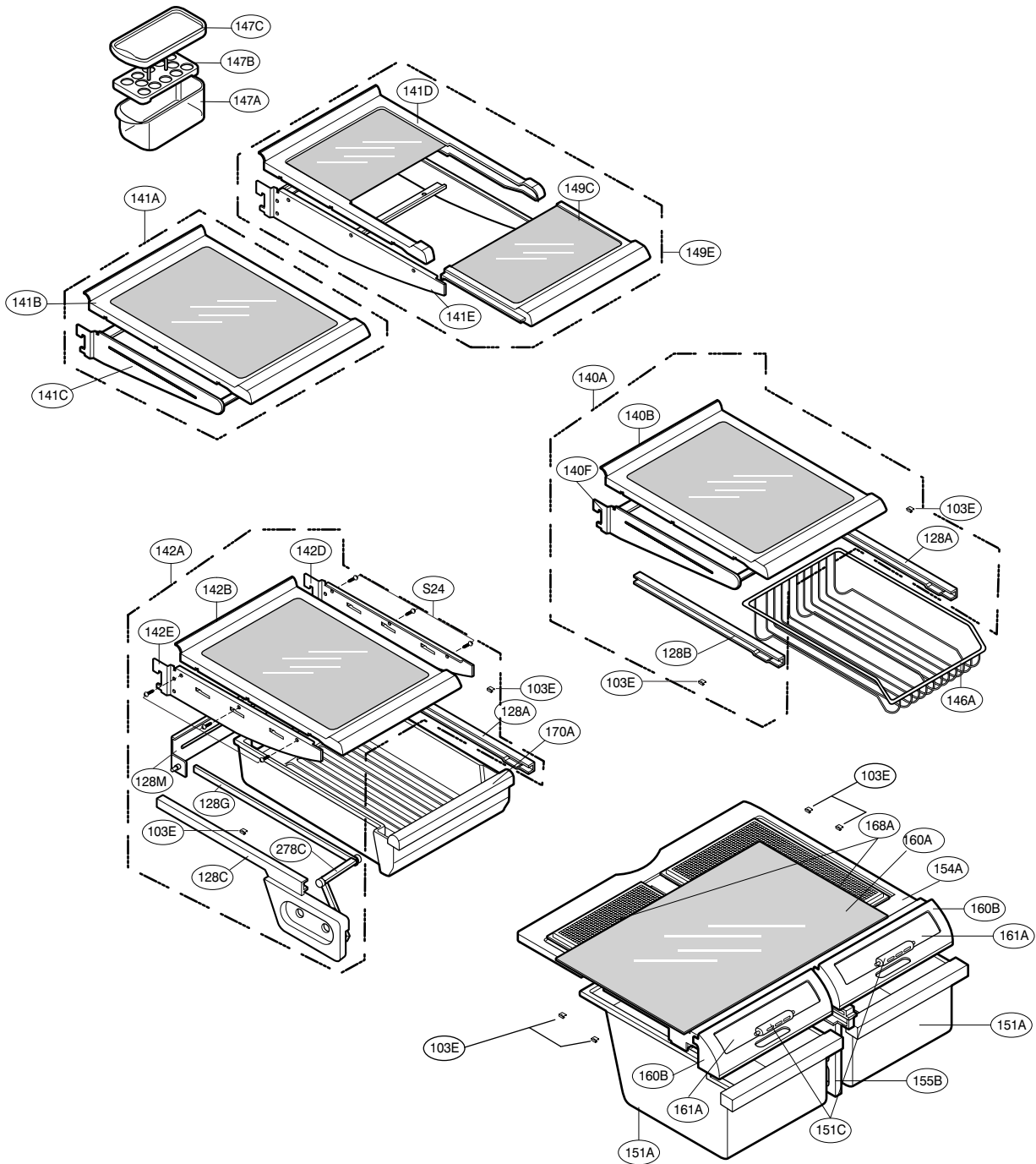

* : on some models

DOOR PARTS

CAUTION: Use the part number to order part, not the position number.

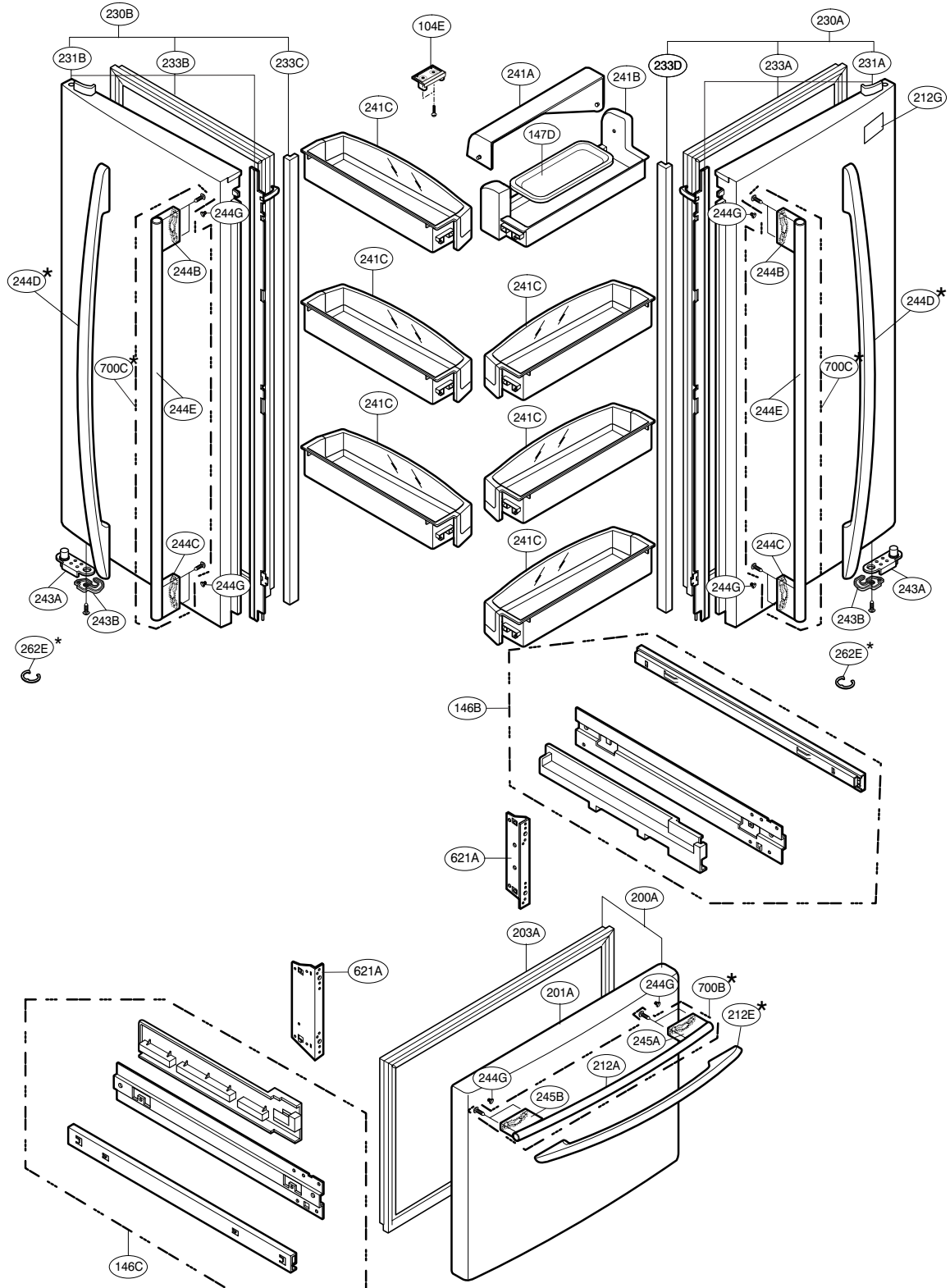

* : on some models

ICE MAKER PARTS

CAUTION: Use the part number to order part, not the position number.

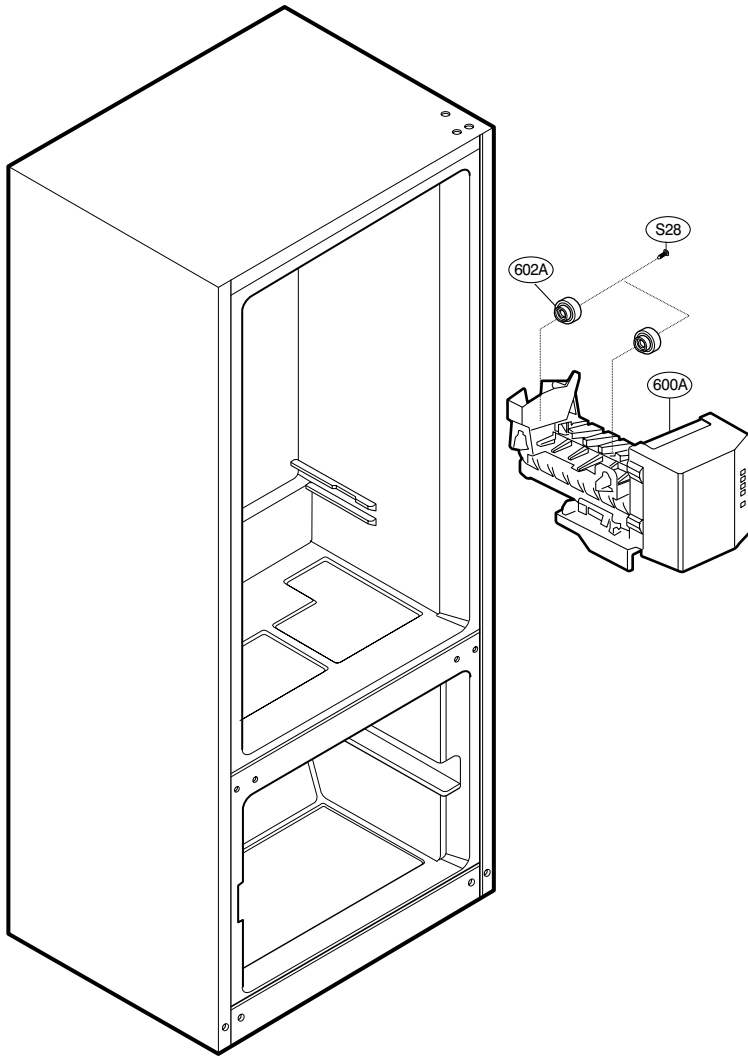

ICE & WATER PARTS

CAUTION: Use the part number to order part, not the position number.

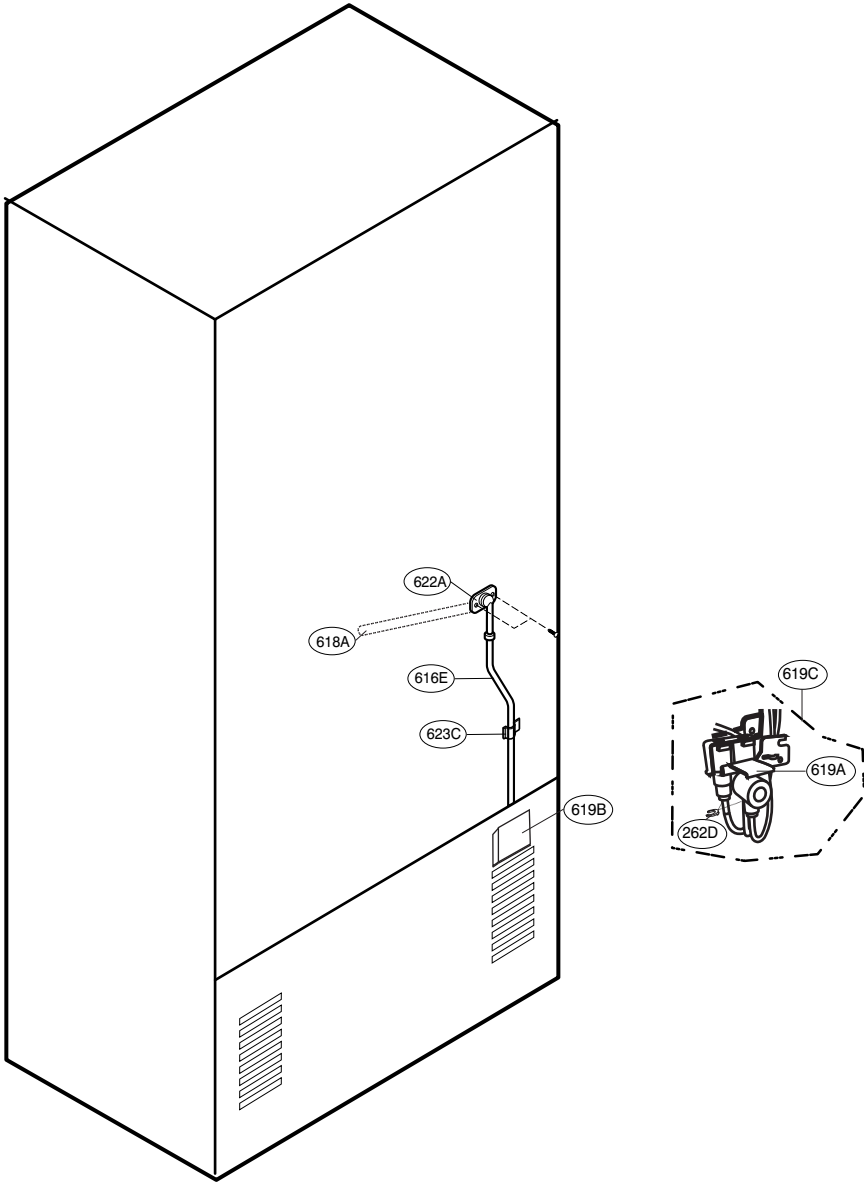

LOC	DESCRIPCION	LRFC22750TT	LRFC22750SW	LRFC22750ST
103A	HANDLE,BACK	3650JJ2003H	3650JJ2003E	3650JJ2003L
103B	HANDLE,BACK	3650JJ2003D	3650JJ2003A	3650JJ2003M
103C	COVER ASSEMBLY,LOWER	3551JJ1015H	3551JJ1015B	3551JJ1015F
103E	RAIL,SLIDE	5218JJ3001A	5218JJ3001A	5218JJ3001A
103E	RAIL,SLIDE	5218JJ3001A	5218JJ3001A	5218JJ3001A
103E	RAIL,SLIDE	5218JJ3001A	5218JJ3001A	5218JJ3001A
103E	RAIL,SLIDE	5218JJ3001A	5218JJ3001A	5218JJ3001A
103E	RAIL,SLIDE	5218JJ3001A	5218JJ3001A	5218JJ3001A
103E	RAIL,SLIDE	5218JJ3001A	5218JJ3001A	5218JJ3001A
104E	HOLDER ASSEMBLY,GASKET	4931JJ3002A	4931JJ3002A	4931JJ3002A
105A	DRAIN ASSEMBLY,PIPE-Z	5251JA3003B	5251JA3003B	5251JA3003B
105F	SKIRT,LOWER	5070JJ3002A	5070JJ3002A	5070JJ3002A
106A	LEG ASSEMBLY,ADJUST	4779JA2003A	4779JA2003A	4779JA2003A
120B	DUCT ASSEMBLY,MULTI	5209JJ1002A	5209JJ1002A	5209JJ1002A
128A	GUIDE ASSEMBLY,RAIL	4975JJ2002A	4975JJ2002A	4975JJ2002A
128A	GUIDE ASSEMBLY,RAIL	4975JJ2002A	4975JJ2002A	4975JJ2002A
128B	GUIDE ASSEMBLY,RAIL	4975JJ2002B	4975JJ2002B	4975JJ2002B
128C	GUIDE ASSEMBLY,RAIL	4975JJ2003C	4975JJ2003C	4975JJ2003C
128D	GUIDE,RAIL	4974JJ2035A	4974JJ2035A	4974JJ2035A
128E	HOLDER,RAIL	4930JJ1011C	4930JJ1011C	4930JJ1011C
128F	HOLDER,RAIL	4930JJ1011D	4930JJ1011D	4930JJ1011D
128G	LINK	4520JJ2001A	4520JJ2001A	4520JJ2001A
128M	GUIDE,AIR	4974JJ2011A	4974JJ2011A	4974JJ2011A
131A	BANK,ICE	5074JL1001B	5074JL1001B	5074JL1001B
131C	COVER,BANK ICE	3550JJ2045A	3550JJ2045A	3550JJ2045A
135C	COVER,GRILLE FAN	3550JJ2030A	3550JJ2030A	3550JJ2030A
136A	TRAY,DRAWER	3390JJ1062A	3390JJ1062A	3390JJ1062A
136B	TRAY,DRAWER	3390JJ1059A	3390JJ1059A	3390JJ1059A
136C	TRAY ASSEMBLY,DRAWER	3391JJ1012C	3391JJ1012C	3391JJ1012C
136D	DECO,TRAY	3806JL1020B	3806JL1020B	3806JL1020B
136E	DECO,TRAY	3806JL1024B	3806JL1024B	3806JL1024B
136G	TRAY,DRAWER	3390JJ1036A	3390JJ1036A	3390JJ1036A
140A	SHELF ASSEMBLY,R	5027JJ1014D	5027JJ1014D	5027JJ1014D
140B	SHELF ASSEMBLY,R	5027JJ1005A	5027JJ1005A	5027JJ1005A
140F	SHELF ASSEMBLY,NET	5027JJ2005F	5027JJ2005F	5027JJ2005F
141A	SHELF ASSEMBLY,R	5027JJ1014B	5027JJ1014B	5027JJ1014B
141B	SHELF ASSEMBLY,R	5027JJ1005A	5027JJ1005A	5027JJ1005A
141C	SHELF ASSEMBLY,NET	5027JJ2005C	5027JJ2005C	5027JJ2005C
141D	SHELF ASSEMBLY,R	5027JJ2011B	5027JJ2011B	5027JJ2011B
141E	SHELF ASSEMBLY,NET	5027JJ2005D	5027JJ2005D	5027JJ2005D
142A	SHELF ASSEMBLY,R	5027JJ1013U	5027JJ1013U	5027JJ1013U
142B	SHELF ASSEMBLY,R	5027JJ1006A	5027JJ1006A	5027JJ1006A
142D	SHELF,NET	5026JJ2001L	5026JJ2001L	5026JJ2001L
142E	SHELF,NET	5026JJ2001M	5026JJ2001M	5026JJ2001M
145A	HOLDER,SHELF	4930JJ2003A	4930JJ2003A	4930JJ2003A
145B	HOLDER,SHELF	4930JJ2004A	4930JJ2004A	4930JJ2004A

LOC	DESCRIPCION	LRFC22750TT	LRFC22750SW	LRFC22750ST
145C	GUIDE ASSEMBLY,RAIL	4975JJ1001C	4975JJ1001C	4975JJ1001C
146A	CAN,SERVER	5044JJ1001A	5044JJ1001A	5044JJ1001A
146B	CONNECTOR ASSEMBLY (MECH)	5098JJ2002H	5098JJ2002H	5098JJ2002H
146C	CONNECTOR ASSEMBLY (MECH)	5098JJ2002G	5098JJ2002G	5098JJ2002G
147A	BANK,DAIRY	5074JJ1005A	5074JJ1005A	5074JJ1005A
147B	TRAY,EGG	3390JJ1014A	3390JJ1014A	3390JJ1014A
147C	COVER,BANK	3550JJ1017A	3550JJ1017A	3550JJ1017A
147D	TRAY,BUTTER	3390JJ2003A	3390JJ2003A	3390JJ2003A
149C	SHELF ASSEMBLY,R	5027JJ2010B	5027JJ2010B	5027JJ2010B
149E	SHELF ASSEMBLY,R	5027JJ2009B	5027JJ2009B	5027JJ2009B
151A	TRAY ASSEMBLY,VEGETABLE	3391JJ1019E	3391JJ1019E	3391JJ1019E
151C	KNOB,SHUTTER	4940JJ2003B	4940JJ2003B	4940JJ2003B
154A	COVER,T/V	3550JJ1033A	3550JJ1033A	3550JJ1033A
155B	SUPPORTER ASSEMBLY,COVER-T/V	4981JJ2001A	4981JJ2001A	4981JJ2001A
158A	COVER,LAMP	3550JJ1040A	3550JJ1040A	3550JJ1040A
158E	COVER,LAMP	3550JJ1051A	3550JJ1051A	3550JJ1051A
160A	GLASS,SHELF	4890JL1002K	4890JL1002K	4890JL1002K
160B	DECO,TRAY	3806JL2005D	3806JL2005D	3806JL2005D
161A	COVER,TRAY	3550JJ2026A	3550JJ2026A	3550JJ2026A
168A	COVER,MAGIC ROOM	3550JJ1035A	3550JJ1035A	3550JJ1035A
170A	TRAY ASSEMBLY,MEAT	3391JJ2004K	3391JJ2004K	3391JJ2004K
200A	DOOR ASSEMBLY,F	3581JJ8058P	3581JJ8058N	3581JJ8058E
201A	DOOR FOAM ASSEMBLY,F	5433JJ0022W	5433JJ0022U	5433JJ0022M
203A	GASKET ASSEMBLY,DOOR	4987JJ1004A	4987JJ1004A	4987JJ1004E
212A	HANDLE,F	3650JJ1041A	3650JJ1041B	3650JJ1040A
212G	MARK	3846JD1007B	3846JD1007B	3846JD1007B
230A	DOOR ASSEMBLY,R/R	3581JJ8056J	3581JJ8056H	3581JJ8056D
230B	DOOR ASSEMBLY,R/L	3581JJ8057L	3581JJ8057K	3581JJ8055C
231A	DOOR FOAM ASSEMBLY,R	5433JJ0063G	5433JJ0063C	5433JJ0063E
231B	DOOR FOAM ASSEMBLY,R	5433JJ0061M	5433JJ0061L	5433JJ0061C
233A	GASKET ASSEMBLY,DOOR	4987JJ2003E	4987JJ2003E	4987JJ2003F
233B	GASKET ASSEMBLY,DOOR	4987JJ2003G	4987JJ2003G	4987JJ2003H
233C	COVER ASSEMBLY,FRONT	3551JJ2034B	3551JJ2034B	3551JJ2034B
233D	COVER ASSEMBLY,FRONT	3551JJ2034A	3551JJ2034A	3551JJ2034A
241A	COVER,TRAY	3550JL2006A	3550JL2006A	3550JL2006A
241B	BANK,DAIRY	5074JJ1019A	5074JJ1019A	5074JJ1019A
241C	BASKET ASSEMBLY,DOOR	5005JJ2022A	5005JJ2022A	5005JJ2022A
243A	STOPPER,DOOR	4620JJ3006D	4620JJ3006A	4620JJ3006C
243A	STOPPER,DOOR	4620JJ3006D	4620JJ3006A	4620JJ3006C
243B	STOPPER,DOOR	4620JJ2009A	4620JJ2009A	4620JJ2009A
243B	STOPPER,DOOR	4620JJ2009A	4620JJ2009A	4620JJ2009A
244B	HOLDER,HANDLE	4930JJ2018B	4930JJ2018A	4930JJ2018B
244C	HOLDER,HANDLE	4930JJ2017B	4930JJ2017A	4930JJ2017B
244E	HANDLE ASSEMBLY,R	3650JA1221C	3651JA2269D	3650JA2158A
244G	STOPPER,HANDLE	4620JJ3007B	4620JJ3007B	4620JJ3007B
245A	HOLDER,HANDLE	4930JJ2019B	4930JJ2019A	4930JJ2019B

LOC	DESCRIPCION	LRFC22750TT	LRFC22750SW	LRFC22750ST
245B	HOLDER,HANDLE	4930JJ2020B	4930JJ2020A	4930JJ2020B
248A	RAIL ASSEMBLY,SLIDE	5219JJ1002D	5219JJ1002D	5219JJ1002D
248F	SUPPORTER,HOLDER	4980JJ2005A	4980JJ2005A	4980JJ2005A
262D	CLIP	4004JA3002A	4004JA3002A	4004JA3002A
262E	SCREW ASSEMBLY	4001JA3005A	4001JA3005A	4001JA3005A
262H	HINGE ASSEMBLY,C	4775JJ2017R	4775JJ2017D	4775JJ2017H
271A	HINGE ASSEMBLY,U	4775JJ2018B	4775JJ2018B	4775JJ2018B
271C	HINGE ASSEMBLY,U	4775JJ2018A	4775JJ2018A	4775JJ2018A
278C	LEVER,SHUTTER	4510JJ2002A	4510JJ2002A	4510JJ2002A
281A	COVER ASSEMBLY,HINGE	3551JJ1016S	3551JJ1016M	3551JJ1016Q
282B	HINGE ASSEMBLY,C	4775JJ2017P	4775JJ2017B	4775JJ2017F
282E	COVER ASSEMBLY,HINGE	3551JJ1016X	3551JJ1016T	3551JJ1016V
282F	DECO,DUCT	3806JL2006E	3806JL2006E	3806JL2006E
284D	SCREW,DRAWING	1STZJA3004K	1STZJA3004K	1STZJA3004K
285A	GUIDE ASSEMBLY,RAIL	4975JJ2008B	4975JJ2008B	4975JJ2008B
301A	EVAPORATOR ASSEMBLY	5421JJ1001B	5421JJ1001B	5421JJ1001B
304A	COVER ASSEMBLY,BACK-M/C	3551JJ2008B	3551JJ2008B	3551JJ2008B
305B	ROLLER	4580JJ3001A	4580JJ3001A	4580JJ3001A
305B	ROLLER	4580JJ3001A	4580JJ3001A	4580JJ3001A
305C	PIN,DRAWING	4J04238A	4J04238A	4J04238A
305C	PIN,DRAWING	4J04238A	4J04238A	4J04238A
307A	COMPRESSOR,SET ASSEMBLY	2521C-A5729	2521C-A5729	2521C-A5729
308A	P.T.C ASSEMBLY	6748C-0004D	6748C-0004D	6748C-0004D
309A	O.L.P	6750C-0005P	6750C-0005P	6750C-0005P
310A	COVER,P.T.C	3550JA2042A	3550JA2042A	3550JA2042A
312A	RUBBER,SEAT	5040JA3031A	5040JA3031A	5040JA3031A
314A	STOPPER,COMP	4620JA3009A	4620JA3009A	4620JA3009A
315A	COMP BASE ASSEMBLY,STD	3103JJ1001J	3103JJ1001J	3103JJ1001J
317A	DRIER ASSEMBLY	5851JJ2002B	5851JJ2002B	5851JJ2002B
318A	HOLDER,DRIER	4930JJ3002A	4930JJ3002A	4930JJ3002A
319A	TRAY,DRIP	3390JJ0004A	3390JJ0004A	3390JJ0004A
319C	GUIDE,FAN	4974JJ1009A	4974JJ1009A	4974JJ1009A
319E	BRACKET,MOTOR	4810JJ2005A	4810JJ2005A	4810JJ2005A
323B	CONDENSER ASSEMBLY,WIRE	5403JJ1007A	5403JJ1007A	5403JJ1007A
327A	CAP,DRAIN PIPE	5006JA3034A	5006JA3034A	5006JA3034A
328B	RUBBER,DAMPING	4J04328A	4J04328A	4J04328A
328B	RUBBER,DAMPING	4J04328A	4J04328A	4J04328A
329A	FAN ASSEMBLY	5901JJ1005A	5901JJ1005A	5901JJ1005A
329C	FAN ASSEMBLY	5901JJ1004B	5901JJ1004B	5901JJ1004B
332A	GRILLE ASSEMBLY,FAN	3531JJ1004A	3531JJ1004A	3531JJ1004A
401A	CONTROLLER ASSEMBLY(CIRC)	6615JB2005C	6615JB2005C	6615JB2005C
402A	SWITCH,[PUSH]	6600JB3007B	6600JB3007A	6600JB3007E
402A	SWITCH,[PUSH]	6600JB3007B	6600JB3007A	6600JB3007E
404A	MOTOR ASSEMBLY,REF FAN	4681JK1004A	4681JK1004A	4681JK1004A
405A	BRACKET ASSEMBLY,MOTOR	4811JJ2002A	4811JJ2002A	4811JJ2002A
405B	RUBBER,MOTOR-N	5040JJ2001A	5040JJ2001A	5040JJ2001A
405C	RUBBER,MOTOR-F	5040JA2009B	5040JA2009B	5040JA2009B

LOC	DESCRIPCION	LRFC22750TT	LRFC22750SW	LRFC22750ST
405F	RUBBER,MOTOR-F	5040JA2004B	5040JA2004B	5040JA2004B
405G	BRACKET ASSEMBLY,MOTOR	4811JJ2002H	4811JJ2002H	4811JJ2002H
406B	SWITCH,[PUSH]	6600JB1004A	6600JB1004A	6600JB1004A
409B	LAMP,[INCANDESCENT]	6912JK2002C	6912JK2002C	6912JK2002C
409D	REFLECTOR,LAMP	3034JJ1002B	3034JJ1002B	3034JJ1002B
410A	SOCKET ASSEMBLY,LAMP	6621JK2002D	6621JK2002D	6621JK2002D
410G	CAPACITOR,DRAWING	0CZZJB2012G	0CZZJB2012G	0CZZJB2012G
411A	POWER CORD ASSEMBLY	6411JK1006H	6411JK1006H	6411JK1006H
418A	HEATER,SHEATH	5300JB1100J	5300JB1100J	5300JB1100J
420A	MOTOR ASSEMBLY,REF FAN	4681JK1004C	4681JK1004C	4681JK1004C
501A	PWB(PCB) ASSEMBLY,MAIN	6871JB1375A	6871JB1375A	6871JB1375A
501F	COVER,PWB	3550JJ1042B	3550JJ1042B	3550JJ1042B
503C	PWB(PCB) ASSEMBLY,DISPLAY	6871JB1374A	6871JB1374A	6871JB1374A
503D	CASE,DISPLAY	3110JJ1005A	3110JJ1005A	3110JJ1005A
503E	COVER,DISPLAY	3550JJ2032A	3550JJ2032A	3550JJ2032A
503G	DECO,CONTROL	3806JL1035A	3806JL1035A	3806JL1035A
600A	ICE MAKER ASSEMBLY,KIT	5989JA0002A	5989JA0002A	5989JA0002A
602A	HOLDER,BRACKET	4930JA3037A	4930JA3037A	4930JA3037A
610A	COVER,SENSOR	3550JJ2020A	3550JJ2020A	3550JJ2020A
616E	TUBE,PE	5210JA3005N	5210JA3005N	5210JA3005N
618A	TUBE,INJECT	5210JJ3005B	5210JJ3005B	5210JJ3005B
619A	VALVE,WATER	5220JA2009D	5220JA2009D	5220JA2009D
619B	COVER,VALVE	3550JJ2024A	3550JJ2024A	3550JJ2024A
619C	VALVE ASSEMBLY,WATER	5221JA2008G	5221JA2008G	5221JA2008G
621A	CONNECTOR (MECH),DOOR	4932JJ2001B	4932JJ2001B	4932JJ2001B
622A	TUBE,INLET	5210JJ3002A	5210JJ3002A	5210JJ3002A
623C	BAND (MECH)	4770JA3001A	4770JA3001A	4770JA3001A
700B	HANDLE ASSEMBLY,F	3651JJ2010N	3651JJ2010P	3651JA2268H
700C	HANDLE ASSEMBLY,R	3651JA2269C	3651JA2269D	3651JA2269G
903A	COVER,LOWER	3550JJ0006D	3550JJ0006A	3550JJ0006C
903B	HOLDER,COVER LOWER	4930JJ2021A	4930JJ2021A	4930JJ2021A
903D	SENSOR	6500JK1003A	6500JK1003A	6500JK1003A
903E	SENSOR	6500JK1004A	6500JK1004A	6500JK1004A
S01	SCREW,DRAWING	1SZZJJ3010A	1SZZJJ3010A	1SZZJJ3010A
S22	SCREW,DRAWING	3J05696C	3J05696C	3J05696C
S24	SCREW,DRAWING	1SZZJA3011B	1SZZJA3011B	1SZZJA3011B
S28	SCREW,DRAWING	3J05696W	3J05696W	3J05696W



P/No. 3828JL8076B

May 13, 2005