

H11G1, H11G2, H11G3  
H11G1X



**ISOCOM**  
COMPONENTS



**HIGH VOLTAGE DARLINGTON  
OUTPUT OPTICALLY COUPLED  
ISOLATOR**

**APPROVALS**

- UL recognised, File No. E91231  
Package Code " JJ "
- 'X' SPECIFICATION APPROVALS
  - H11G1X VDE0884 in 3 available lead form:-
    - STD
    - G form
    - SMD approved to CECC 00802

**DESCRIPTION**

The H11G\_ series are optically coupled isolators consisting of an infrared light emitting diode and a high voltage NPN silicon photo darlington which has an integral base-emitter resistor to optimise switching speed and elevated temperature characteristics in a standard 6pin dual in line plastic package.

**FEATURES**

- Options :-  
10mm lead spread - add G after part no.  
Surface mount - add SM after part no.  
Tape&reel - add SMT&R after part no.
- High Isolation Voltage (5.3kV<sub>RMS</sub>, 7.5kV<sub>PK</sub>)
- High Current Transfer Ratio (1000% min)
- High BV<sub>CEO</sub> (H11G1 - 100V min.)
- Low collector dark current :-  
100nA max. at 80V V<sub>CE</sub>
- Low input current 1mA I<sub>F</sub>

**APPLICATIONS**

- Modems
- Copiers, facsimiles
- Numerical control machines
- Signal transmission between systems of different potentials and impedances

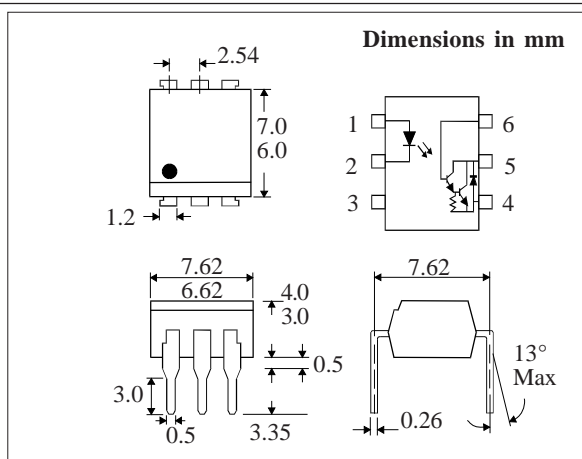
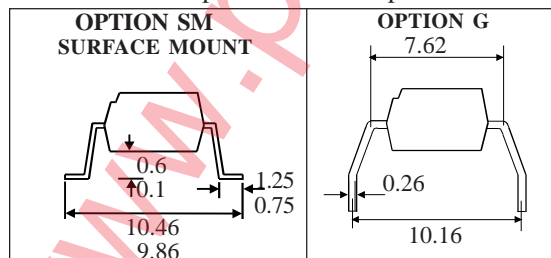

**ABSOLUTE MAXIMUM RATINGS  
(25°C unless otherwise specified)**

Storage Temperature \_\_\_\_\_ -40°C to +125°C  
Operating Temperature \_\_\_\_\_ -25°C to +100°C  
Lead Soldering Temperature  
(1/16 inch (1.6mm) from case for 10 secs) 260°C

**INPUT DIODE**

Forward Current \_\_\_\_\_ 50mA  
Reverse Voltage \_\_\_\_\_ 6V  
Power Dissipation \_\_\_\_\_ 70mW

**OUTPUT TRANSISTOR**

Collector-emitter Voltage BV<sub>CEO</sub>  
H11G3, H11G2, H11G1 \_\_\_\_\_ 55, 80, 100V  
Collector-base Voltage BV<sub>CBO</sub>  
H11G3, H11G2, H11G1 \_\_\_\_\_ 55, 80, 100V  
Emitter-base Voltage BV<sub>EBO</sub> \_\_\_\_\_ 6V  
Collector Current \_\_\_\_\_ 150mA  
Power Dissipation \_\_\_\_\_ 300mW

**POWER DISSIPATION**

Total Power Dissipation \_\_\_\_\_ 350mW

**ISOCOM COMPONENTS 2004 LTD**

Unit 25B, Park View Road West,  
Park View Industrial Estate, Brenda Road  
Hartlepool, TS25 1UD England  
Tel: (01429)863609 Fax : (01429) 863581 e-mail  
sales@isocom.co.uk http://www.isocom.com

**ELECTRICAL CHARACTERISTICS (  $T_A = 25^\circ\text{C}$  Unless otherwise noted )**

PARAMETER		MIN	TYP	MAX	UNITS	TEST CONDITION
Input	Forward Voltage ( $V_F$ )		1.2	1.5	V	$I_F = 10\text{mA}$
	Reverse Current ( $I_R$ )			10	$\mu\text{A}$	$V_R = 4\text{V}$
Output	Collector-emitter Breakdown ( $BV_{CEO}$ )				V	$I_C = 1\text{mA}$
	H11G1	100			V	$I_C = 1\text{mA}$
	H11G2	80			V	$I_C = 1\text{mA}$
	H11G3	55			V	$I_C = 1\text{mA}$
	Collector-base Breakdown ( $BV_{CBO}$ )				V	$I_C = 100\mu\text{A}$
	H11G1	100			V	$I_C = 100\mu\text{A}$
	H11G2	80			V	$I_C = 100\mu\text{A}$
	H11G3	55			V	$I_C = 100\mu\text{A}$
	Emitter-base Breakdown ( $BV_{EBO}$ )	6			V	$I_E = 0.1\text{mA}$
	Collector-emitter Dark Current ( $I_{CEO}$ )				nA	$V_{CE} = 80\text{V}$
H11G1			100	nA	$V_{CE} = 60\text{V}$	
H11G2			100	nA	$V_{CE} = 30\text{V}$	
H11G3			100	nA		
Coupled	Collector Output Current ( $I_C$ )				mA	$10\text{mA } I_F, 1.2\text{V } V_{CE}$
	H11G1, H11G2	100			mA	$1\text{mA } I_F, 5\text{V } V_{CE}$
	H11G1, H11G2	5			mA	$1\text{mA } I_F, 5\text{V } V_{CE}$
	H11G3	2			mA	
	Collector-emitter Saturation Voltage $V_{CE(SAT)}$				V	$1\text{mA } I_F, 1\text{mA } I_C$
	H11G1, H11G2			1.0	V	$16\text{mA } I_F, 50\text{mA } I_C$
	H11G1, H11G2			1.2	V	$20\text{mA } I_F, 50\text{mA } I_C$
	H11G3			1.2	V	See note 1
	Input to Output Isolation Voltage $V_{ISO}$	5300			$V_{RMS}$	See note 1
		7500			$V_{PK}$	$V_{IO} = 500\text{V}$ (note 1)
	Input-output Isolation Resistance $R_{ISO}$	$5 \times 10^{10}$	$10^{11}$		$\Omega$	$V = 0, f = 1\text{MHz}$
Input-output Capacitance $C_f$		0.6		pF		
Response time (Rise), tr		100		$\mu\text{s}$	$I_C = 20\text{mA}, V_{CE} = 2\text{V}, R_L = 100\Omega$	
Response time (Fall), tf		20		$\mu\text{s}$		

Note 1 Measured with input leads shorted together and output leads shorted together.

Note 2 Special Selections are available on request. Please consult the factory.

**FIGURE 1**

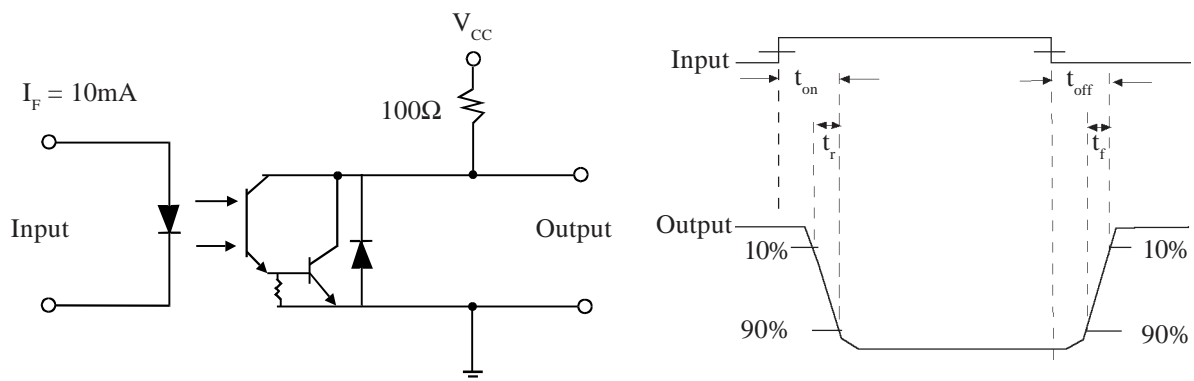

**Collector Power Dissipation vs. Ambient Temperature**

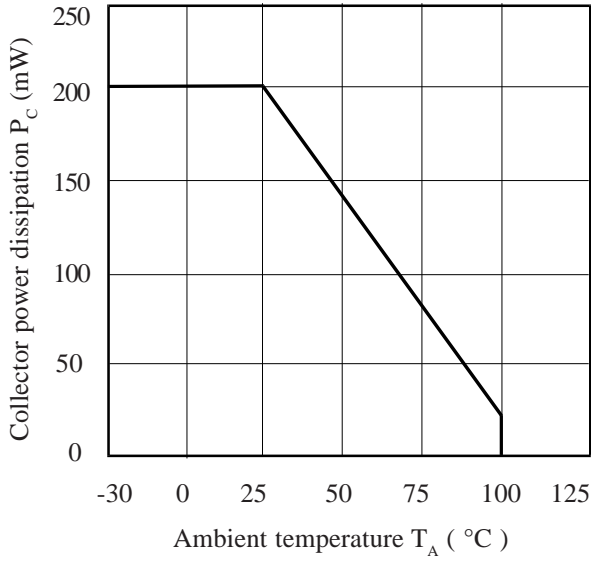

**Normalized Output Current vs. Collector-emitter Voltage**

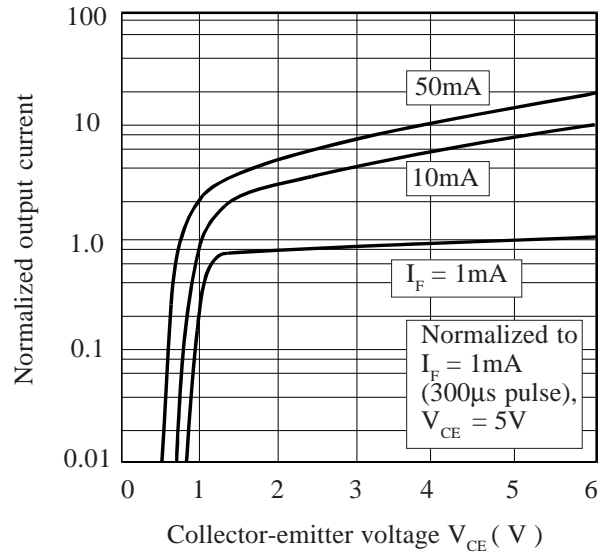

**Forward Current vs. Ambient Temperature**

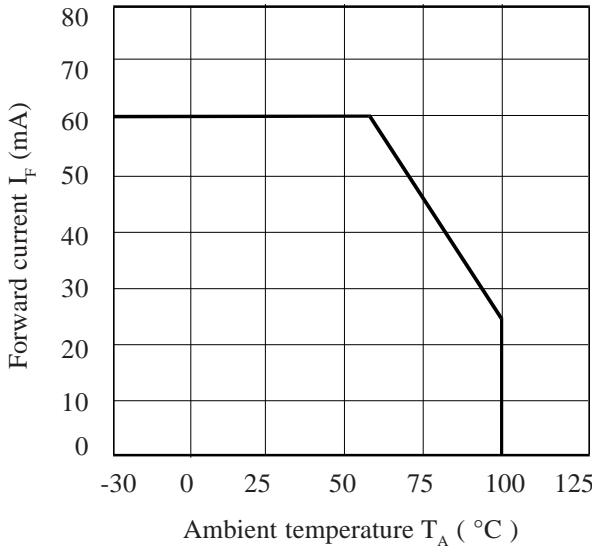

**Normalized Output Current vs. Ambient Temperature**

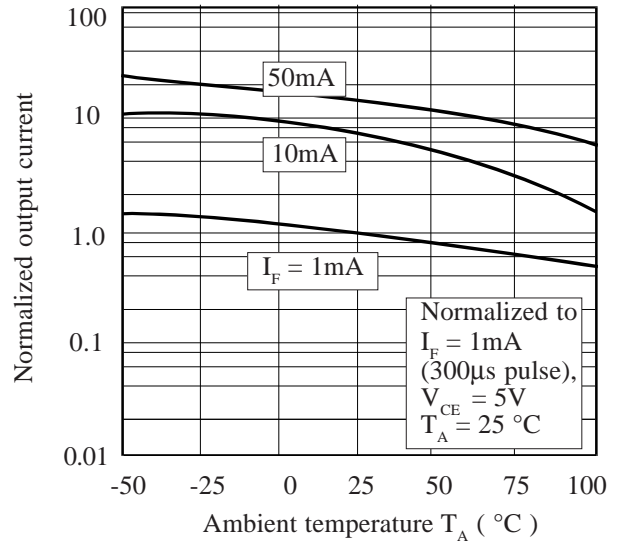

**Normalized Output Current vs. Input Current**

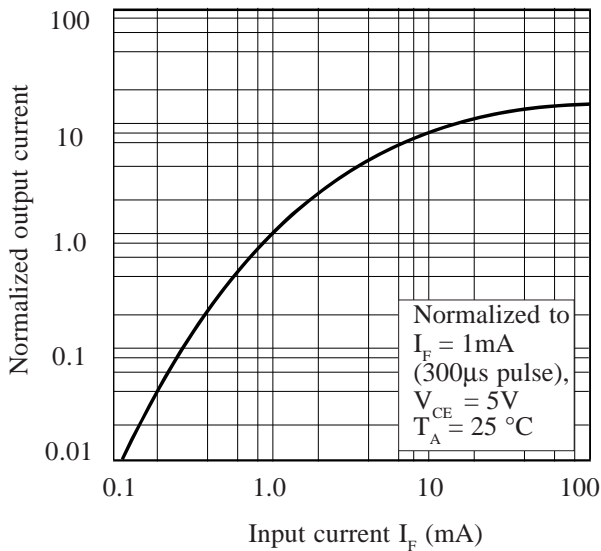

**Collector Dark Current vs. Ambient Temperature**

