

- Page 31 Completed Part Number
- (See Table) Insert Arrangements
- Pages 10–11 Electrical Performance
- Page 9 Mechanical and Environmental Performance
- Pages 10–11 Filter Selection

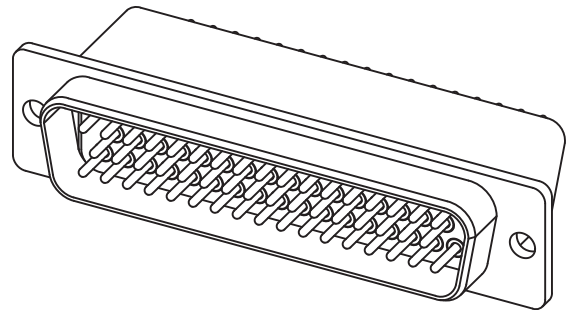

Shell Size	Standard Layout #20 Contact	High Density Layout #22D Contact	A		B		B		C		D		D		E		F		G	
			±.015	±.38	for pin		for socket		±.005 ±.13		for pin		for socket		±.015	±.38	±.010	±.25	±.010	±.25
			inch	mm	inch	mm	inch	mm	inch	mm	inch	mm	inch	mm	inch	mm	inch	mm	inch	mm
1	9	15	1.213	30.81	.666	16.92	.643	16.33	.984	24.99	.329	8.36	.309	7.85	.494	12.55	.759	19.28	.422	10.72
2	15	26	1.541	39.14	.994	25.25	.971	24.66	1.312	33.32	.329	8.36	.309	7.85	.494	12.55	1.083	27.51	.422	10.72
3	25	44	2.088	53.04	1.534	38.96	1.511	38.38	1.852	47.04	.329	8.36	.309	7.85	.494	12.55	1.625	41.28	.422	10.72
4	37	62	2.729	69.32	2.182	55.42	2.159	54.84	2.500	63.50	.329	8.36	.309	7.85	.494	12.55	2.272	57.71	.422	10.72
5	50	78	2.635	66.93	2.079	52.81	2.064	52.43	2.406	61.11	.441	11.20	.423	10.74	.605	15.37	2.178	55.32	.534	13.56
6	-	104	2.729	69.32	2.212	56.18	2.189	55.60	2.500	63.50	.503	12.78	.485	12.32	.668	16.97	2.302	58.47	.596	15.14

**MIL-DTL-24308 D-Sub  
J085P/R  
Mounting Dimensions**

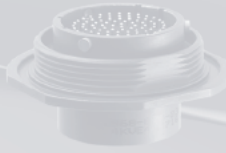

**D-Subminiature Connectors**

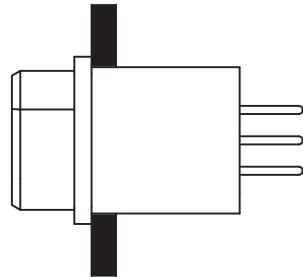

**FRONT MOUNTING**

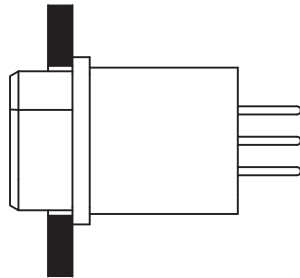

**REAR MOUNTING**

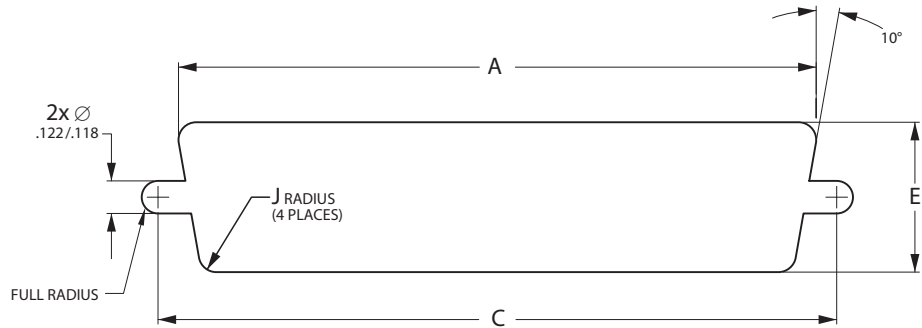

**STANDARD CUTOUT (Front or Rear Mount)**

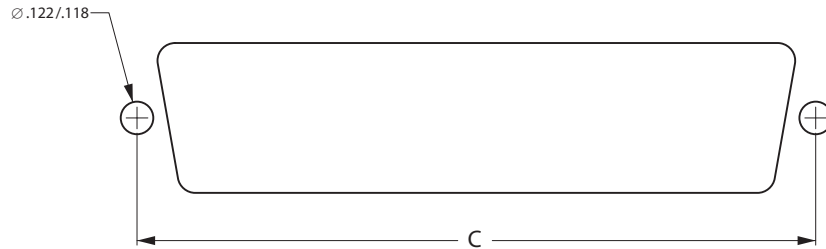

**OPTIONAL CUTOUT (for Rear Mounting)**

Shell Size	A		A		C		C		E		E		J		J	
	Front Mount		Rear Mount		Front Mount		Rear Mount		Front Mount		Rear Mount		Front Mount		Rear Mount	
	±.005 inch	±.13 mm	±.005 inch	±.13 mm	±.005 inch	±.13 mm	±.005 inch	±.13 mm	±.005 inch	±.13 mm	±.005 inch	±.13 mm	±.005 inch	±.13 mm	±.005 inch	±.13 mm
1	.833	21.16	.806	20.47	.984	24.99	.984	24.99	.485	12.32	.449	11.40	.065	1.65	.132	3.35
2	1.161	29.49	1.134	28.80	1.312	33.32	1.312	33.32	.485	12.32	.449	11.40	.065	1.65	.132	3.35
3	1.700	43.18	1.674	42.52	1.852	47.04	1.852	47.04	.485	12.32	.449	11.40	.065	1.65	.132	3.35
4	2.349	59.66	2.326	59.08	2.500	63.50	2.500	63.50	.485	12.32	.449	11.40	.065	1.65	.132	3.35
5	2.254	57.25	2.218	56.34	2.406	61.11	2.406	61.11	.593	15.06	.555	14.10	.065	1.65	.132	3.35
6	2.372	60.25	2.250	57.15	2.500	63.50	2.500	63.50	.655	16.64	.617	15.67	.065	1.65	.132	3.35



## Right Angle Printed Circuit Termination

A popular variation of the D-Sub family is the right angle contact termination. Jerrick can provide the 90° contact bending for signal and some power pins (non standard arrangements). We also supply two configurations of shells, shown here in both 2 row and 3 row versions. While the original design relies on the contacts soldered to the board to support the assembly, the customer can use the newer board mount style for added mechanical integrity in vibration.

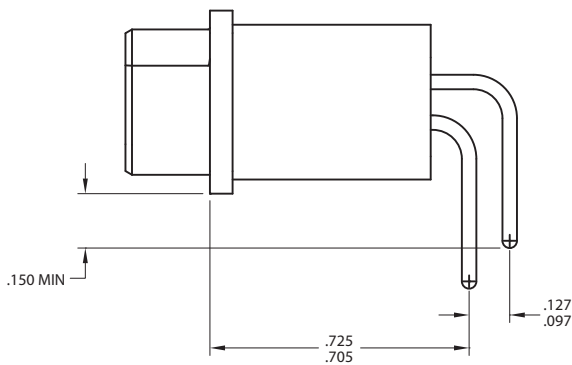

2 ROW CONFIGURATION (9, 15, 25, 37 Contact Arrangements)

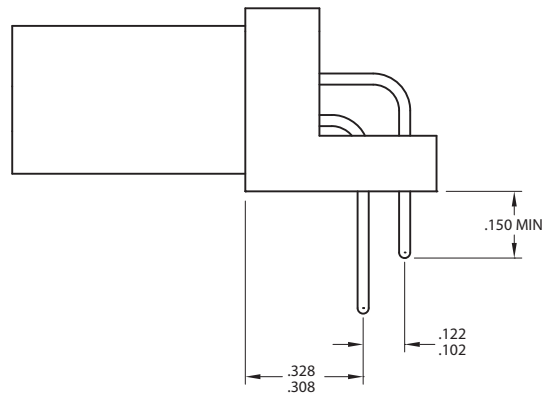

2 ROW BOARD-MOUNT CONFIGURATION

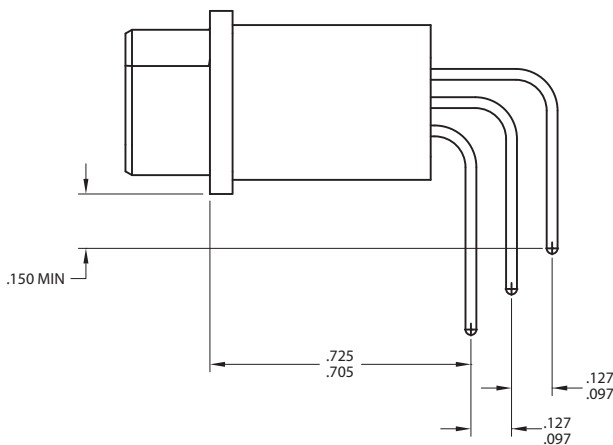

3 ROW CONFIGURATION (50 Contact Arrangements)

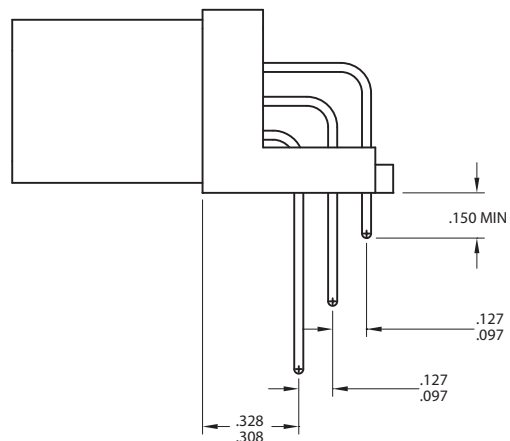

3 ROW BOARD-MOUNT CONFIGURATION