

This datasheet describes the use of the MiCS-5914. The package and the mode of operation illustrated in this document target the detection of ammonia (NH<sub>3</sub>).

### FEATURES

- Low heater current
- Wide detection range
- Wide temperature range
- High sensitivity
- Miniature dimensions
- High resistance to shocks and vibrations

### OPERATING MODE

The recommended mode of operation is constant power. The nominal power is  $P_H = 66 \text{ mW}$ . The resulting temperature of the sensing layer is about 320 °C, in air at approximately 20 °C.

Detection of the pollution gases is achieved by measuring the sensing resistance of the sensor. The resistance decreases in the presence of NH<sub>3</sub>.

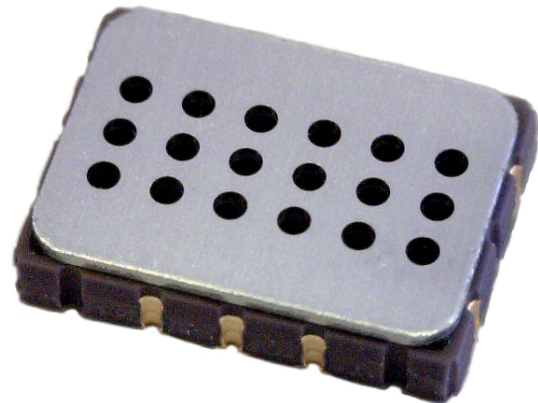

### SENSOR CONFIGURATION

The silicon gas sensor structure consists of an accurately micro machined diaphragm with an embedded heating resistor and the sensing layer on top.

The internal connections are shown below.

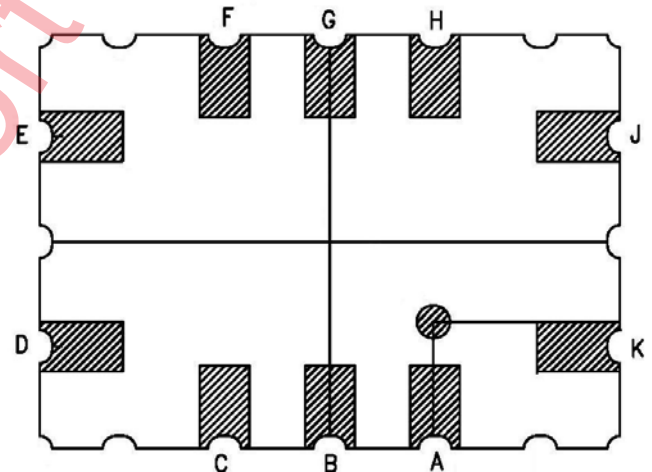

| Pin | Connection |
|-----|------------|
| A   |            |
| B   |            |
| C   | Rh1        |
| D   | Rs1        |
| E   |            |
| F   | Rh2        |
| G   | Rs2        |
| H   |            |
| J   |            |
| K   |            |

Rs: sensor resistance  
Rh: heater resistance

Figure 1: MiCS-5914 configuration (bottom view)

Whilst e2v technologies has taken care to ensure the accuracy of the information contained herein it accepts no responsibility for the consequences of any use thereof and also reserves the right to change the specification of goods without notice. e2v technologies accepts no liability beyond the set out in its standard conditions of sale in respect of infringement of third party patents arising from the use of tubes or other devices in accordance with information contained herein.

e2v technologies (uk) limited, Waterhouse Lane, Chelmsford, Essex CM1 2QU United Kingdom Telephone: +44 (0)1245 493493 Facsimile: +44 (0)1245 492492

e-mail: [enquiries@e2v.com](mailto:enquiries@e2v.com) Internet: [www.e2v.com](http://www.e2v.com) Holding Company: e2v technologies plc

e2v technologies inc. 520 White Plains Road, Suite 450, Tarrytown, NY10591 USA Telephone: (914) 592-6050 Facsimile: (914) 592-5148 e-mail: [enquiries@e2vtechnologies.us](mailto:enquiries@e2vtechnologies.us)

## POWER CIRCUIT EXAMPLE

As shown below, one external load resistor can be used to power the heater with a single 5 V power supply.

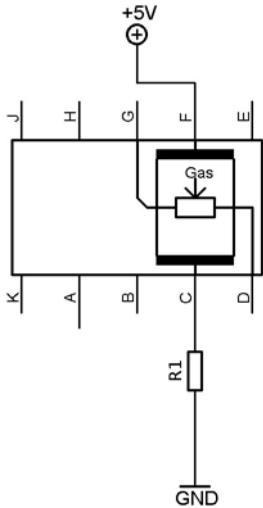
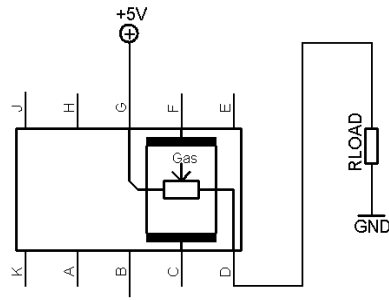

**Figure 2: MiCS-5914 with recommended supply circuit (top view)**

R1 is typically a E96 resistor at 93.1  $\Omega$ . This resistor is necessary to obtain the right temperature on the heater while using a single 5 V power supply. The resulting voltage is typically  $V_H = 2.2$  V.

## MEASUREMENT CIRCUIT EXAMPLE

As shown below, the sensitive resistance shall be read by using a load resistor.



**Figure 3: MiCS-5914 with measurement circuit (top view)**

The voltage measured on the load resistor is directly linked to the resistance of the sensor. RLOAD must be 820  $\Omega$  at the lowest in order not to damage the sensitive layer.

## SENSOR CHARACTERISTICS

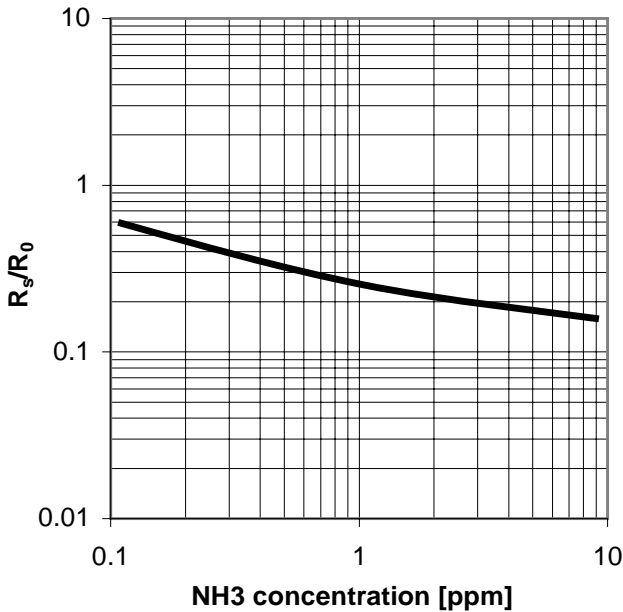

**Figure 4:  $R_s/R_0$  as a function of NH3 concentration at 40% RH and 25 °C, measured on an engineering test bench**

## ELECTRICAL CHARACTERISTICS

| Rating                                    | Symbol       | Value/Range | Unit |
|---|--------------|-------------|------|
| Maximum heater power dissipation          | $P_H$        | 88          | mW   |
| Maximum sensitive layer power dissipation | $P_S$        | 8           | mW   |
| Voltage supply                            | $V_{supply}$ | 4.9 / 5.1   | V    |
| Relative humidity range                   | $R_H$        | 5 / 95      | %RH  |
| Ambient operating temperature             | $T_{amb}$    | -30 / 85    | °C   |
| Storage temperature range                 | $T_{sto}$    | -40 / 120   | °C   |
| Storage humidity range                    | $RH_{sto}$   | 5 / 95      | %RH  |

## OPERATING CONDITIONS

| Parameter                           | Symbol | Typ | Min | Max | Unit     |
|-------------------------------------|--------|-----|-----|-----|----------|
| Heating power                       | $P_H$  | 66  | 60  | 73  | mW       |
| Heating voltage                     | $V_H$  | 2.2 | -   | -   | V        |
| Heating current                     | $I_H$  | 30  | -   | -   | mA       |
| Heating resistance at nominal power | $R_H$  | 72  | 64  | 80  | $\Omega$ |

## SENSITIVITY CHARACTERISTICS

| Characteristic                         | Symbol | Typ | Min | Max  | Unit      |
|--|--------|-----|-----|------|-----------|
| NH3 detection range                    | FS     |     | 0.1 | 100  | ppm       |
| Sensing resistance in air (see note 1) | $R_0$  | -   | 10  | 1500 | $k\Omega$ |
| Sensitivity NH3 1 ppm (see note 2)     | $S_1$  | -   | 1.5 | 15   | -         |

### Notes:

1. Sensing resistance in air  $R_0$  is measured under controlled ambient conditions, i.e. synthetic air at  $23 \pm 5$  °C and  $50 \pm 10\%$ . Sampling test.
2. Sensitivity NH3 1 ppm is defined as  $R_S$  in air ( $R_0$ ) divided by  $R_S$  at 1 ppm NH3. Test conditions are  $23 \pm 5$  °C and  $50 \pm 10\%$  RH. Indicative values only, sampling test.

## IMPORTANT PRECAUTIONS

Read the following instructions carefully before using the MiCS-5914 described in this document to avoid erroneous readings and to prevent the device from permanent damage.

- The sensor must be reflow soldered in a neutral atmosphere, without soldering flux vapours.
- The sensor must not be exposed to high concentrations of organic solvents, silicone vapour or cigarette-smoke in order to avoid poisoning the sensitive layer.
- Heater voltages above the specified maximum rating will destroy the sensor due to overheating.
- This sensor is to be placed in a filtered package that protects it against water and dust projections.
- e2v strongly recommends using ESD protection equipment to handle the sensor.
- For any additional questions, contact e2v.

## PACKAGE OUTLINE DIMENSIONS

The package is compatible with SMD assembly process.

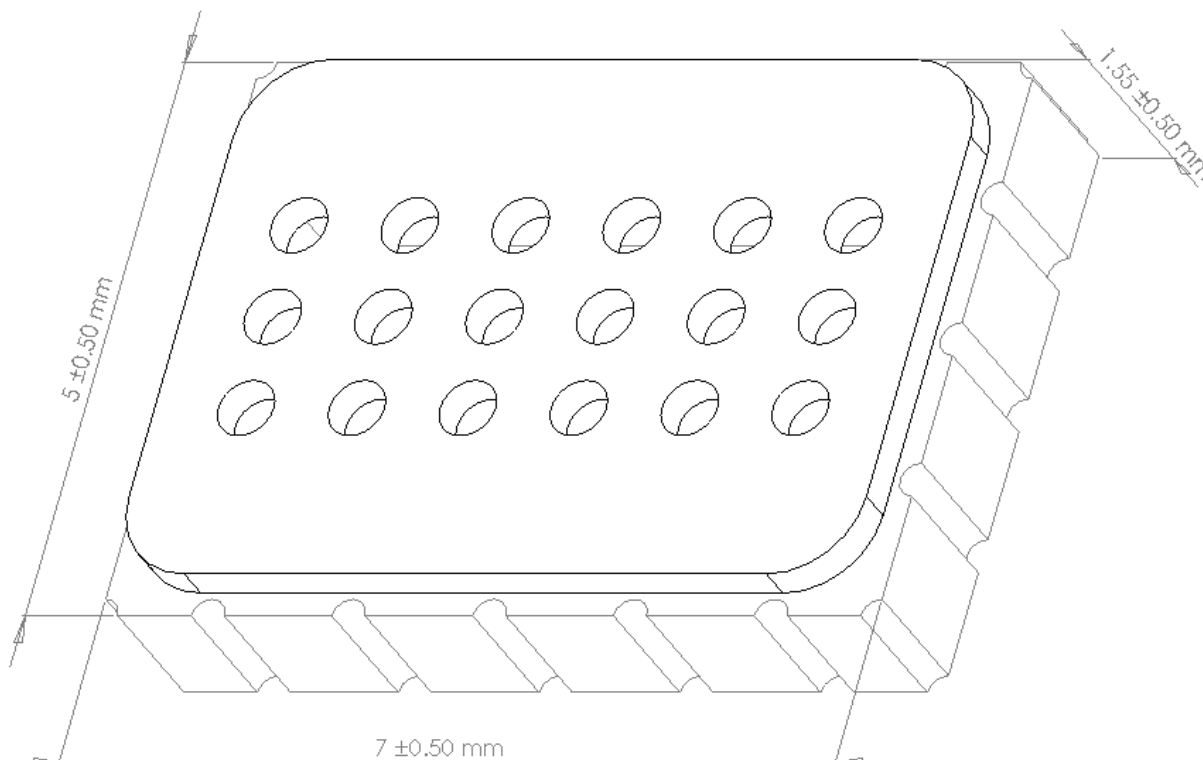

## SOLDERING PADS GEOMETRY

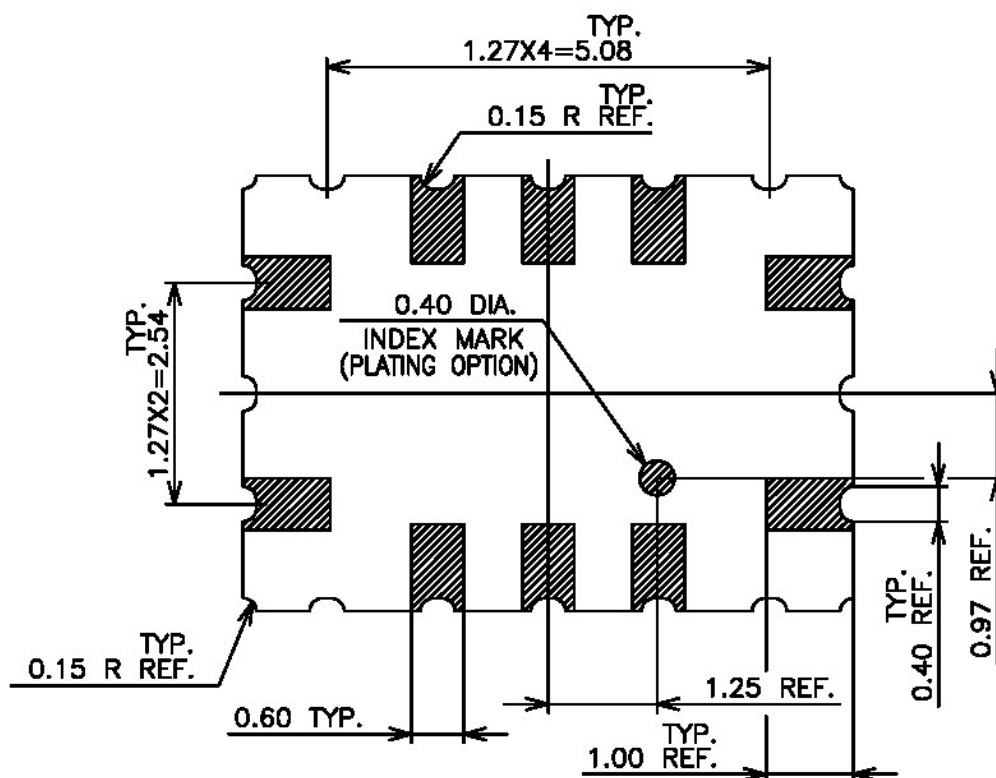

# PACKAGING TAPE AND REEL FOR EXPEDITION

The sensors are placed in a carrier tape. The dimensions of the cavity are 5.5 x 7.5 x 2.55 mm (the tolerance is +/- 0.2 mm).

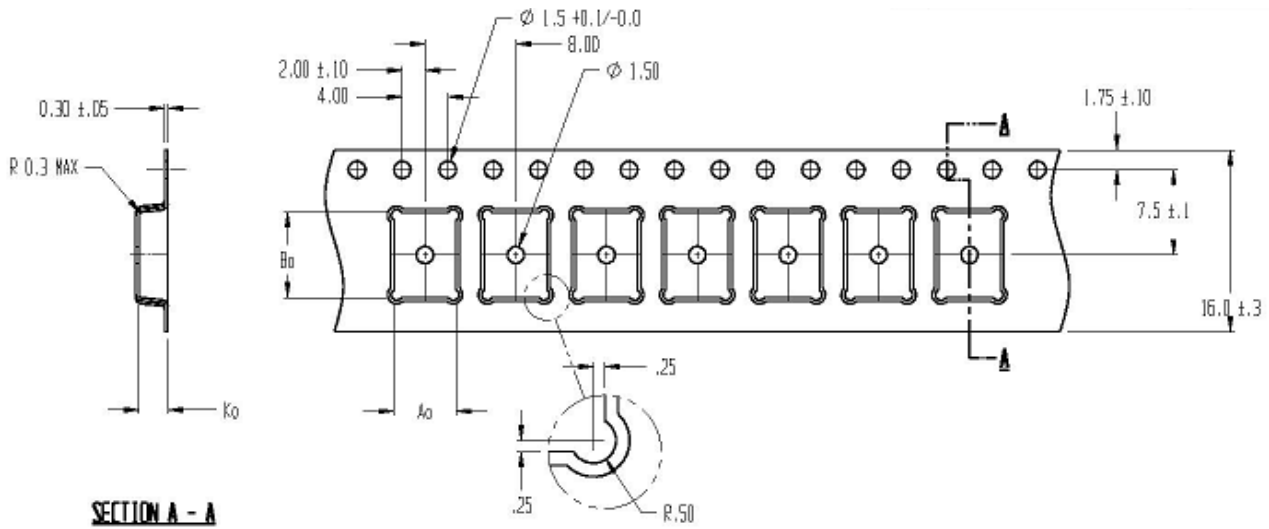

The outside diameter of the reel is either 178 +/- 1 mm (for a maximum of 700 sensors) or 330 +0.25 / -4 mm (for a maximum of 2000 sensors).

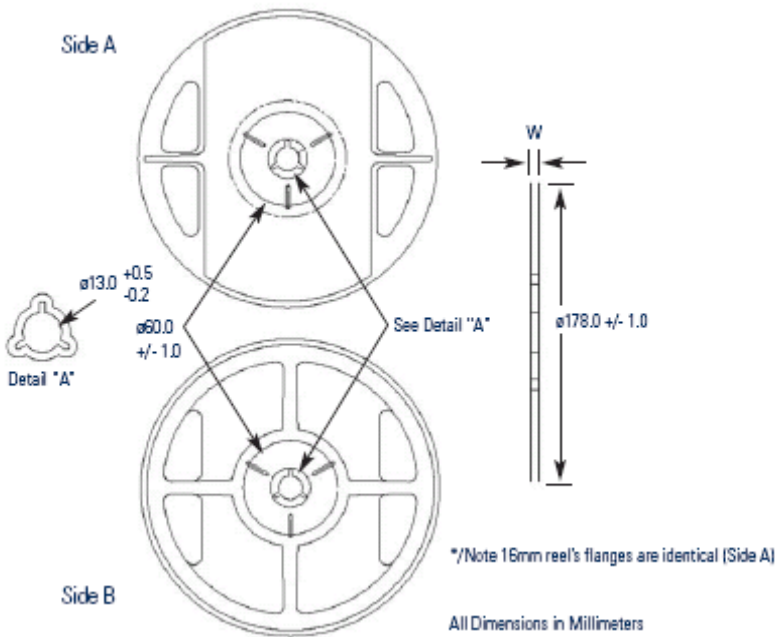

e2v semiconductor gas sensors are well suited for leak detection and applications requiring limited accuracy. Their use for absolute gas concentration detection is more complicated because they typically require temperature compensation, calibration, and sometimes as well, humidity compensation. Their base resistance in clean air and their sensitivity can vary overtime depending on the environment they are in. This effect must be taken into account for any application development (1108-1.0).