

R46 + R Series Metallized Polypropylene Film, Class X2, 275 VAC/300 VAC with Internal Discharge Resistor

Overview

The R46 + R Series is constructed of metallized polypropylene film encapsulated with self-extinguishing resin in a box of material meeting the requirements of UL 94 V-0.

Applications

Typical applications include worldwide use in electromagnetic interference suppression in all X2 and across-the-line applications. Not for use in series with the mains.

Benefits

- Approvals: ENEC, UL, cUL
- Rated voltage: 275/300 VAC 50/60 Hz
- Capacitance range: 0.22 – 10 μ F
- Lead spacing: 22.5 – 37.5 mm
- Capacitance tolerance: \pm 20%, \pm 10%, \pm 5% on request
- Climatic category: 40/110/56, IEC 60068-1
- Tape and reel in accordance with IEC 60286-2
- RoHS Compliant and lead-free terminations
- Operating temperature range of -40°C to +110°C
- 100% screening factory test at 2,200 VDC/1,500 VAC



Part Number System

R46	K	N	3220	00	01	M	E
Series	Rated Voltage (VAC)	Lead Spacing (mm)	Capacitance Code (pF)	Lead and Packaging Code	Internal Use	Capacitance Tolerance	Value of Discharge Resistor
X2, Metallized Polypropylene	K = 275	N = 22.5 R = 27.5 W = 37.5	Digits 2 – 4 indicate the first three digits of the capacitance value. First digit indicates the number of zeros to be added.	See Ordering Options Table	01, M1, M2 (Standard)	J = \pm 5% K = \pm 10% M = \pm 20%	470 k Ω = E 680 k Ω = F 1 M Ω = G 1.2 M Ω = L 1.5 M Ω = N 2.2 M Ω = P 3.3 M Ω = Q 4.7 M Ω = S 6.8 M Ω = T 10 M Ω = V

Ordering Options Table

Lead Spacing Nominal (mm)	Type of Leads and Packaging	Lead Length (mm)	Lead and Packaging Code
22.5	Standard Lead and Packaging Options		
	Bulk (Tray) – Short Leads	4 +2/-0	00
	Tape & Reel (Large Reel)	$H_0 = 18.5 \pm 0.5$	CK
	Other Lead and Packaging Options		
	Bulk (Tray) – Long Leads	25 +2/-1	50
	Bulk (Tray) – Max Length Leads	30 +5/-0	40
	Pizza Pack	4 +2/-0	BB
27.5	Standard Lead and Packaging Options		
	Bulk (Tray) – Short Leads	4 +2/-0	00
	Tape & Reel (Large Reel)	$H_0 = 18.5 \pm 0.5$	CK
	Other Lead and Packaging Options		
	Bulk (Tray) – Long Leads	25 +2/-1	50
	Bulk (Tray) – Max Length Leads	30 +5/-0	40
37.5	Standard Lead and Packaging Options		
	Bulk (Tray) – Short Leads	4 +2/-0	00
	Other Lead and Packaging Options		
	Bulk (Tray) – Long Leads	25 +2/-1	50
	Bulk (Tray) – Max Length Leads	30 +5/-0	40

Dimensions – Millimeters

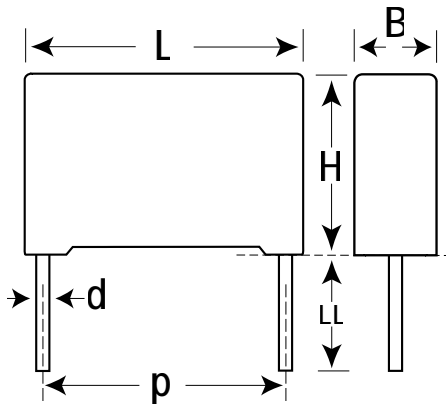

p		B		H		L		d	
Nominal	Tolerance	Nominal	Tolerance	Nominal	Tolerance	Nominal	Tolerance	Nominal	Tolerance
22.5	+/-0.4	7.0	+0.2/-0	16.0	+0.1/-0	26.5	+0.3/-0	0.8	+/-0.05
22.5	+/-0.4	8.5	+0.2/-0	17.0	+0.1/-0	26.5	+0.3/-0	0.8	+/-0.05
22.5	+/-0.4	10.0	+0.2/-0	18.5	+0.1/-0	26.5	+0.3/-0	0.8	+/-0.05
22.5	+/-0.4	11.0	+0.2/-0	20.0	+0.1/-0	26.5	+0.3/-0	0.8	+/-0.05
27.5	+/-0.4	11.0	+0.2/-0	20.0	+0.1/-0	32.0	+0.3/-0	0.8	+/-0.05
27.5	+/-0.4	13.0	+0.2/-0	22.0	+0.1/-0	32.0	+0.3/-0	0.8	+/-0.05
27.5	+/-0.4	14.0	+0.2/-0	28.0	+0.1/-0	32.0	+0.3/-0	0.8	+/-0.05
27.5	+/-0.4	18.0	+0.2/-0	33.0	+0.1/-0	32.0	+0.3/-0	0.8	+/-0.05
27.5	+/-0.4	22.0	+0.2/-0	37.0	+0.1/-0	32.0	+0.3/-0	0.8	+/-0.05
37.5	+/-0.4	11.0	+0.3/-0	22.0	+0.1/-0	41.5	+0.3/-0	1	+/-0.05
37.5	+/-0.4	13.0	+0.3/-0	24.0	+0.1/-0	41.5	+0.3/-0	1	+/-0.05
37.5	+/-0.4	16.0	+0.3/-0	28.5	+0.1/-0	41.5	+0.3/-0	1	+/-0.05
37.5	+/-0.4	19.0	+0.3/-0	32.0	+0.1/-0	41.5	+0.3/-0	1	+/-0.05
37.5	+/-0.4	20.0	+0.3/-0	40.0	+0.1/-0	41.5	+0.3/-0	1	+/-0.05
37.5	+/-0.4	24.0	+0.3/-0	44.0	+0.1/-0	41.5	+0.3/-0	1	+/-0.05

Note: See Ordering Options Table for lead length (LL) options.

Performance Characteristics

Rated Voltage	275 VAC 50/60 Hz	
Capacitance Range	0.22 – 10 μ F	
Capacitance Tolerance	\pm 20%, \pm 10%, \pm 5% on request	
Temperature Range	-40°C to +110°C	
Climatic Category	40/110/56	
Approvals	ENEC, UL, cUL	
Dissipation Factor	Maximum Values at +23°C	
	1 kHz	0.1%
Test Voltage Between Terminals	The 100% screening factory test is carried out at 2,200 VDC/1,500 VAC. The voltage level is selected to meet the requirements in applicable equipment standards. All electrical characteristics are checked after the test. It is not permitted to repeat this test as there is a risk to damage the capacitor. KEMET is not liable in such case for any failures.	
Insulation Resistance	Minimum Values Between Terminals	
	$C \leq 0.33 \mu\text{F}$	$\geq 50,000 \text{ M}\Omega$
	$C > 0.33 \mu\text{F}$	$\geq 30,000 \text{ M}\Omega \cdot \mu\text{F}$
In DC Applications	Recommended voltage \leq 560/630 VDC	

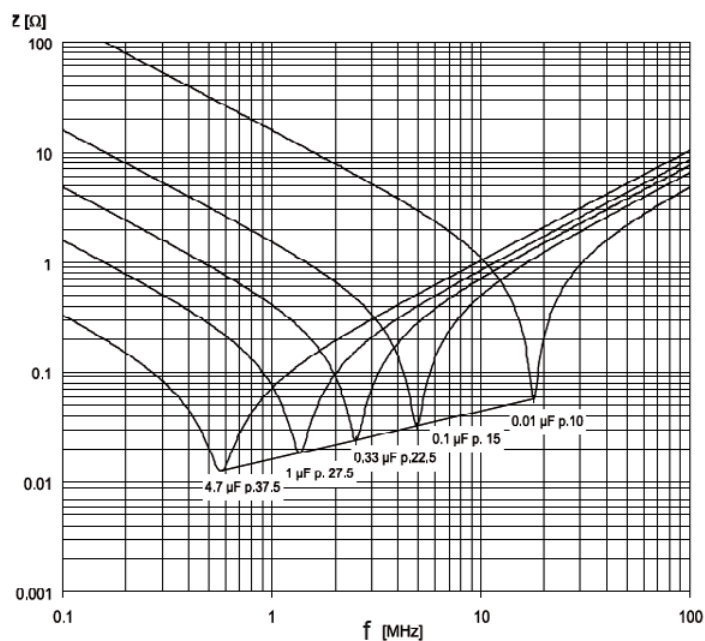

Impedance Graph



Environmental Test Data

Test	IEC Publication	Procedure
Endurance	EN/IEC 60384-14	1.25 x V _R VAC 50 Hz, once every hour increase to 1,000 VAC for 0.1 second, 1,000 hours at upper rated temperature
Vibration	IEC 60068-2-6 Test Fc	3 directions at 2 hours each 10 – 55 Hz at 0.75 mm or 98 m/s ²
Bump	IEC 60068-2-29 Test Eb	1,000 bumps at 390 m/s ²
Change of Temperature	IEC 60068-2-14 Test Na	Upper and lower rated temperature 5 cycles
Active Flammability	IEC 60384-14	V _R + 20 surge pulses at 2.5 kV (pulse every 5 seconds)
Passive Flammability	IEC 60384-14	IEC 60384-1, IEC 60695-11-5 Needle flame test
Damp Heat Steady State	IEC 60068-2-78 Test Cab	+40°C and 93% RH, 56 days

Approvals

Mark	Specification	File Number
	EN/IEC 60384-14	V4413
	UL 1283 (310 VAC)	E85238
	CSA – C22.2 No. 8 (310 VAC)	E85238

Environmental Compliance

All KEMET EMI capacitors are RoHS Compliant.



RoHS Compliant

Table 1 – Ratings & Part Number Reference

Capacitance Value (µF)	Dimensions in mm			Lead Spacing (p)	dV/dt (V/µs)	New KEMET Part Number	Legacy Part Number
	B	H	L				
0.22	7.0	16.0	26.5	22.5	200	46KN3220(1)01(2)(3)	R46KN3220(1)01(2)(3)
0.33	8.5	17.0	26.5	22.5	200	46KN3330(1)01(2)(3)	R46KN3330(1)01(2)(3)
0.47	10.0	18.5	26.5	22.5	200	46KN3470(1)01(2)(3)	R46KN3470(1)01(2)(3)
0.68	11.0	20.0	26.5	22.5	200	46KN3680(1)01(2)(3)	R46KN3680(1)01(2)(3)
0.47	11.0	20.0	32.0	27.5	150	46KR3470(1)01(2)(3)	R46KR3470(1)01(2)(3)
0.68	11.0	20.0	32.0	27.5	150	46KR3680(1)M1(2)(3)	R46KR3680(1)M1(2)(3)
1.0	13.0	22.0	32.0	27.5	150	46KR4100(1)M1(2)(3)	R46KR4100(1)M1(2)(3)
1.5	13.0	22.0	32.0	27.5	150	46KR4150(1)M1(2)(3)	R46KR4150(1)M1(2)(3)
2.2	14.0	28.0	32.0	27.5	150	46KR4220(1)M1(2)(3)	R46KR4220(1)M1(2)(3)
3.3	18.0	33.0	32.0	27.5	150	46KR4330(1)M2(2)(3)	R46KR4330(1)M2(2)(3)
4.7	22.0	37.0	32.0	27.5	150	46KR4470(1)M1(2)(3)	R46KR4470(1)M1(2)(3)
1.5	11.0	22.0	41.5	37.5	100	46KW4150(1)M1(2)(3)	R46KW4150(1)M1(2)(3)
2.2	13.0	24.0	41.5	37.5	100	46KW4220(1)M1(2)(3)	R46KW4220(1)M1(2)(3)
3.3	16.0	28.5	41.5	37.5	100	46KW4330(1)M1(2)(3)	R46KW4330(1)M1(2)(3)
4.7	19.0	32.0	41.5	37.5	100	46KW4470(1)M1(2)(3)	R46KW4470(1)M1(2)(3)
6.8	20.0	40.0	41.5	37.5	100	46KW4680(1)M2(2)(3)	R46KW4680(1)M2(2)(3)
10.0	24.0	44.0	41.5	37.5	100	46KW5100(1)M1(2)(3)	R46KW5100(1)M1(2)(3)
Capacitance Value (µF)	B (mm)	H (mm)	L (mm)	Lead Spacing (p)	dV/dt (V/µs)	New KEMET Part Number	Legacy Part Number

(1) Insert ordering code for lead type and packaging. See Ordering Options Table for available options.

(2) M = ±20%, K = ±10%, J = ±5% on request.

(3) Insert code for Discharge resistor. See Part Number System.

Soldering Process

The implementation of the RoHS Directive has required the use of SnAuCu (SAC) or SnCu alloys as primary solder. These alloys require a higher liquidus temperature (217°C – 221°C) as compared to SnPb eutectic alloy (183°C). Due to the higher pre-heat and wave temperatures, the heat stress to components has increased considerably. Polypropylene capacitors are especially sensitive to soldering temperature due to the relatively low melting point of polypropylene material (160°C – 170°C). As a result, wave soldering can be destructive, especially to mechanically small polypropylene capacitors with lead spacings of 5 – 10 mm. For more information, please refer to KEMET’s Recommended Soldering Profiles or contact a KEMET representative. IEC Publication 61760–1 Edition 2 may also be consulted for general guidelines.

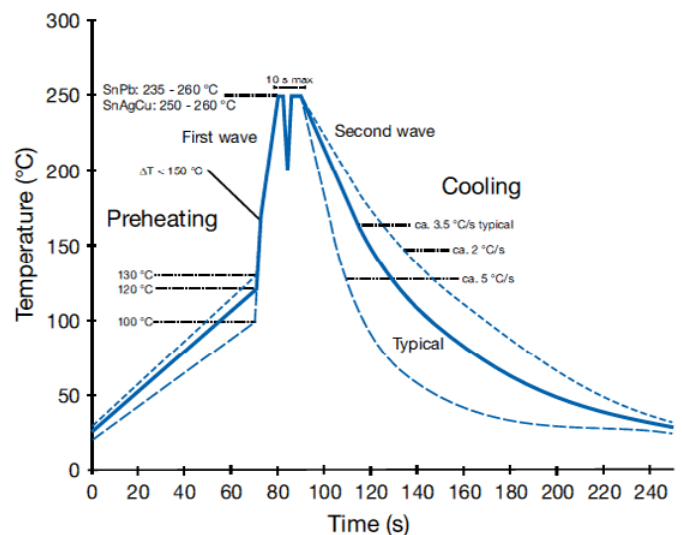

Marking

- KEMET's logo
- Series
- Capacitance
- Capacitance tolerance
- Rated voltage
- Capacitor class
- Approval marks
- Manufacturing date code
- IEC climatic category
- Passive flammability class
- Manufacturing plant

Packaging Quantities

Lead Spacing (mm)	Thickness (mm)	Height (mm)	Length (mm)	Bulk Short Leads	Bulk Long Leads	Standard Reel ø 355 mm	Large Reel ø 500 mm	Ammo	Pizza
22.5	6	15	26.5	1404	702	300	700	464	660
	7	16	26.5	1188	594	250	550	380	564
	8.5	17	26.5	972	486	250	450	280	468
	10	18.5	26.5	810	405	160	350	235	396
	11	20	26.5	630	378	190	350	217	360
	13	22	26.5	540	324	150	300	200	300
27.5	9	17	32	816	408		450		
	10	20	32	600	360		350		
	11	20	32	560	336		350		
	13	22	32	480	288		300		
	13	25	32	480	288				
	14	28	32	352	176				
	15	24.5	32	400	240				
	18	33	32	256	128				
	22	37	32	168	112				
37.5	11	22	41.5	420	252				
	13	24	41.5	360	216				
	16	28.5	41.5	216	108				
	19	32	41.5	192	96				
	20	40	41.5	126	84				
	24	44	41.5	108	72				
	30	45	41.5	90	60				

Lead Taping & Packaging (IEC 60286-2)

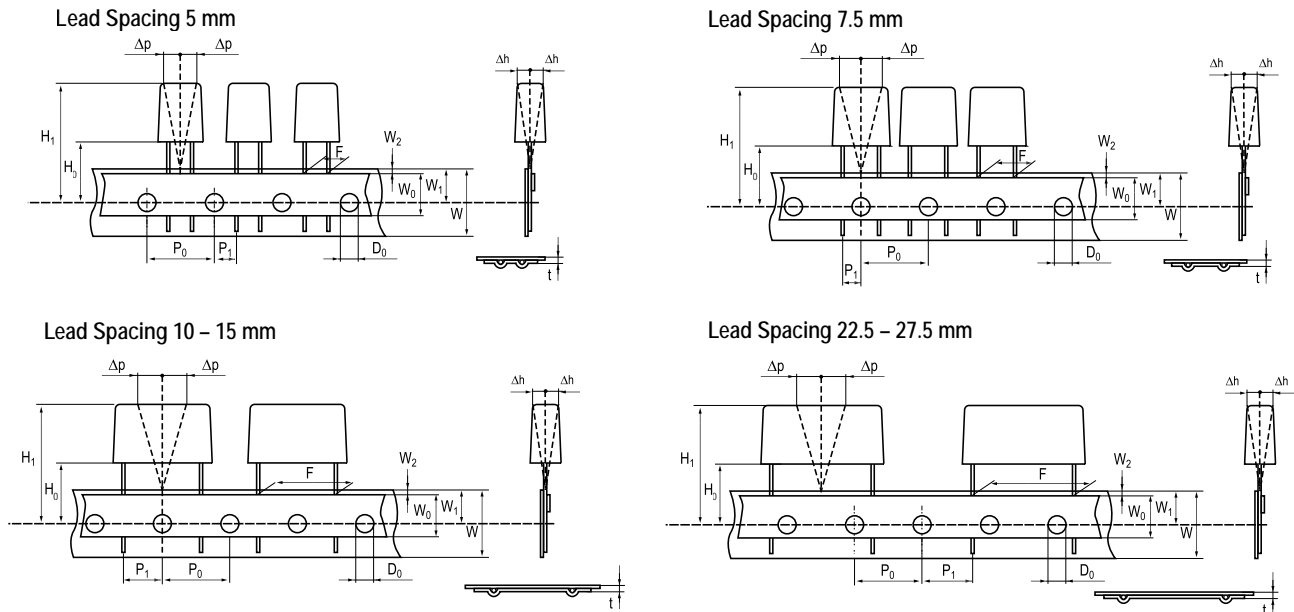

Taping Specification

Dimensions in mm									Standard IEC 60286-2
Lead spacing	+6/-0.1	F	5	7.5	10	15	22.5	27.5	F
Carrier tape width	+1/-0.5	W	18	18	18	18	18	18	18 ^{+1/-0.5}
Hold-down tape width	Minimum	W ₀	6	6	9	10	10	10	
Position of sprocket hole	+/-0.5	W ₁	9	9	9	9	9	9	9 ^{+0.75/-0.5}
Distance between tapes	Maximum	W ₂	3	3	3	3	3	3	3
Sprocket hole diameter	+/-0.2	D ₀	4	4	4	4	4	4	4
Feed hole lead spacing	+/-0.2 ⁽¹⁾	P ₀ ⁽³⁾	12.7	12.7	12.7	12.7	12.7	12.7	12.7
Distance lead – feed hole	+/-0.7	P ₁	3.85	3.75	7.7	5.2	7.8	5.3	P ¹
Deviation tape – plane	Maximum	Δp	1.3	1.3	1.3	1.3	1.3	1.3	1.3
Lateral deviation	+/-2	Δh	2	2	2	2	2	2	2
Total thickness	+/-0.2	t	0.7	0.7	0.7	0.7	0.9 ^{MAX}	0.9 ^{MAX}	0.9 ^{MAX}
Sprocket hole/cap body	+/-0.5	H ₀ ⁽²⁾	18.5 ^{+/-0.5}	18.5 ^{+/-0.5}	18.5 ^{+/-0.5}	18.5 ^{+/-0.5}	18.5 ^{+/-0.5}	18.5 ^{+/-0.5}	18 ^{+2/-0}

(1) Maximum cumulative feed hole error, 1 mm per 20 parts.

(2) 16.5 mm available on request.

(3) 15 mm available on request (F ≥ 10 mm).

Lead Taping & Packaging (IEC 60286–2) cont'd

Ammo Specifications

Series	Dimensions (mm)		
	H	W	T
R4x, R4x+R, R7x, RSB	360	340	59
F5A, F5B, F5D			
F6xx, F8xx			
PHExxx, PMExxx, PMRxxx	330	330	50

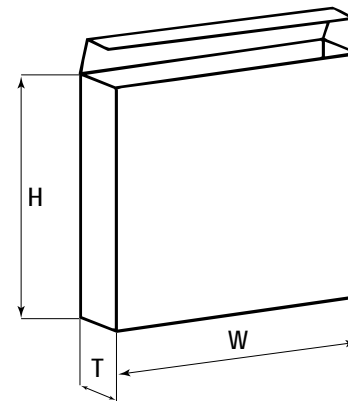

Reel Specifications

Series	Dimensions (mm)		
	D	H	W
R4x, R4x+R, R7x, RSB	355 500	30	55 (Max)
F5A, F5B, F5D		25	
F6xx, F8xx			
PHExxx, PMExxx, PMRxxx	360 500	30	46 (Max)

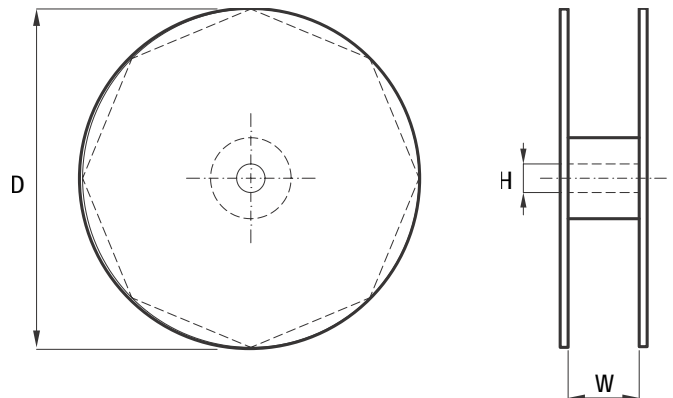

Manufacturing Date Code (IEC–60062)

Y = Year, Z = Month			
Year	Code	Month	Code
2000	M	January	1
2001	N	February	2
2002	P	March	3
2003	R	April	4
2004	S	May	5
2005	T	June	6
2006	U	July	7
2007	V	August	8
2008	W	September	9
2009	X	October	O
2010	A	November	N
2011	B	December	D
2012	C		
2013	D		
2014	E		
2015	F		
2016	H		
2017	J		
2018	K		
2019	L		
2020	M		

KEMET Corporation World Headquarters

2835 KEMET Way
Simpsonville, SC 29681

Mailing Address:
P.O. Box 5928
Greenville, SC 29606

www.kemet.com
Tel: 864-963-6300
Fax: 864-963-6521

Corporate Offices
Fort Lauderdale, FL
Tel: 954-766-2800

North America

Southeast
Lake Mary, FL
Tel: 407-855-8886

Northeast
Wilmington, MA
Tel: 978-658-1663

Central
Novi, MI
Tel: 248-994-1030

West
Milpitas, CA
Tel: 408-433-9950

Mexico
Guadalajara, Jalisco
Tel: 52-33-3123-2141

Europe

Southern Europe
Paris, France
Tel: 33-1-4646-1006

Sasso Marconi, Italy
Tel: 39-051-939111

Central Europe
Landsberg, Germany
Tel: 49-8191-3350800

Kamen, Germany
Tel: 49-2307-438110

Northern Europe
Bishop's Stortford, United Kingdom
Tel: 44-1279-460122

Espoo, Finland
Tel: 358-9-5406-5000

Asia

Northeast Asia
Hong Kong
Tel: 852-2305-1168

Shenzhen, China
Tel: 86-755-2518-1306

Beijing, China
Tel: 86-10-5829-1711

Shanghai, China
Tel: 86-21-6447-0707

Taipei, Taiwan
Tel: 886-2-27528585

Southeast Asia
Singapore
Tel: 65-6586-1900

Penang, Malaysia
Tel: 60-4-6430200

Bangalore, India
Tel: 91-806-53-76817

Note: KEMET reserves the right to modify minor details of internal and external construction at any time in the interest of product improvement. KEMET does not assume any responsibility for infringement that might result from the use of KEMET Capacitors in potential circuit designs. KEMET is a registered trademark of KEMET Electronics Corporation.

Other KEMET Resources

Tools	
Resource	Location
Configure A Part: CapEdge	http://capacitoredge.kemet.com
SPICE & FIT Software	http://www.kemet.com/spice
Search Our FAQs: KnowledgeEdge	http://www.kemet.com/keask
Electrolytic LifeCalculator	http://www.kemet.com:8080/elc

Product Information	
Resource	Location
Products	http://www.kemet.com/products
Technical Resources (Including Soldering Techniques)	http://www.kemet.com/technicalpapers
RoHS Statement	http://www.kemet.com/rohs
Quality Documents	http://www.kemet.com/qualitydocuments

Product Request	
Resource	Location
Sample Request	http://www.kemet.com/sample
Engineering Kit Request	http://www.kemet.com/kits

Contact	
Resource	Location
Website	www.kemet.com
Contact Us	http://www.kemet.com/contact
Investor Relations	http://www.kemet.com/ir
Call Us	1-877-MyKEMET
Twitter	http://twitter.com/kemetcapacitors

Disclaimer

All product specifications, statements, information and data (collectively, the "Information") in this datasheet are subject to change. The customer is responsible for checking and verifying the extent to which the Information contained in this publication is applicable to an order at the time the order is placed.

All Information given herein is believed to be accurate and reliable, but it is presented without guarantee, warranty, or responsibility of any kind, expressed or implied.

Statements of suitability for certain applications are based on KEMET Electronics Corporation's ("KEMET") knowledge of typical operating conditions for such applications, but are not intended to constitute – and KEMET specifically disclaims – any warranty concerning suitability for a specific customer application or use. The Information is intended for use only by customers who have the requisite experience and capability to determine the correct products for their application. Any technical advice inferred from this Information or otherwise provided by KEMET with reference to the use of KEMET's products is given gratis, and KEMET assumes no obligation or liability for the advice given or results obtained.

Although KEMET designs and manufactures its products to the most stringent quality and safety standards, given the current state of the art, isolated component failures may still occur. Accordingly, customer applications which require a high degree of reliability or safety should employ suitable designs or other safeguards (such as installation of protective circuitry or redundancies) in order to ensure that the failure of an electrical component does not result in a risk of personal injury or property damage.

Although all product-related warnings, cautions and notes must be observed, the customer should not assume that all safety measures are indicated or that other measures may not be required.

