

# PNP Series Sealed Pushbutton Switch



A  
Pushbutton

## Features/Benefits

- IP68 sealed to endure harsh environments
- 1,000,000 life cycle
- Longer solder leads for ease of wire installation
- Multiple housing styles
- Up to 5A resistive load
- Wirelead options available
- RoHS compliant

## Typical Applications

- Control Grips
- Off-Road Panels
- Heavy Equipment
- Industrial Instruments
- Lifts
- Conveyor Controls



## Specifications

FUNCTION: SPST, SPDT Double Break (Form Z) Momentary  
CONTACT ARRANGEMENT: N.O. and N.C.  
MOUNTING TYPE: Threaded front mount  
TORQUE SPEC FOR THREADED BODY: Do not exceed 10 in-lbs (1.35 N-m)

DIELECTRIC STRENGTH: 1000 V AC for 1 min.  
INSULATION RESISTANCE: 1 G  $\Omega$  @ 500 VDC  
INITIAL CONTACT RESISTANCE 50 m $\Omega$  max (without wire leads)  
BOUNCE TIME: <5 ms

## Mechanical

OPERATING LIFE: 1,000,000 cycles  
TOTAL TRAVEL: 2 mm max.  
OPERATING POINT 0.9  $\pm$  0.25 mm  
OVER TRAVEL: 0.25 mm min.  
OPERATING FORCE: 8N  $\pm$  1.5N  
VIBRATION: 10-500 Hz 10g Max  
SHOCK: 50g 11ms sawtooth wave

## Materials

HOUSING: PBT/PC  
BASE: PBT  
CAP: PBT  
ACTUATOR: PBT  
INTERNAL SEAL: Silicone rubber  
TERMINALS: Copper with silver nickel inlay, silver plating  
MOVABLE CONTACT: Copper alloy, gold over silver plating  
TERMINAL SEAL: Epoxy

## Electrical

CONTACT RATING:  
Option "Q" Silver  
5A/32 VDC resistive (25,000 cycles)  
3A/32 VDC resistive (25,000 cycles)  
Option "G" Gold over Silver  
10mA/5 VDC resistive (1,000,000 cycles)

## Operating Environment

OPERATING TEMPERATURE: -40°C to +85°C  
ESD PROTECTION: 15KV min.

## Process Environment

SEALING: IP68

**NOTE:** Specifications and materials listed above are for switches with standard options. For information on specific and custom switches, please contact Customer Service.

## Build-A-Switch

To order, simply select desired option from each category and place in the appropriate box.



**Designation**  
PNP PNP Series

**Operating Force**  
8 8 Newtons

**Actuator Style**  
S Standard  
E Extended (D housing style only)

**Actuator Color \***  
2 Black (STD)  
3 Red  
5 Yellow

**Housing Style**  
T Standard threaded mount  
D Dome bezel

**Housing Color**  
2 Black (STD)

**Terminal Seal**  
E Epoxy  
All models are epoxy sealed

**Contact Material**  
Q Silver (STD)  
G Gold over silver

**Termination**  
O2 PC Pin (G contact material only)  
O3 Solder Lug (STD)  
W2 2 x 12" 22 AWG UL1569 wire (overmolded)  
W3 3 x 12" 22 AWG UL1569 wire (overmolded)  
W4 4 x 12" 22 AWG UL1569 wire (overmolded)

**Circuit**  
C SPDT - Double Break  
W SPST NC - Double Break  
Y SPST NO - Double Break

\* Additional colors available, please contact Customer Service

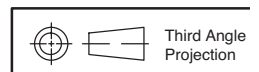

Dimensions are shown: mm (inches)  
Specifications and dimensions subject to change





# PNP Series Sealed Pushbutton Switch

Pushbutton

A

## STANDARD VIEW

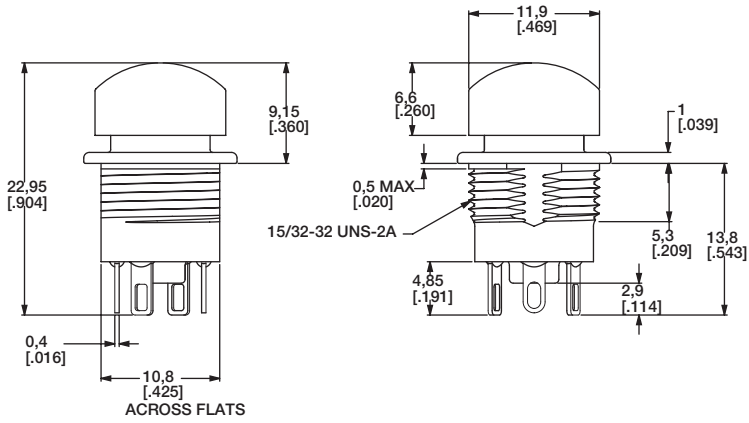

### ELECTRICAL SCHEMATIC

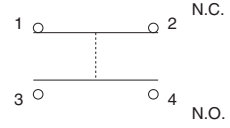

## OPERATING FORCE

OPTION CODE	OPERATING FORCE
<b>8</b>	8 N

## ACTUATOR STYLE

**S** STANDARD

**E** EXTENDED (D HOUSING STYLE ONLY)

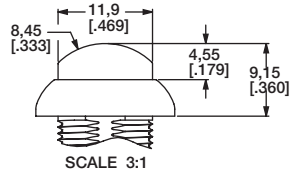
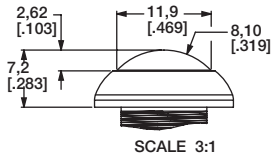

## ACTUATOR COLOR

OPTION CODE	ACTUATOR COLOR
<b>2</b>	Black
<b>3</b>	Red
<b>5</b>	Yellow



## HOUSING STYLE

### T STANDARD THREADED MOUNT

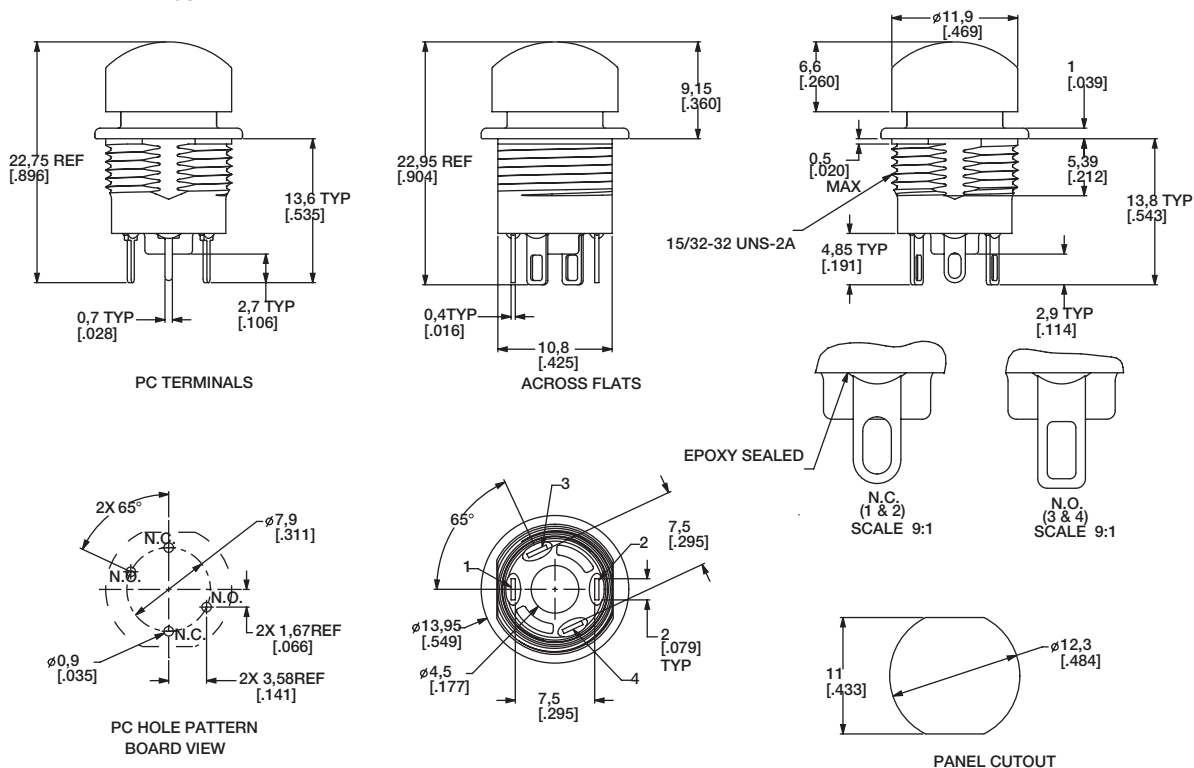

### D DOME BEZEL

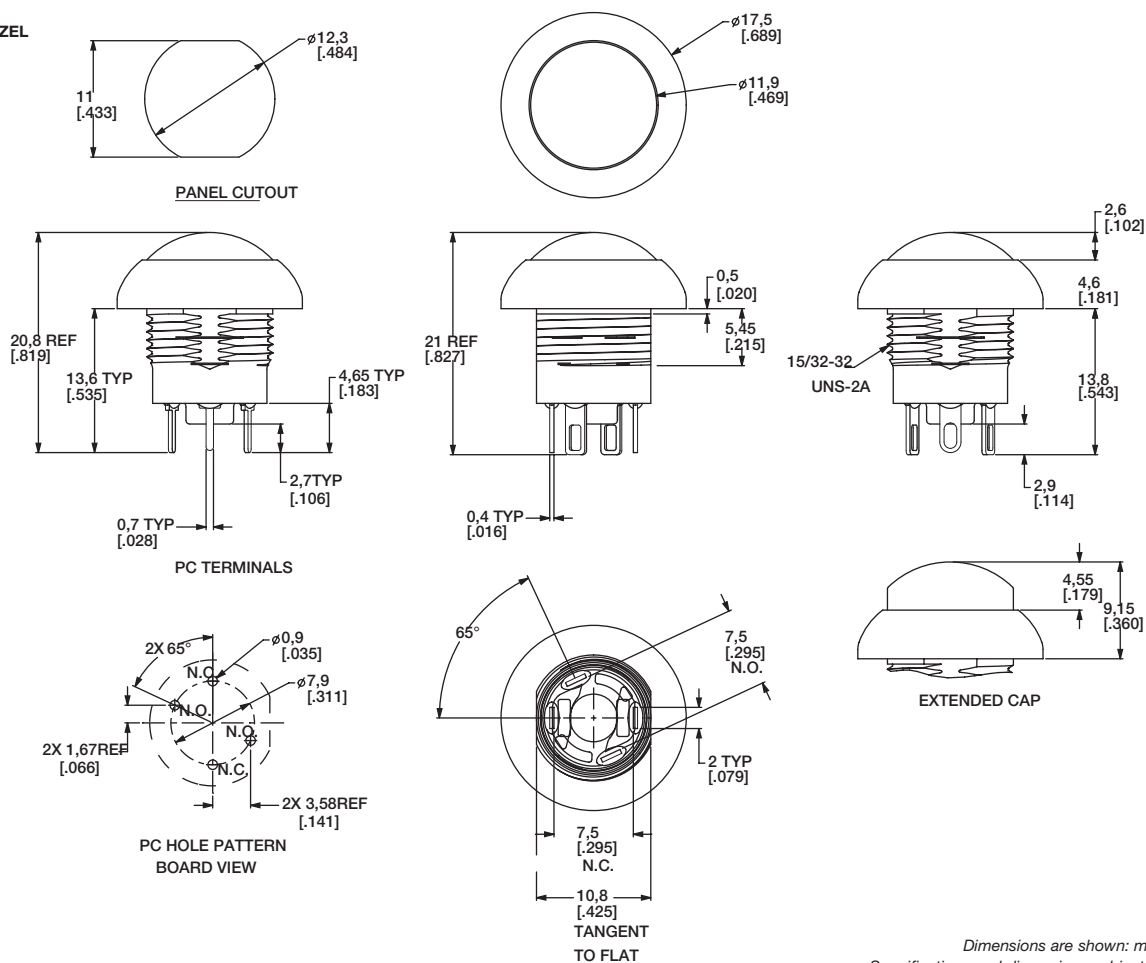



# PNP Series Sealed Pushbutton Switch

Pushbutton  
A

## HOUSING COLOR

OPTION CODE	COLOR
<b>2</b>	Black (STD)

## CIRCUIT

**W** SPST NC - Double Break

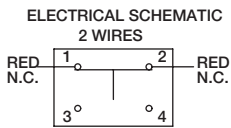

**Y** SPST NO - Double Break

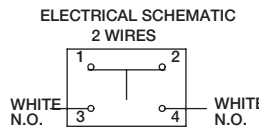

**C** SPDT - Double Break

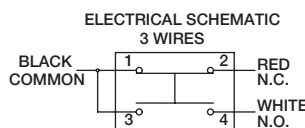

**C** SPDT - Double Break

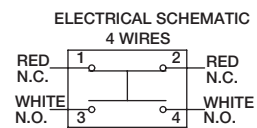

## TERMINATION

**02** PC PIN

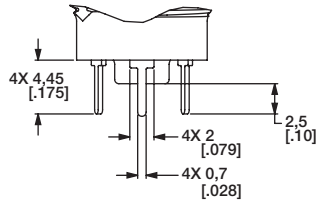

**03** SOLDER LUG (STD)

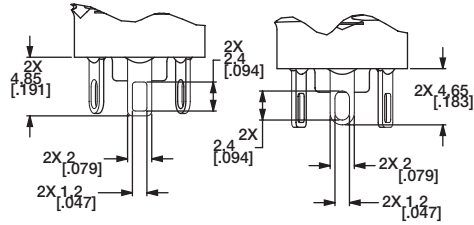

**W2** 2 x 12" 22 AWG UL1569 wire (overmolded)

**W3** 3 x 12" 22 AWG UL1569 wire (overmolded)

**W4** 4 x 12" 22 AWG UL1569 wire (overmolded)

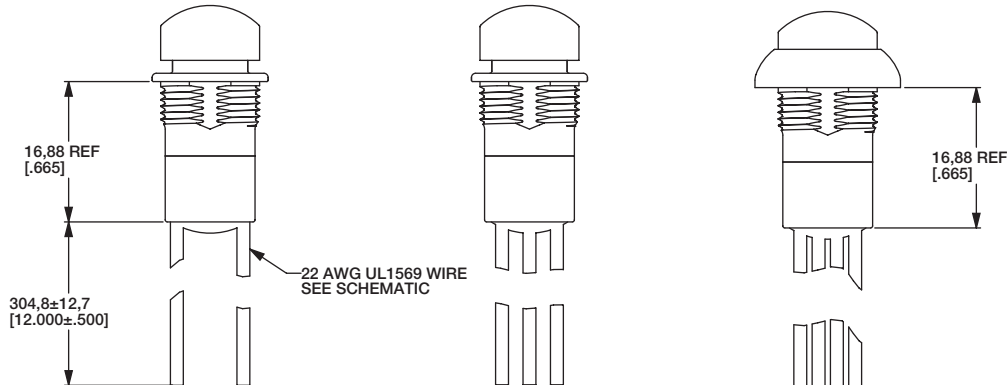

### CONTACT MATERIAL

OPTION CODE	CONTACT MATERIAL
<b>Q</b>	Silver (STD)
<b>G</b>	Gold over silver

### TERMINAL SEAL

#### **E** EPOXY

All models are epoxy sealed

### HARDWARE

#### HEX NUT

707100201 Nickel-plated

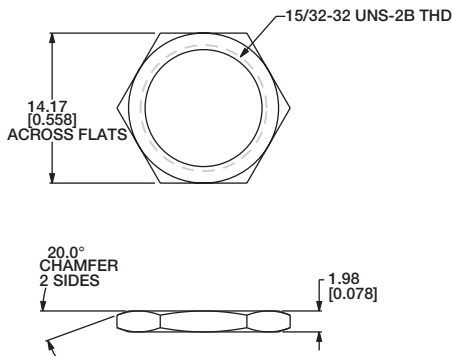

#### LOCKWASHER

700302202

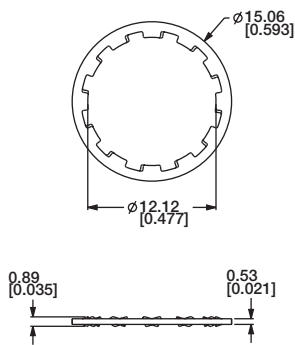

#### PANEL GASKET

851D02000

