

## 2-Phase Stepper-Motor Driver Bipolar IC

TCA 3727

### Features

- $2 \times 0.75$  amp. / 50 V outputs
- Integrated driver, control logic and current control (chopper)
- Fast free-wheeling diodes
- Max. supply voltage 52 V
- Outputs free of crossover current
- Offset-phase turn-ON of output stages
- Z-diode for logic supply
- Low standby-current drain
- Full, half, quarter, mini step

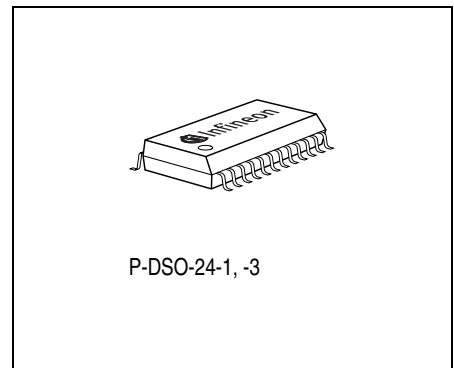
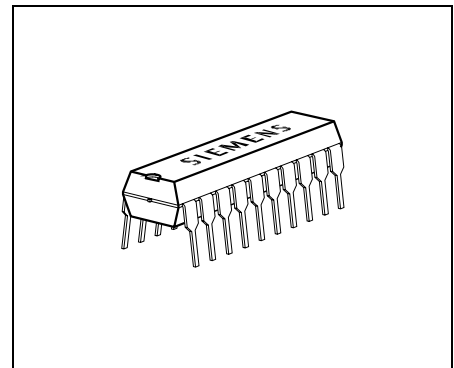

### Description

TCA 3727 is a bipolar, monolithic IC for driving bipolar stepper motors, DC motors and other inductive loads that operate on constant current. The control logic and power output stages for two bipolar windings are integrated on a single chip which permits switched current control of motors with 0.75 A per phase at operating voltages up to 50 V.

The direction and value of current are programmed for each phase via separate control inputs. A common oscillator generates the timing for the current control and turn-on with phase offset of the two output stages. The two output stages in a full-bridge configuration have integrated, fast free-wheeling diodes and are free of crossover current. The logic is supplied either separately with 5 V or taken from the motor supply voltage by way of a series resistor and an integrated Z-diode. The device can be driven directly by a microprocessor with the possibility of all modes from full step through half step to mini step.

Type	Ordering Code	Package
TCA 3727	Q67000-A8302	P-DIP-20-6
TCA 3727 G	Q67000-A8335	P-DSO-24-3

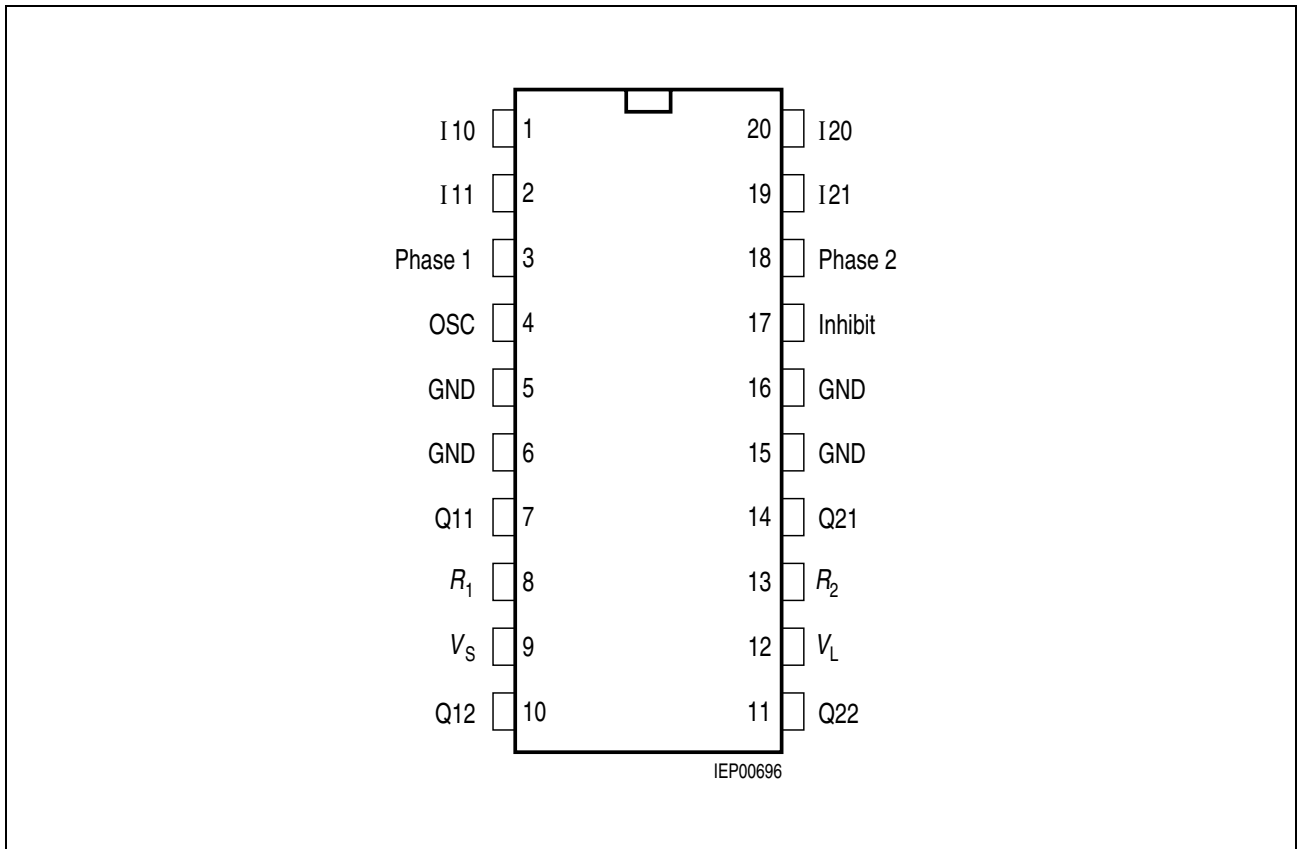

**Figure 1 Pin Configuration TCA 3727 (top view)**

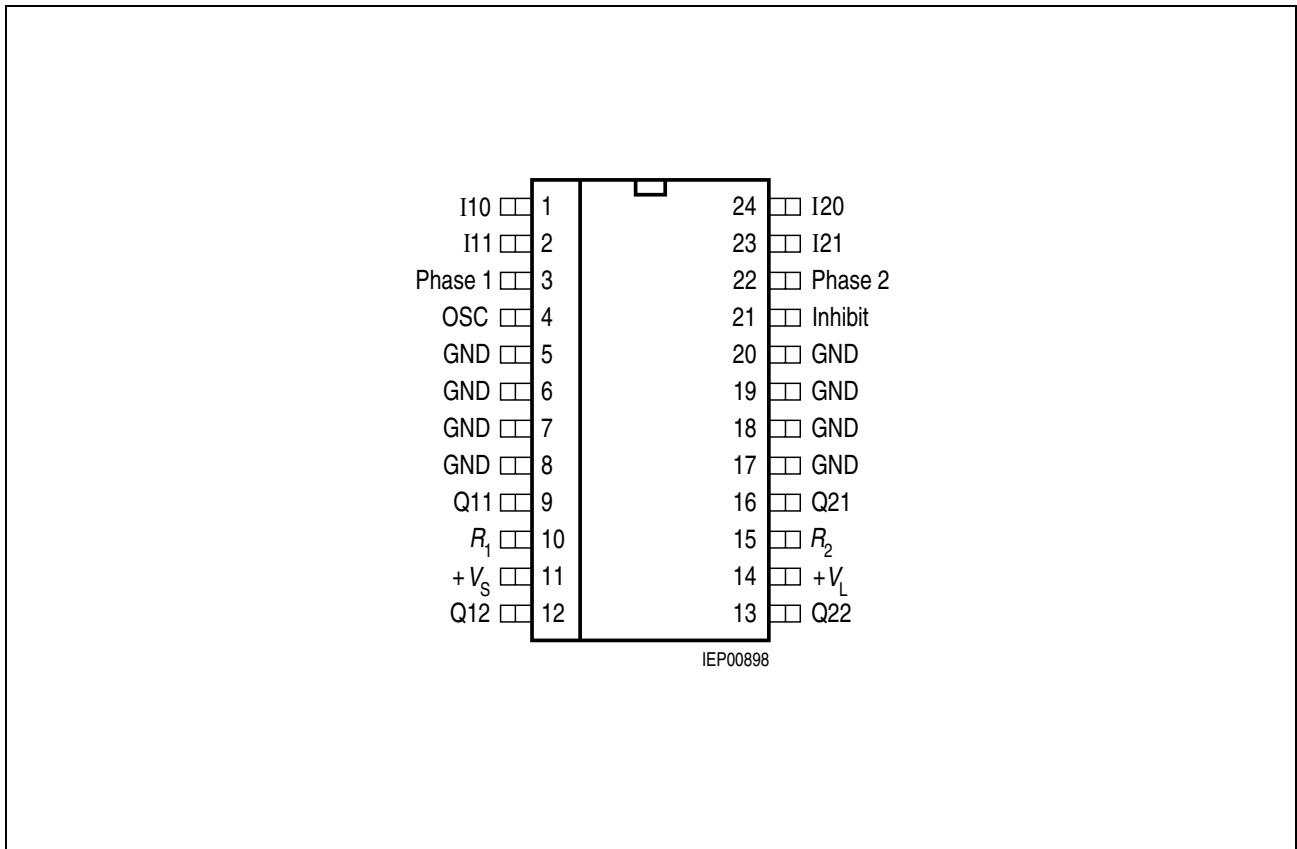

**Figure 2 Pin Configuration TCA 3727 G (top view)**

**Table 1 Pin Definitions and Functions**

Pin No.	Function
1, 2, 19, 20 (1, 2, 23, 24) <sup>1)</sup>	<b>Digital control inputs IX0, IX1</b> for the magnitude of the <b>current</b> of the particular phase. See <a href="#">Table 2</a> .
3	<b>Input Phase 1</b> ; controls the current through phase winding 1. On H-potential the phase current flows from Q11 to Q12, on L-potential in the reverse direction.
5, 6, 15, 16 (5, 6, 7, 8, 17, 18, 19, 20) <sup>1)</sup>	<b>Ground</b> ; all pins are connected internally.
4	<b>Oscillator</b> ; works at approx. 25 kHz if this pin is wired to ground across 2.2 nF.
8 (10) <sup>1)</sup>	<b>Resistor R<sub>1</sub></b> for sensing the current in phase 1.
7, 10 (9, 12) <sup>1)</sup>	<b>Push-pull outputs Q11, Q12</b> for phase 1 with integrated free-wheeling diodes.

**Table 1 Pin Definitions and Functions (cont'd)**

Pin No.	Function
9 (11) <sup>1)</sup>	<b>Supply voltage</b> ; block to ground, as close as possible to the IC, with a stable electrolytic capacitor of at least 10 $\mu$ F in parallel with a ceramic capacitor of 220 nF.
12 (14) <sup>1)</sup>	<b>Logic supply voltage</b> ; either supply with 5 V or connect to $+V_S$ across a series resistor. A Z-diode of approx. 7 V is integrated. In both cases block to ground directly on the IC with a stable electrolytic capacitor of 10 $\mu$ F in parallel with a ceramic capacitor of 100 nF.
11, 14 (13, 16) <sup>1)</sup>	<b>Push-pull outputs Q22, Q21</b> for phase 2 with integrated free wheeling diodes.
13 (15) <sup>1)</sup>	<b>Resistor <math>R_2</math></b> for sensing the current in phase 2.
17 (21) <sup>1)</sup>	<b>Inhibit input</b> ; the IC can be put on standby by low potential on this pin. This reduces the current consumption substantially.
18 (22) <sup>1)</sup>	<b>Input phase 2</b> ; controls the current flow through phase winding 2. On H-potential the phase current flows from Q21 to Q22, on L potential in the reverse direction.

1) TCA 3727 G only

**Table 2 Digital Control Inputs IX0, IX1**

typical  $I_{max}$  with  $R_{sense} = 1 \Omega$ , 750 mA

IX1	IX0	Phase Current	Example of Motor Status
H	H	0	No current
H	L	$1/3 I_{max}$	Hold
L	H	$2/3 I_{max}$	Set
L	L	$I_{max}$	Accelerate

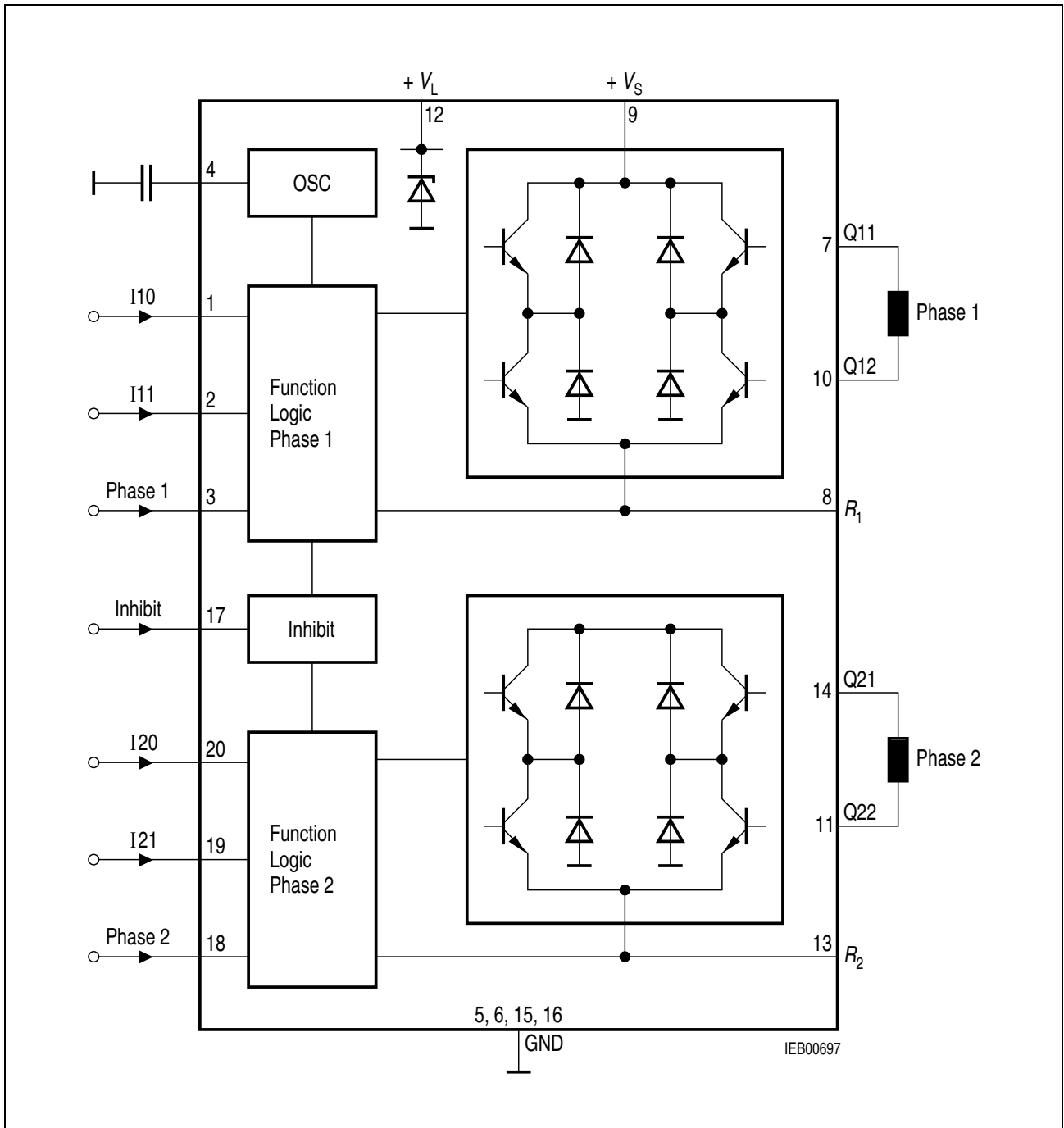

Figure 3 Block Diagram TCA 3727

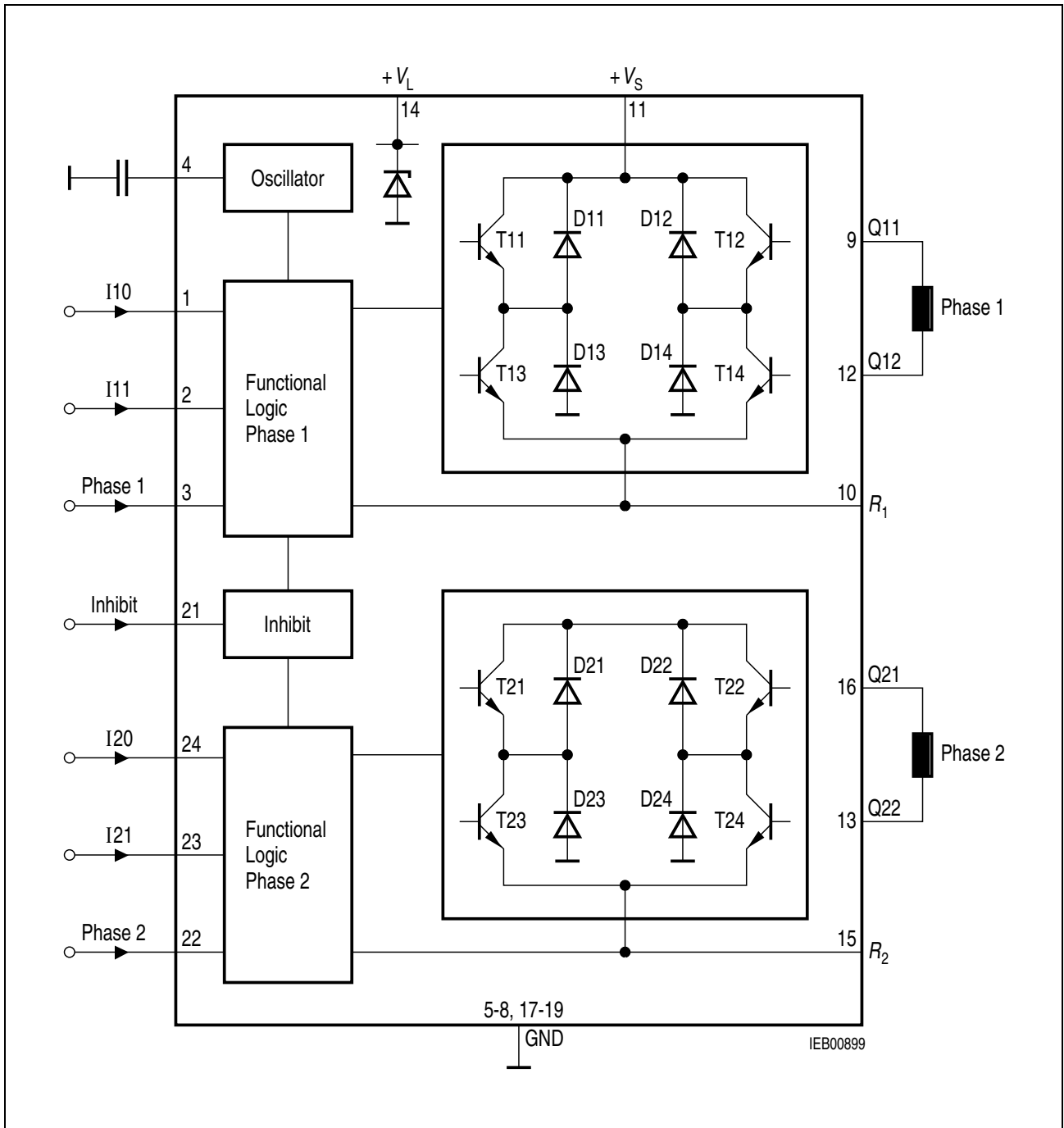

Figure 4 Block Diagram TCA 3727 G

**Table 3 Absolute Maximum Ratings**

$T_A = -40$  to  $125$  °C

Parameter	Symbol	Limit Values		Unit	Remarks
		Min.	Max.		
Supply voltage	$V_S$	0	52	V	–
Logic supply voltage	$V_L$	0	6.5	V	Z-diode
Z-current of $V_L$	$I_L$	–	50	mA	–
Output current	$I_Q$	-1	1	A	–
Ground current	$I_{GND}$	-2	2	A	–
Logic inputs	$V_{IXX}$	-6	$V_L + 0.3$	V	IXX; Phase 1, 2; Inhibit
$R_1, R_2$ , oscillator input voltage	$V_{RX},$ $V_{OSC}$	-0.3	$V_L + 0.3$	V	–
Junction temperature	$T_j$	–	125	°C	–
		–	150	°C	max. 10,000 h
Storage temperature	$T_{stg}$	-50	125	°C	–

**Attention: Stresses above those listed here may cause permanent damage to the device. Exposure to absolute maximum rating conditions for extended periods may affect device reliability.**

**Table 4 Operating Range**

Parameter	Symbol	Limit Values		Unit	Remarks
		Min.	Max.		
Supply voltage	$V_S$	5	50	V	–
Logic supply voltage	$V_L$	4.5	6.5	V	without series resistor
Case temperature	$T_C$	-40	110	°C	measured on pin 5 $P_{diss} = 2\text{ W}$
Output current	$I_Q$	-1000	1000	mA	–
Logic inputs	$V_{IXX}$	-5	$V_L$	V	IXX; Phase 1, 2; Inhibit

**Thermal Resistances**

Junction ambient	$R_{th\ ja}$	–	56	K/W	P-DIP-20-6
Junction ambient (soldered on a 35 $\mu\text{m}$ thick 20 $\text{cm}^2$ PC board copper area)	$R_{th\ ja}$	–	40	K/W	P-DIP-20-6
Junction case	$R_{th\ jc}$	–	18	K/W	measured on pin 5 P-DIP-20-6
Junction ambient	$R_{th\ ja}$	–	75	K/W	P-DSO-24-3
Junction ambient (soldered on a 35 $\mu\text{m}$ thick 20 $\text{cm}^2$ PC board copper area)	$R_{th\ ja}$	–	50	K/W	P-DSO-24-3
Junction case	$R_{th\ jc}$	–	15	K/W	measured on pin 5 P-DSO-24-3

*Note: In the operating range, the functions given in the circuit description are fulfilled.*



**Table 5 Characteristics**
 $V_S = 40\text{ V}; V_L = 5\text{ V}; -25\text{ °C} \leq T_j \leq 125\text{ °C}$ 

Parameter	Symbol	Limit Values			Unit	Test Condition
		Min.	Typ.	Max.		

**Current Consumption**

from $+V_S$	$I_S$	–	0.2	0.5	mA	$V_{inh} = L$
from $+V_S$	$I_S$	–	16	20	mA	$V_{inh} = H$ $I_{Q1/2} = 0, I_{XX} = L$
from $+V_L$	$I_L$	–	1.7	3	mA	$V_{inh} = L$
from $+V_L$	$I_L$	–	18	25	mA	$V_{inh} = H$ $I_{Q1/2} = 0, I_{XX} = L$

**Oscillator**

Output charging current	$I_{OSC}$	–	110	–	$\mu\text{A}$	–
Charging threshold	$V_{OSCL}$	–	1.3	–	V	–
Discharging threshold	$V_{OSCH}$	–	2.3	–	V	–
Frequency	$f_{OSC}$	18	25	35	kHz	$C_{OSC} = 2.2\text{ nF}$

**Phase Current Selection ( $R_1; R_2$ )**
**Current Limit Threshold**

No current	$V_{sense\ n}$	–	0	–	mV	$IX0 = H; IX1 = H$
Hold	$V_{sense\ h}$	200	250	300	mV	$IX0 = L; IX1 = H$
Setpoint	$V_{sense\ s}$	460	540	620	mV	$IX0 = H; IX1 = L$
Accelerate	$V_{sense\ a}$	740	825	910	mV	$IX0 = L; IX1 = L$

**Logic Inputs ( $IX1; IX0; \text{Phase } x$ )**

Threshold	$V_I$	1.4 (H→L)	–	2.3 (L→H)	V	–
L-input current	$I_{IL}$	-10	–	–	$\mu\text{A}$	$V_I = 1.4\text{ V}$
L-input current	$I_{IL}$	-100	–	–	$\mu\text{A}$	$V_I = 0\text{ V}$
H-input current	$I_{IH}$	–	–	10	$\mu\text{A}$	$V_I = 5\text{ V}$

**Standby Cutout (inhibit)**

Threshold	$V_{inh}$ (L→H)	2	3	4	V	–
Threshold	$V_{inh}$ (H→L)	1.7	2.3	2.9	V	–
Hysteresis	$V_{inhhy}$	0.3	0.7	1.1	V	–

**Table 5 Characteristics (cont'd)**
 $V_S = 40\text{ V}; V_L = 5\text{ V}; -25\text{ °C} \leq T_j \leq 125\text{ °C}$ 

Parameter	Symbol	Limit Values			Unit	Test Condition
		Min.	Typ.	Max.		
<b>Internal Z-Diode</b>						
Z-voltage	$V_{LZ}$	6.5	7.4	8.2	V	$I_L = 50\text{ mA}$
<b>Power Outputs</b>						
<b>Diode Transistor Sink Pair (D13, T13; D14, T14; D23, T23; D24, T24)</b>						
Saturation voltage	$V_{satl}$	–	0.3	0.6	V	$I_Q = -0.5\text{ A}$
Saturation voltage	$V_{satl}$	–	0.5	1	V	$I_Q = -0.75\text{ A}$
Reverse current	$I_{RI}$	–	–	300	$\mu\text{A}$	$V_Q = 40\text{ V}$
Forward voltage	$V_{FI}$	–	0.9	1.3	V	$I_Q = 0.5\text{ A}$
Forward voltage	$V_{FI}$	–	1	1.4	V	$I_Q = 0.75\text{ A}$
<b>Diode Transistor Source Pair (D11, T11; D12, T12; D21, T21; D22, T22)</b>						
Saturation voltage	$V_{satuC}$	–	0.9	1.2	V	$I_Q = 0.5\text{ A};$ charge
Saturation voltage	$V_{satuD}$	–	0.3	0.7	V	$I_Q = 0.5\text{ A};$ discharge
Saturation voltage	$V_{satuC}$	–	1.1	1.4	V	$I_Q = 0.75\text{ A};$ charge
Saturation voltage	$V_{satuD}$	–	0.5	1	V	$I_Q = 0.75\text{ A};$ discharge
Reverse current	$I_{Ru}$	–	–	300	$\mu\text{A}$	$V_Q = 0\text{ V}$
Forward voltage	$V_{Fu}$	–	1	1.3	V	$I_Q = -0.5\text{ A}$
Forward voltage	$V_{Fu}$	–	1.1	1.4	V	$I_Q = -0.75\text{ A}$
Diode leakage current	$I_{SL}$	–	1	2	mA	$I_F = -0.75\text{ A}$

*Note: The listed characteristics are ensured over the operating range of the integrated circuit. Typical characteristics specify mean values expected over the production spread. If not otherwise specified, typical characteristics apply at  $T_A = 25\text{ °C}$  and the given supply voltage.*

**Quiescent Current  $I_S, I_L$  versus Supply Voltage  $V_S$**

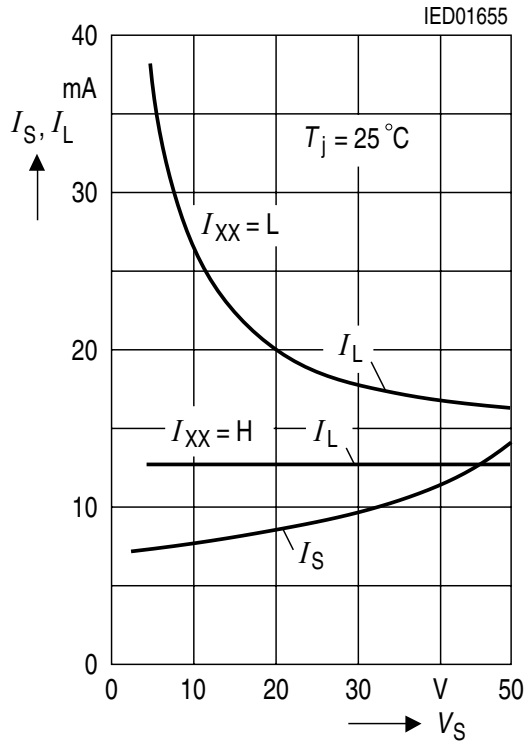

**Quiescent Current  $I_S, I_L$  versus Junction Temperature  $T_j$**

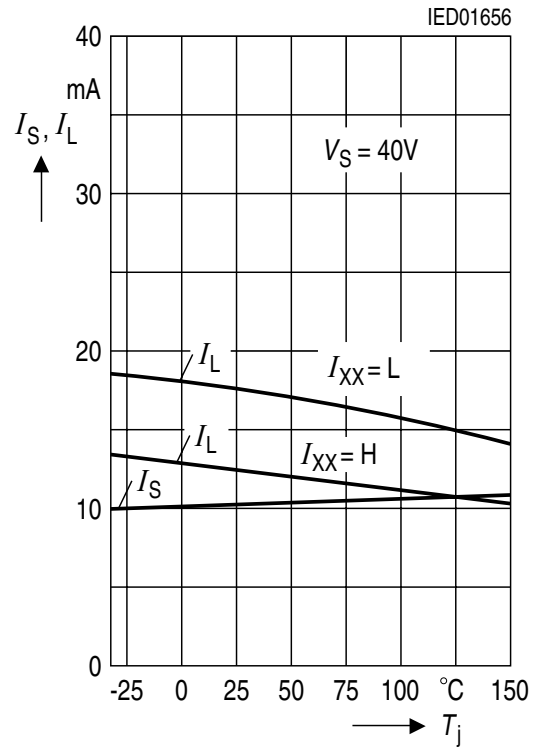

**Output Current  $I_{QX}$  versus Junction Temperature  $T_j$**

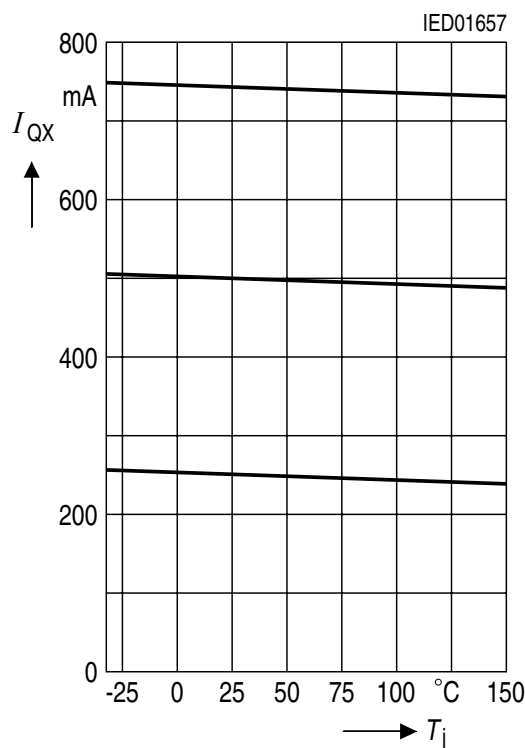

**Operating Condition:**

- $V_L = 5\text{ V}$
- $V_{Inh} = H$
- $C_{OSC} = 2.2\text{ nF}$
- $R_{sense} = 1\text{ }\Omega$
- Load:  $L = 10\text{ mH}$ ,  $R = 2.4\text{ }\Omega$
- $f_{phase} = 50\text{ Hz}$
- mode: fullstep

**Output Saturation Voltages  $V_{sat}$  versus Output Current  $I_Q$**

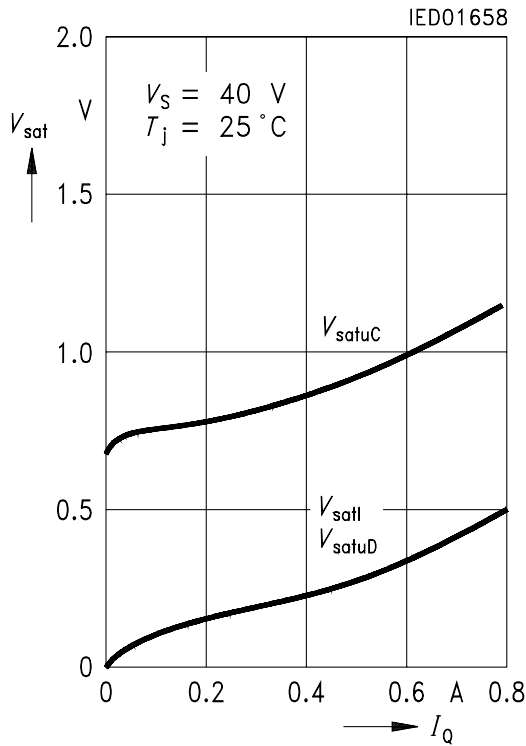

**Forward Current  $I_F$  of Free-Wheeling Diodes versus Forward Voltages  $V_F$**

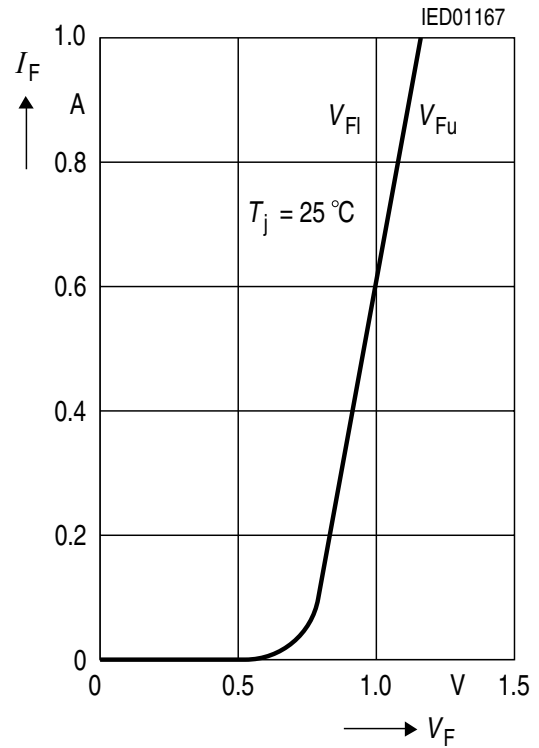

**Typical Power Dissipation  $P_{tot}$  versus Output Current  $I_Q$  (non stepping)**

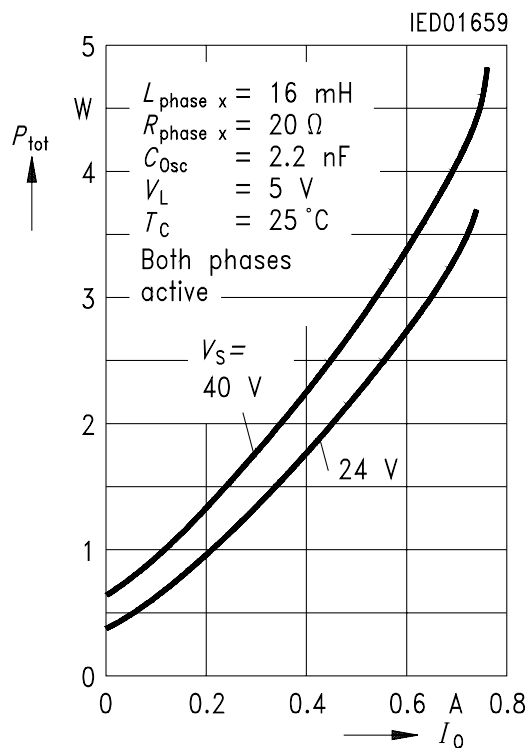

**Permissible Power Dissipation  $P_{tot}$  versus Case Temperature  $T_C$**

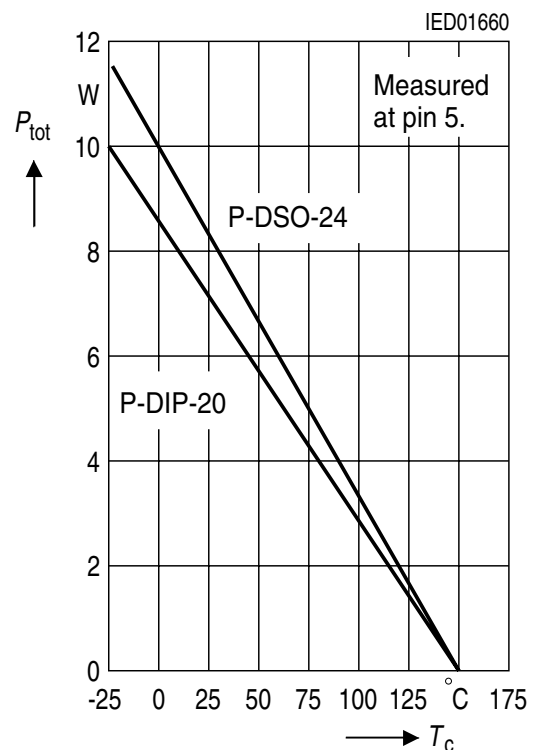

**Input Characteristics of IXX, Phase X, Inhibit**

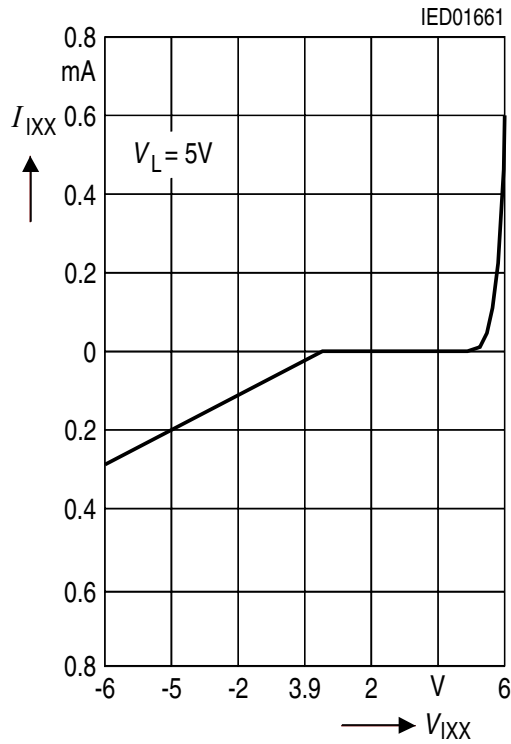

**Input Current of Inhibit versus Junction Temperature  $T_j$**

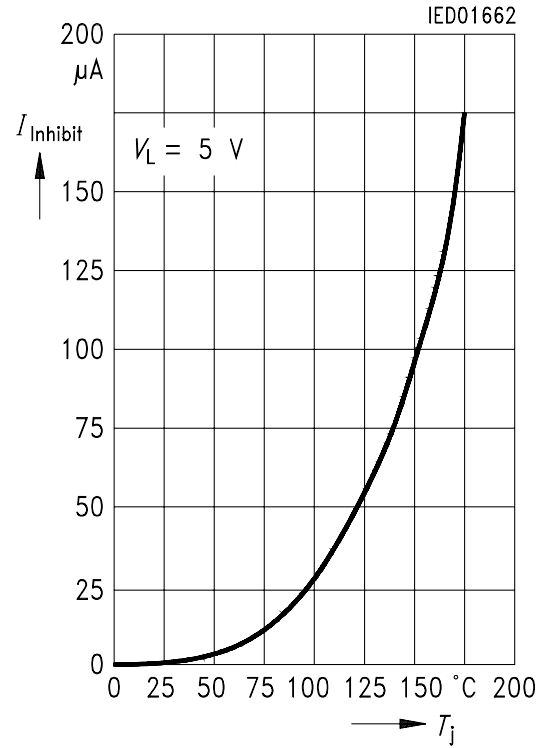

**Oscillator Frequency  $f_{OSC}$  versus Junction Temperature  $T_j$**

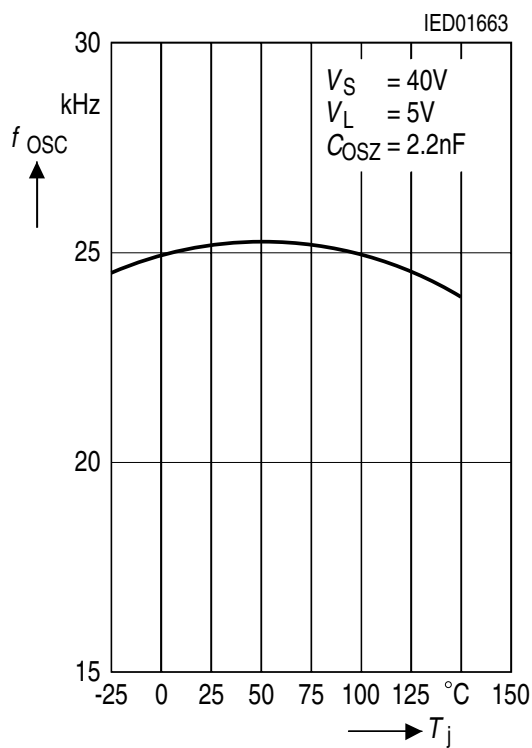



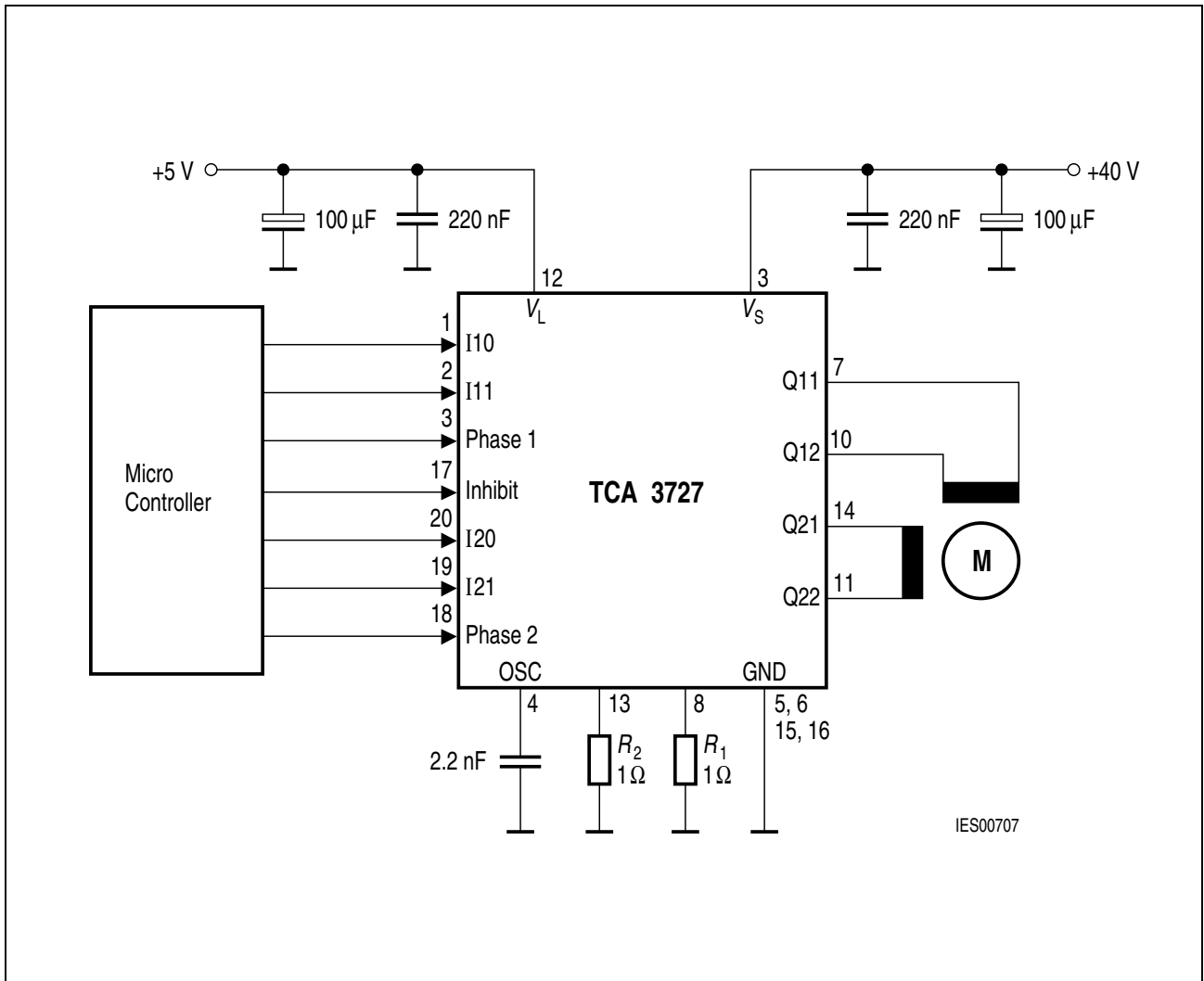
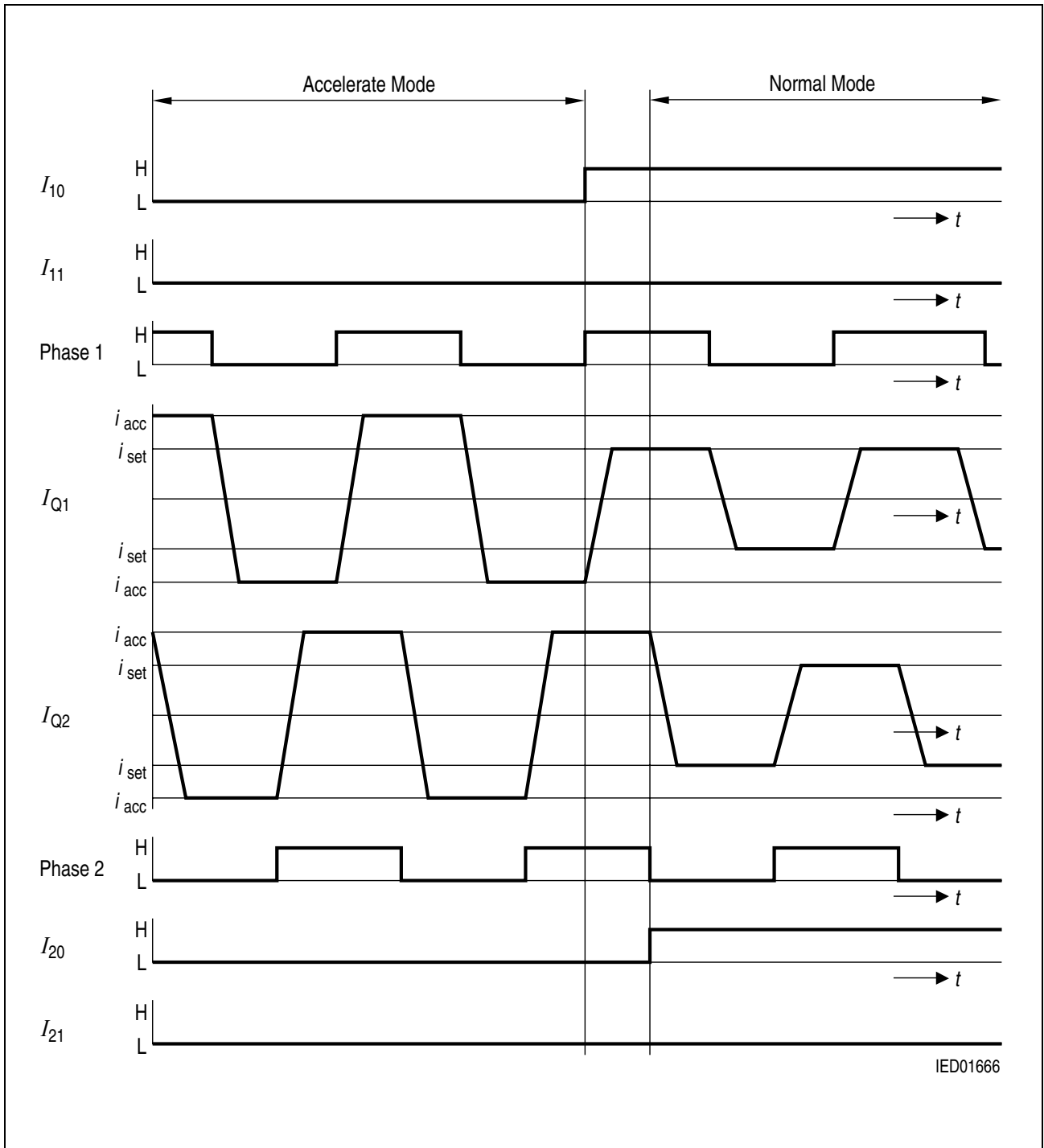
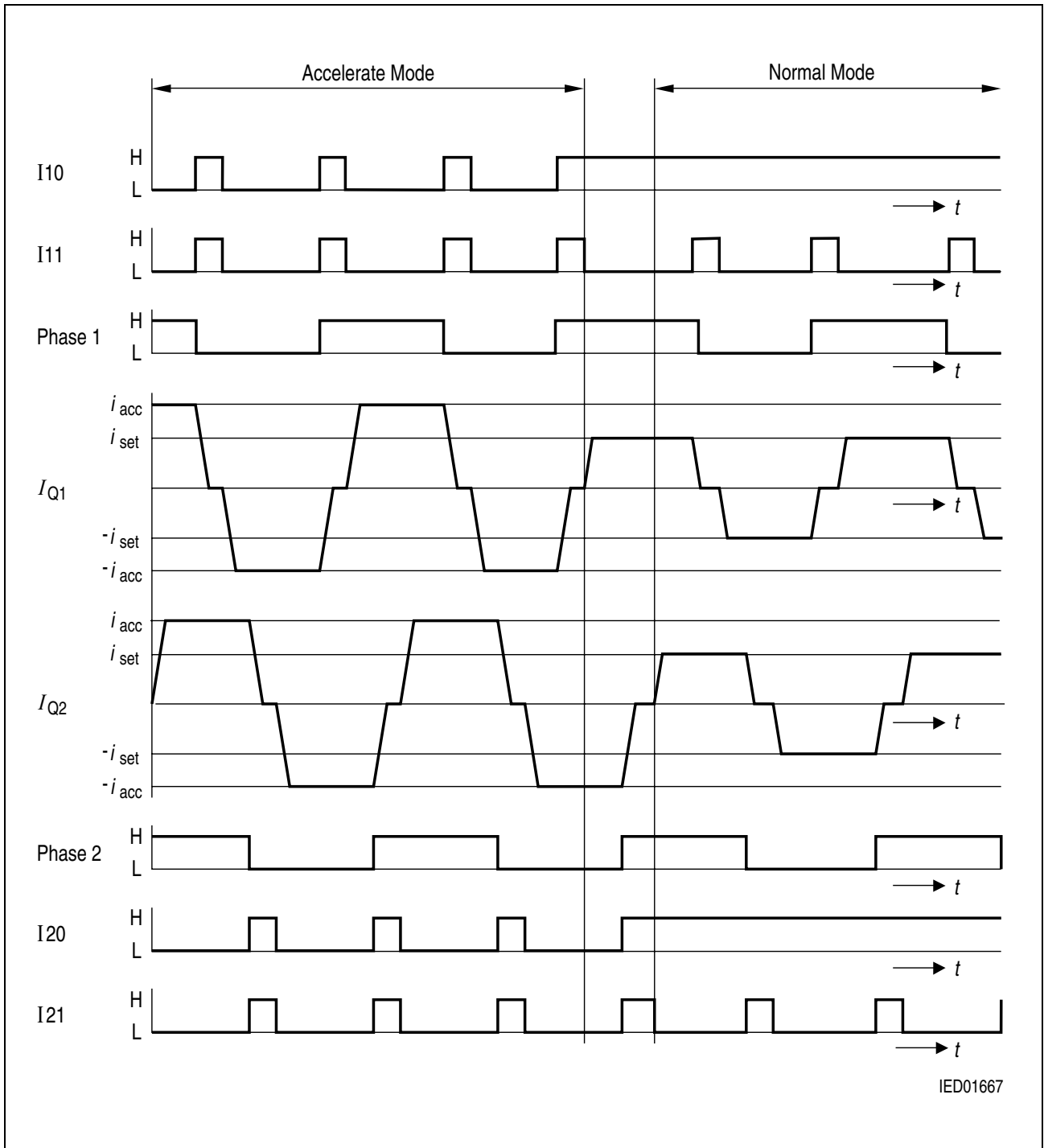

Figure 6 Application Circuit

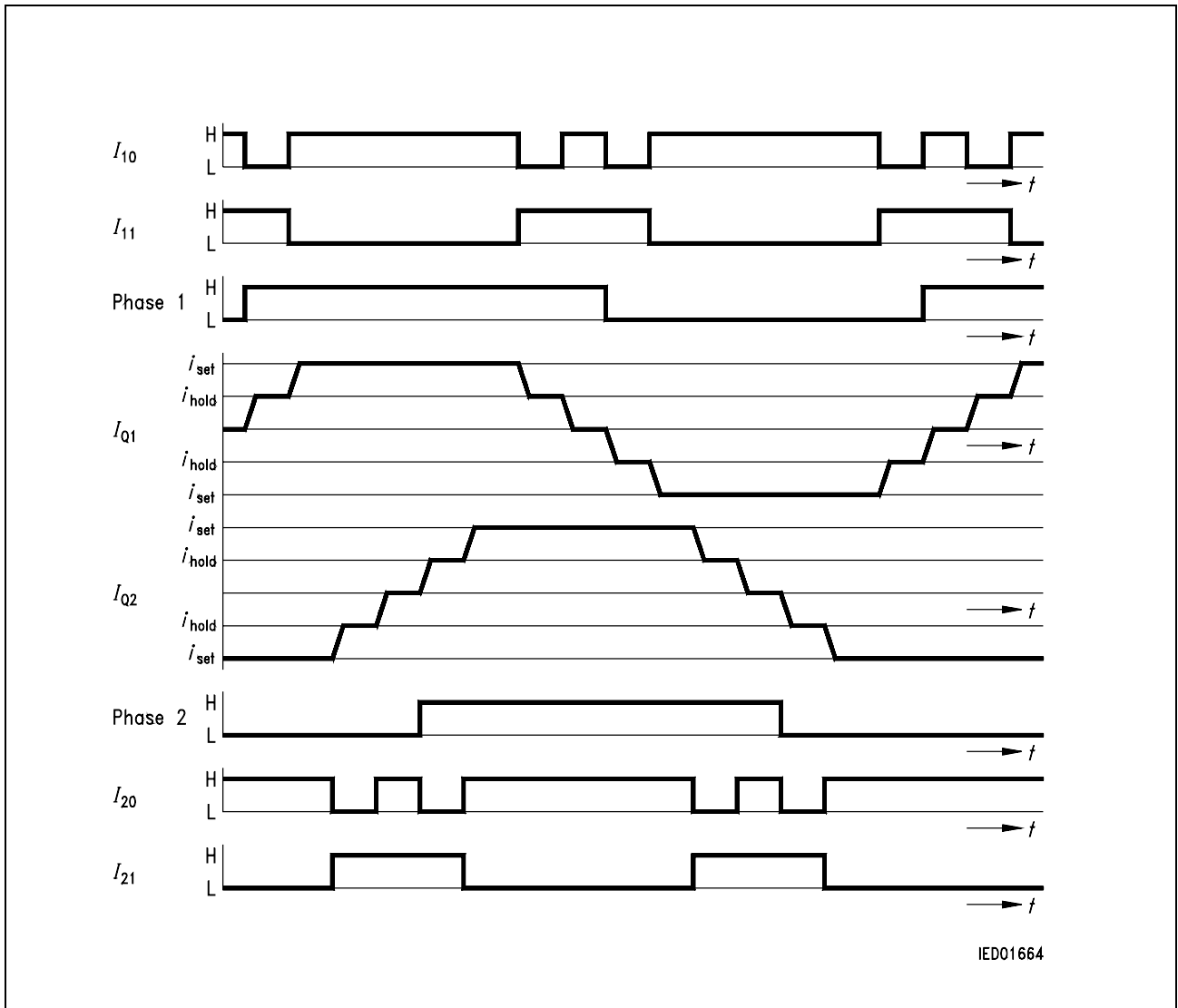

**Figure 7 Full-Step Operation**





**Figure 8 Half-Step Operation**



**Figure 9 Quarter-Step Operation**

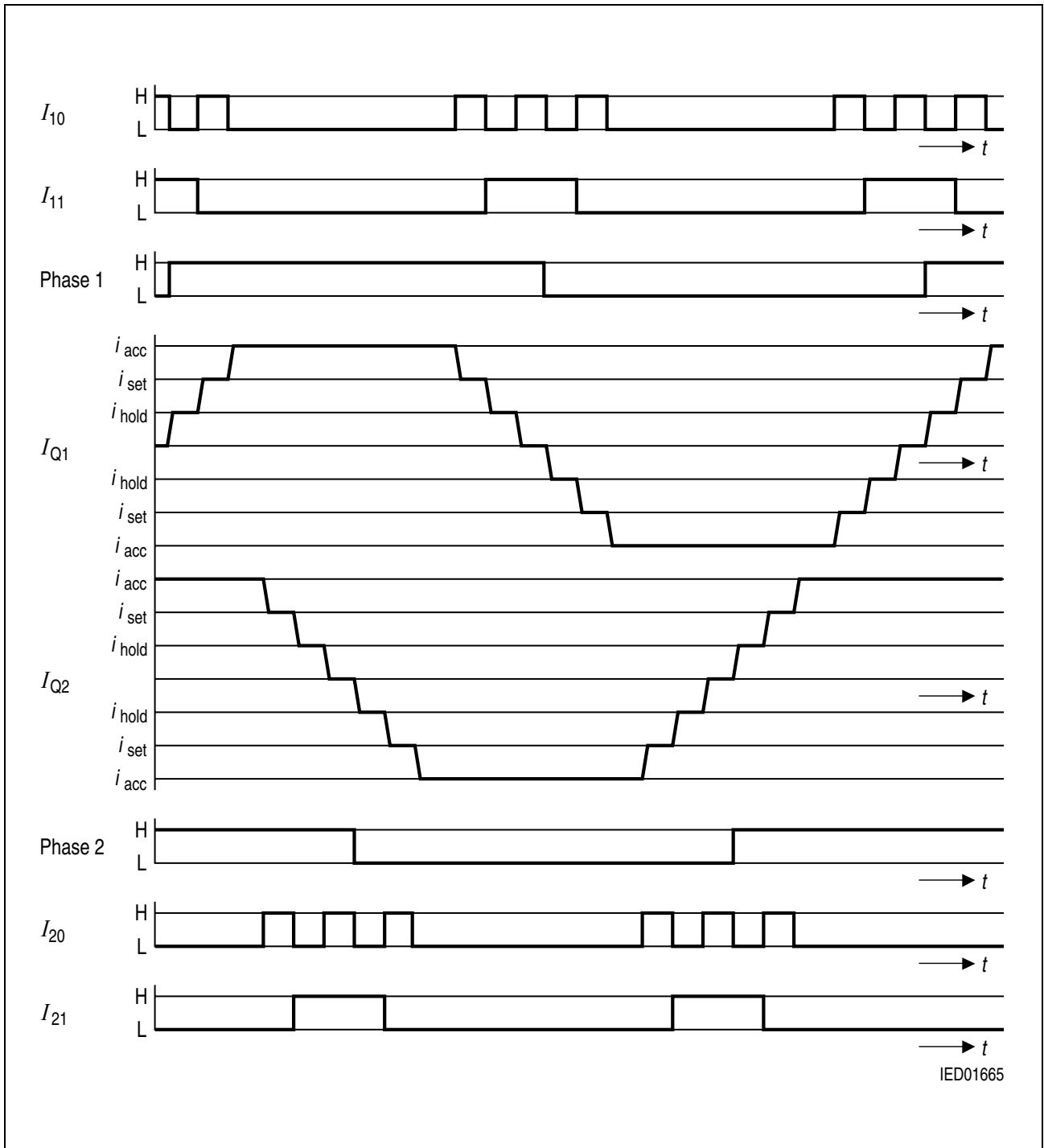
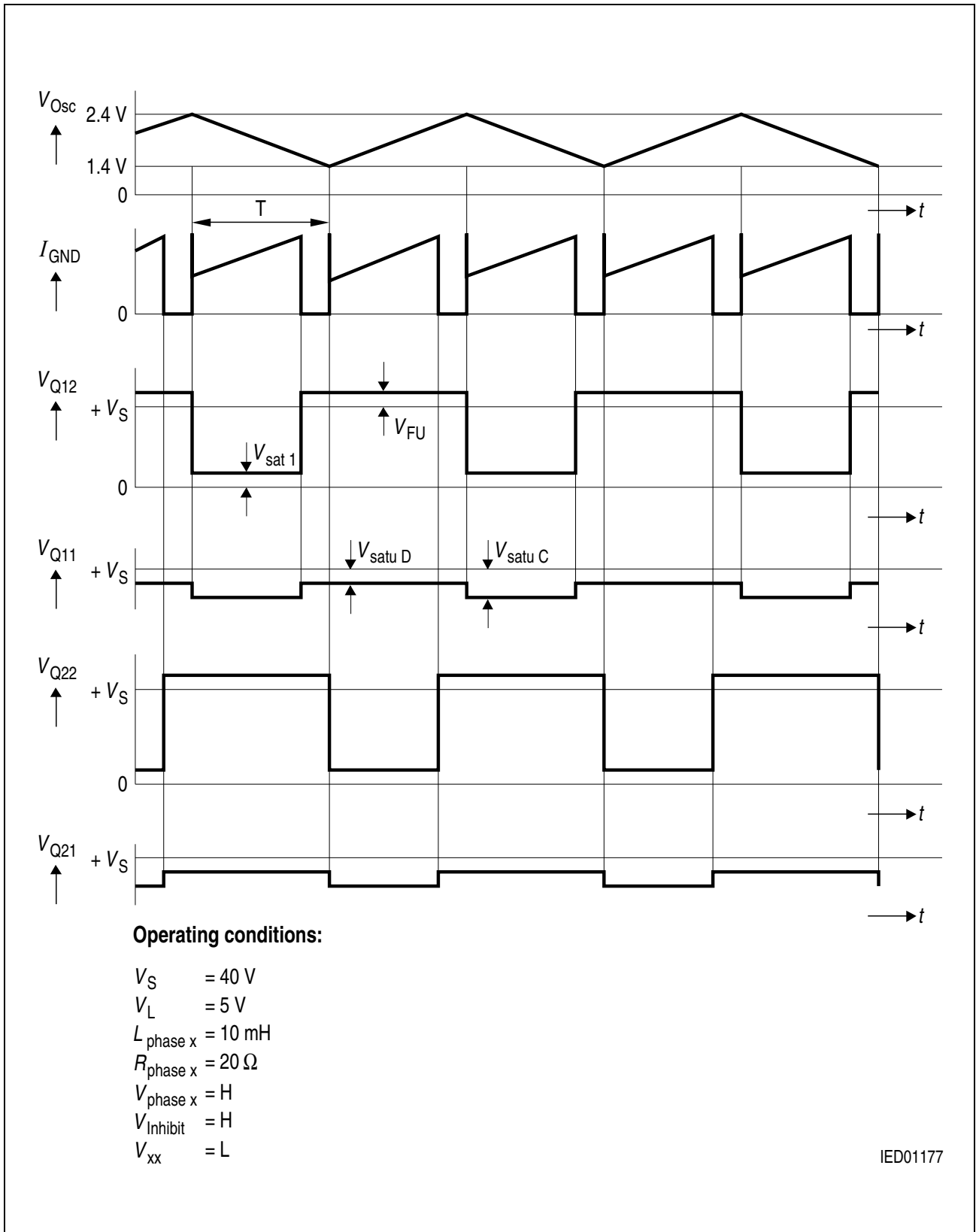

Figure 10 Mini-Step Operation



**Figure 11 Current Control**

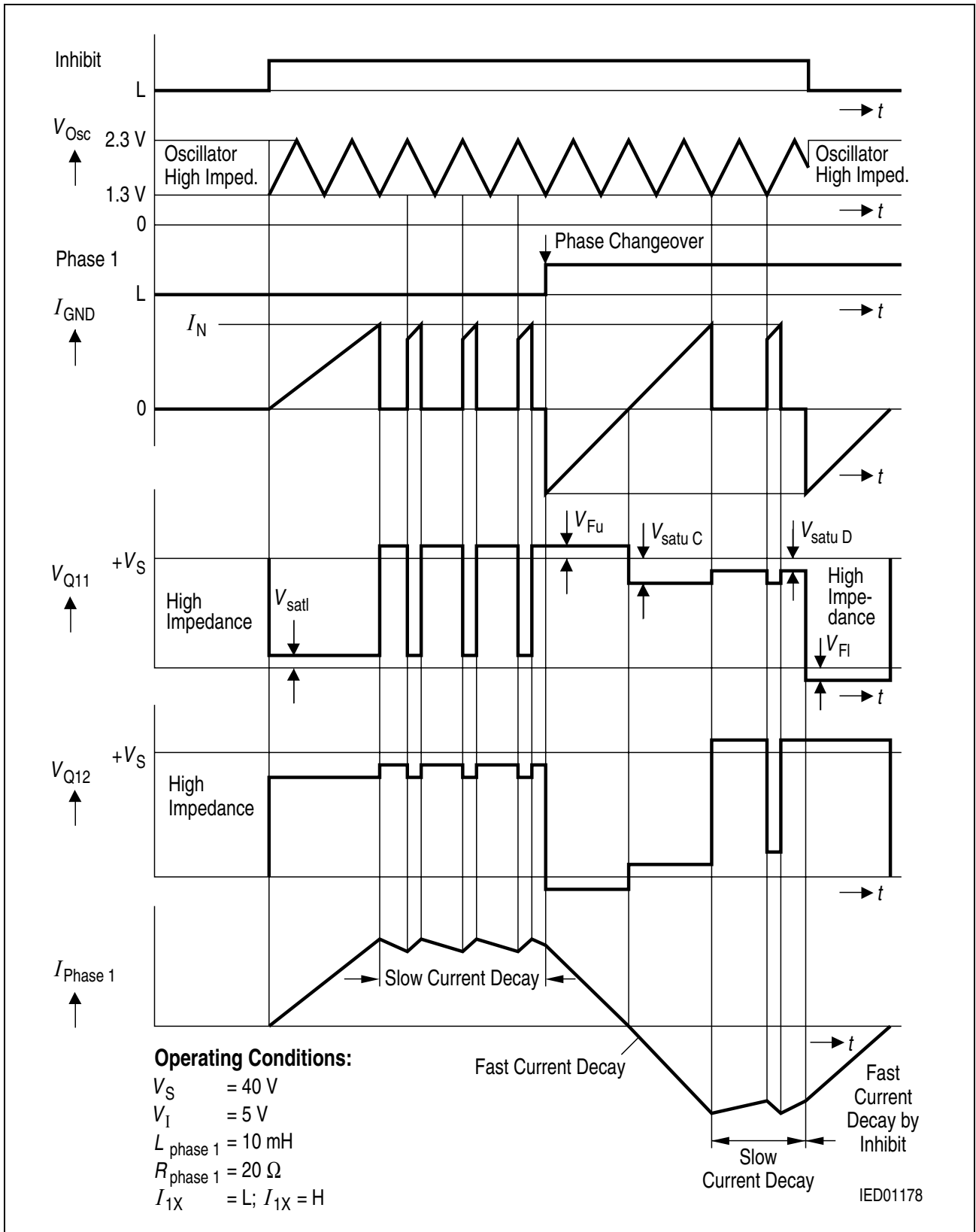

Figure 12 Phase Reversal and Inhibit

## Calculation of Power Dissipation

The total power dissipation  $P_{\text{tot}}$  is made up of

- **saturation losses**  $P_{\text{sat}}$  (transistor saturation voltage and diode forward voltages),
- **quiescent losses**  $P_{\text{q}}$  (quiescent current times supply voltage) and
- **switching losses**  $P_{\text{s}}$  (turn-ON / turn-OFF operations).

The following equations give the power dissipation for chopper operation without phase reversal. This is the worst case, because full current flows for the entire time and switching losses occur in addition.

$$P_{\text{tot}} = 2 \times P_{\text{sat}} + P_{\text{q}} + 2 \times P_{\text{s}} \quad (1)$$

where

- $P_{\text{sat}} \cong I_{\text{N}} \{V_{\text{satI}} \times d + V_{\text{Fu}} (1 - d) + V_{\text{satuC}} \times d + V_{\text{satuD}} (1 - d)\}$
- $P_{\text{q}} = I_{\text{q}} \times V_{\text{S}} + I_{\text{L}} \times V_{\text{L}}$

$$P_{\text{s}} \cong \frac{V_{\text{S}}}{T} \left\{ \frac{i_{\text{D}} \times t_{\text{DON}}}{2} + \frac{i_{\text{D}} + i_{\text{R}} \times t_{\text{ON}}}{4} + \frac{I_{\text{N}}}{2} t_{\text{DOFF}} + t_{\text{OFF}} \right\} \quad (2)$$

- $I_{\text{N}}$  = nominal current (mean value)
- $I_{\text{q}}$  = quiescent current
- $i_{\text{D}}$  = reverse current during turn-on delay
- $i_{\text{R}}$  = peak reverse current
- $t_{\text{p}}$  = conducting time of chopper transistor
- $t_{\text{ON}}$  = turn-ON time
- $t_{\text{OFF}}$  = turn-OFF time
- $t_{\text{DON}}$  = turn-ON delay
- $t_{\text{DOFF}}$  = turn-OFF delay
- $T$  = cycle duration
- $d$  = duty cycle  $t_{\text{p}}/T$
- $V_{\text{satI}}$  = saturation voltage of sink transistor (T3, T4)
- $V_{\text{satuC}}$  = saturation voltage of source transistor (T1, T2) during charge cycle
- $V_{\text{satuD}}$  = saturation voltage of source transistor (T1, T2) during discharge cycle
- $V_{\text{Fu}}$  = forward voltage of free-wheeling diode (D1, D2)
- $V_{\text{S}}$  = supply voltage
- $V_{\text{L}}$  = logic supply voltage
- $I_{\text{L}}$  = current from logic supply

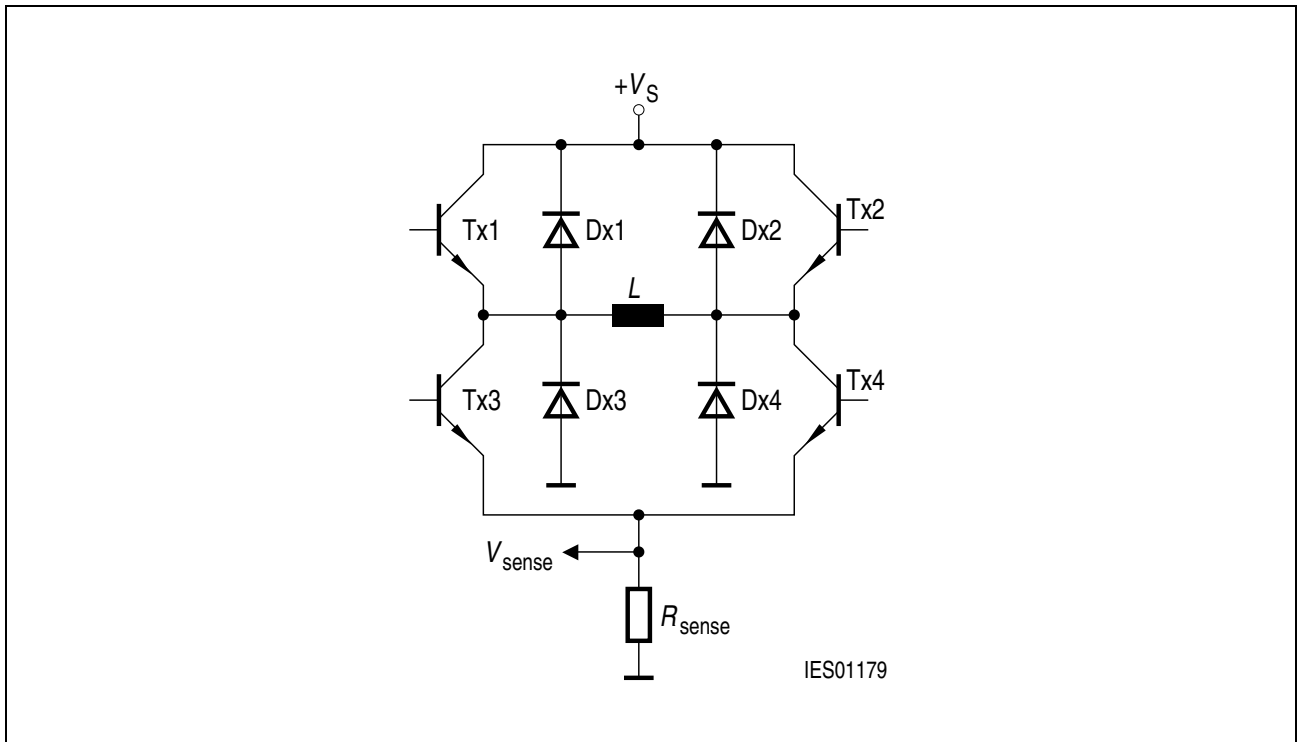

Figure 13

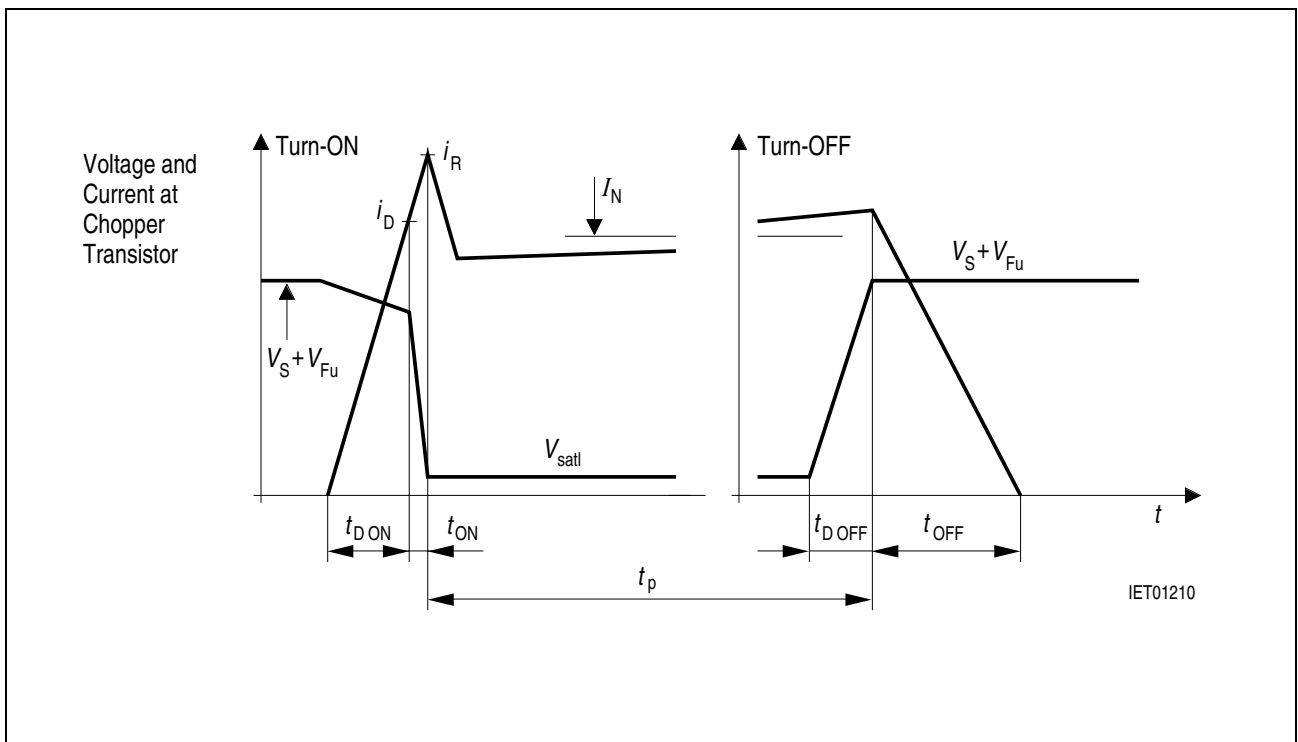

Figure 14

## Application Hints

The TCA 3727 is intended to drive both phases of a stepper motor. Special care has been taken to provide high efficiency, robustness and to minimize external components.

## Power Supply

The TCA 3727 will work with supply voltages ranging from 5 V to 50 V at pin  $V_S$ . As the circuit operates with chopper regulation of the current, interference generation problems can arise in some applications. Therefore the power supply should be decoupled by a 0.22  $\mu$ F ceramic capacitor located near the package. Unstabilized supplies may even afford higher capacities.

## Current Sensing

The current in the windings of the stepper motor is sensed by the voltage drop across  $R_1$  and  $R_2$ . Depending on the selected current internal comparators will turn off the sink transistor as soon as the voltage drop reaches certain thresholds (typical 0 V, 0.25 V, 0.5 V and 0.75 V); ( $R_1, R_2 = 1 \Omega$ ). These thresholds are neither affected by variations of  $V_L$  nor by variations of  $V_S$ .

Due to chopper control fast current rises (up to 10 A/ $\mu$ s) will occur at the sensing resistors  $R_1$  and  $R_2$ . To prevent malfunction of the current sensing mechanism  $R_1$  and  $R_2$  should be pure ohmic. The resistors should be wired to GND as directly as possible. Capacitive loads such as long cables (with high wire to wire capacity) to the motor should be avoided for the same reason.

## Synchronizing Several Choppers

In some applications synchronous chopping of several stepper motor drivers may be desirable to reduce acoustic interference. This can be done by forcing the oscillator of the TCA 3727 by a pulse generator overdriving the oscillator loading currents (approximately  $\geq \pm 100 \mu$ A). In these applications low level should be between 0 V and 1 V while high level should be between 2.6 V and  $V_L$ .

## Optimizing Noise Immunity

Unused inputs should always be wired to proper voltage levels in order to obtain highest possible noise immunity.

To prevent crossconduction of the output stages the TCA 3727 uses a special break before make timing of the power transistors. This timing circuit can be triggered by short glitches (some hundred nanoseconds) at the Phase inputs causing the output stage to become high resistive during some microseconds. This will lead to a fast current decay during that time. To achieve maximum current accuracy such glitches at the Phase inputs should be avoided by proper control signals.



## Thermal Shut Down

To protect the circuit against thermal destruction, thermal shut down has been implemented. To provide a warning in critical applications, the current of the sensing element is wired to input Inhibit. Before thermal shut down occurs Inhibit will start to pull down by some hundred microamperes. This current can be sensed to build a temperature prealarm.

### Package Outlines

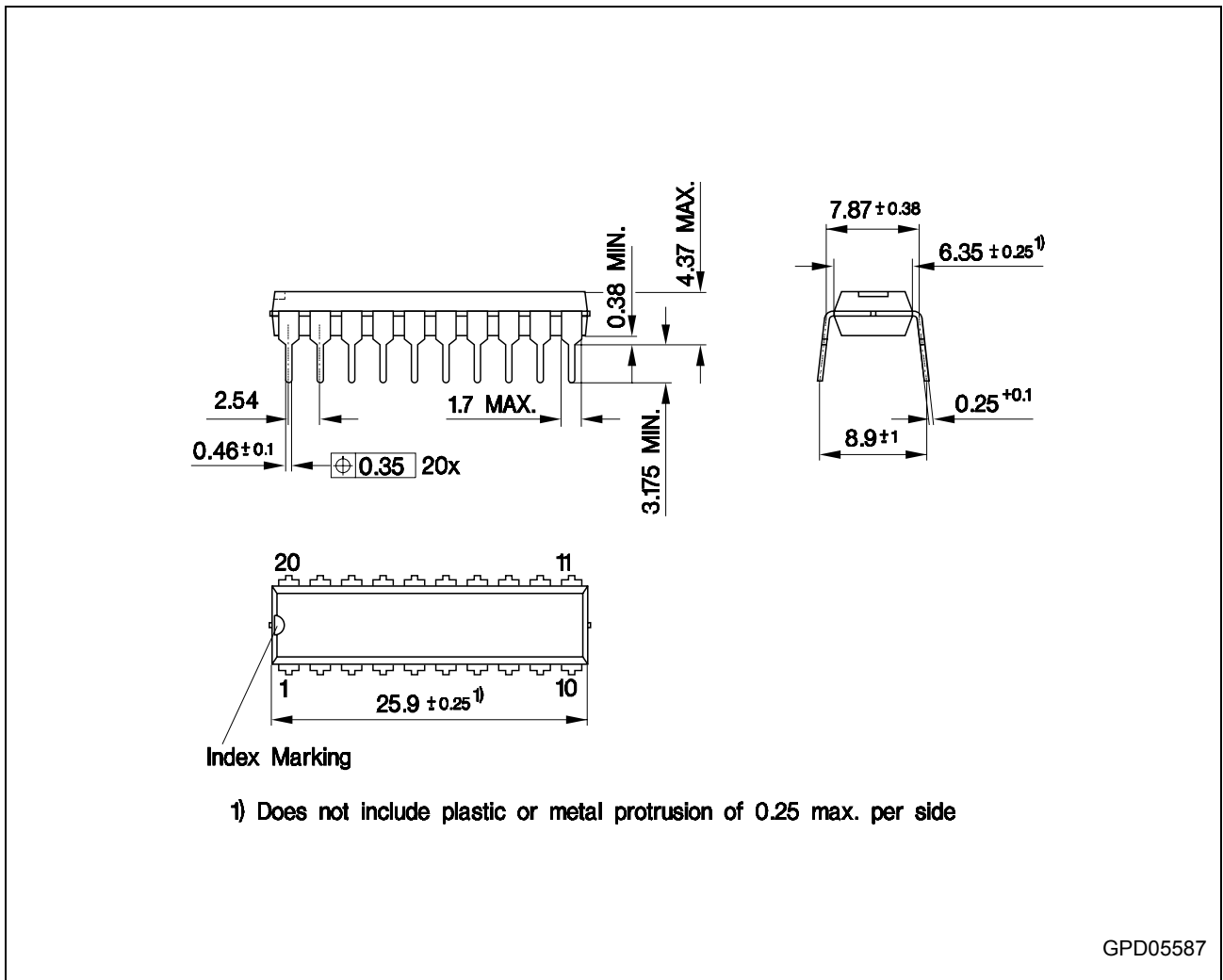

**Figure 15 P-DIP-20-6 (Plastic Dual In-line Package)**

You can find all of our packages, sorts of packing and others in our Infineon Internet Page "Products": <http://www.infineon.com/products>.

Dimensions in mm

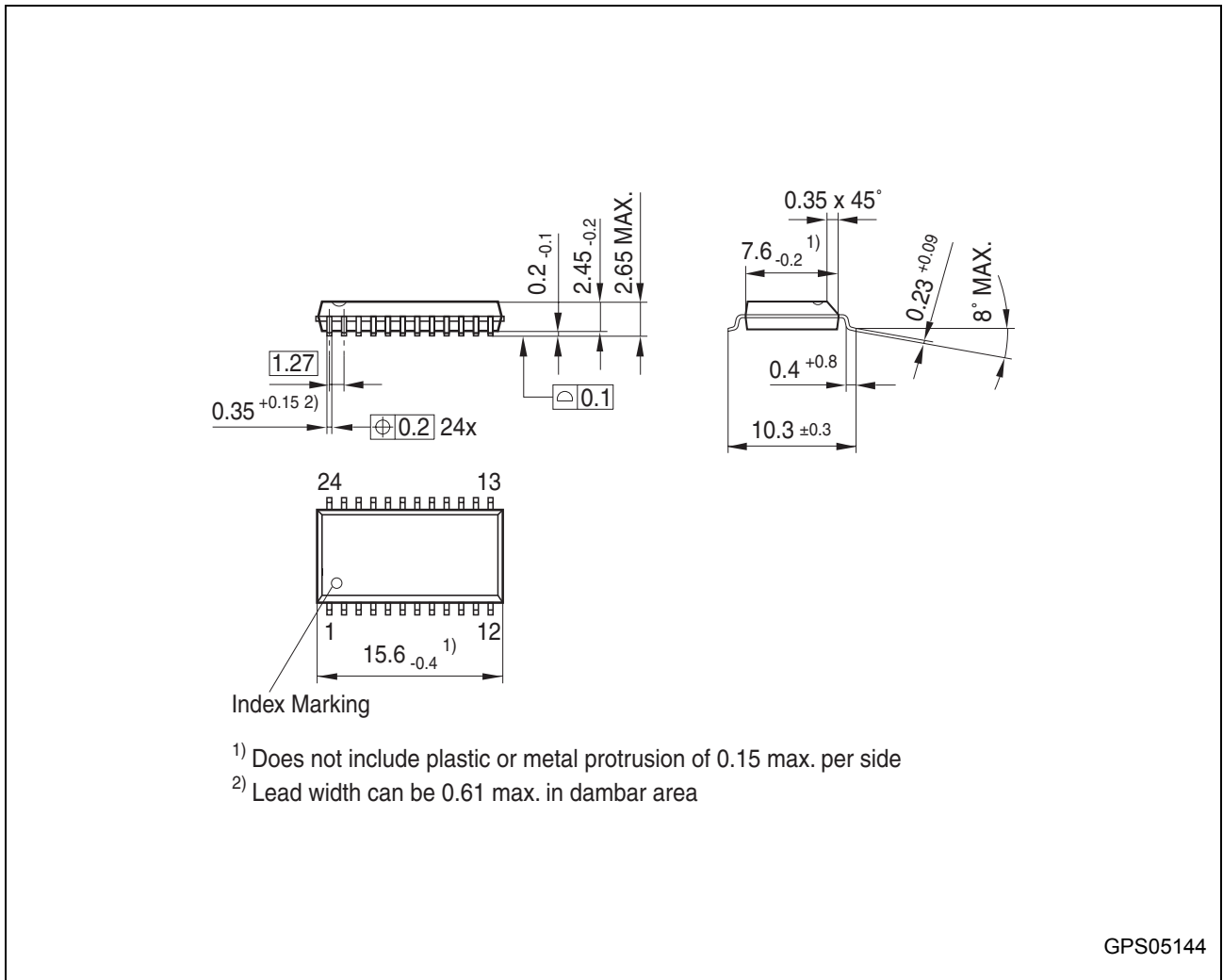

**Figure 16 P-DSO-24-3 (Plastic Dual Small Outline Package)**

You can find all of our packages, sorts of packing and others in our Infineon Internet Page "Products": <http://www.infineon.com/products>.

Dimensions in mm

---

**TCA 3727****Revision History:            2004-10-01**

Rev. 2.0

Previous Version:            1.0, 1998-12-16

Page	Subjects (major changes since last revision)

**Edition 2004-10-01**

**Published by Infineon Technologies AG,  
St.-Martin-Strasse 53,  
81669 München, Germany**

**© Infineon Technologies AG 2004.  
All Rights Reserved.**

**Attention please!**

The information herein is given to describe certain components and shall not be considered as a guarantee of characteristics.

Terms of delivery and rights to technical change reserved.

We hereby disclaim any and all warranties, including but not limited to warranties of non-infringement, regarding circuits, descriptions and charts stated herein.

**Information**

For further information on technology, delivery terms and conditions and prices please contact your nearest Infineon Technologies Office ([www.infineon.com](http://www.infineon.com)).

**Warnings**

Due to technical requirements components may contain dangerous substances. For information on the types in question please contact your nearest Infineon Technologies Office.

Infineon Technologies Components may only be used in life-support devices or systems with the express written approval of Infineon Technologies, if a failure of such components can reasonably be expected to cause the failure of that life-support device or system, or to affect the safety or effectiveness of that device or system. Life support devices or systems are intended to be implanted in the human body, or to support and/or maintain and sustain and/or protect human life. If they fail, it is reasonable to assume that the health of the user or other persons may be endangered.