

The MRFIC Line Integrated GPS Downconverter

This integrated circuit is intended for GPS receiver applications. The dual conversion design is implemented in Motorola's low-cost high performance MOSAIC 3 silicon bipolar process and is packaged in a low-cost surface mount TQFP-48 package. In addition to the mixers, a VCO, a PLL and a loop filter are integrated on-chip. Output IF is nominally 9.5 MHz.

- 65 dB Minimum Conversion Gain
- 5 Volts Operation
- 50 mA Typical Current Consumption
- Low-Cost, Low Profile Plastic LQFP Package
- Order MRFIC1502R2 for Tape and Reel.
R2 Suffix = 1,500 Units per 16 mm, 13 inch Reel.
- Device Marking = M1502

MRFIC1502

**1.575 GHz GPS
DOWNCONVERTER**



**CASE 932-02
(LQFP-48)**

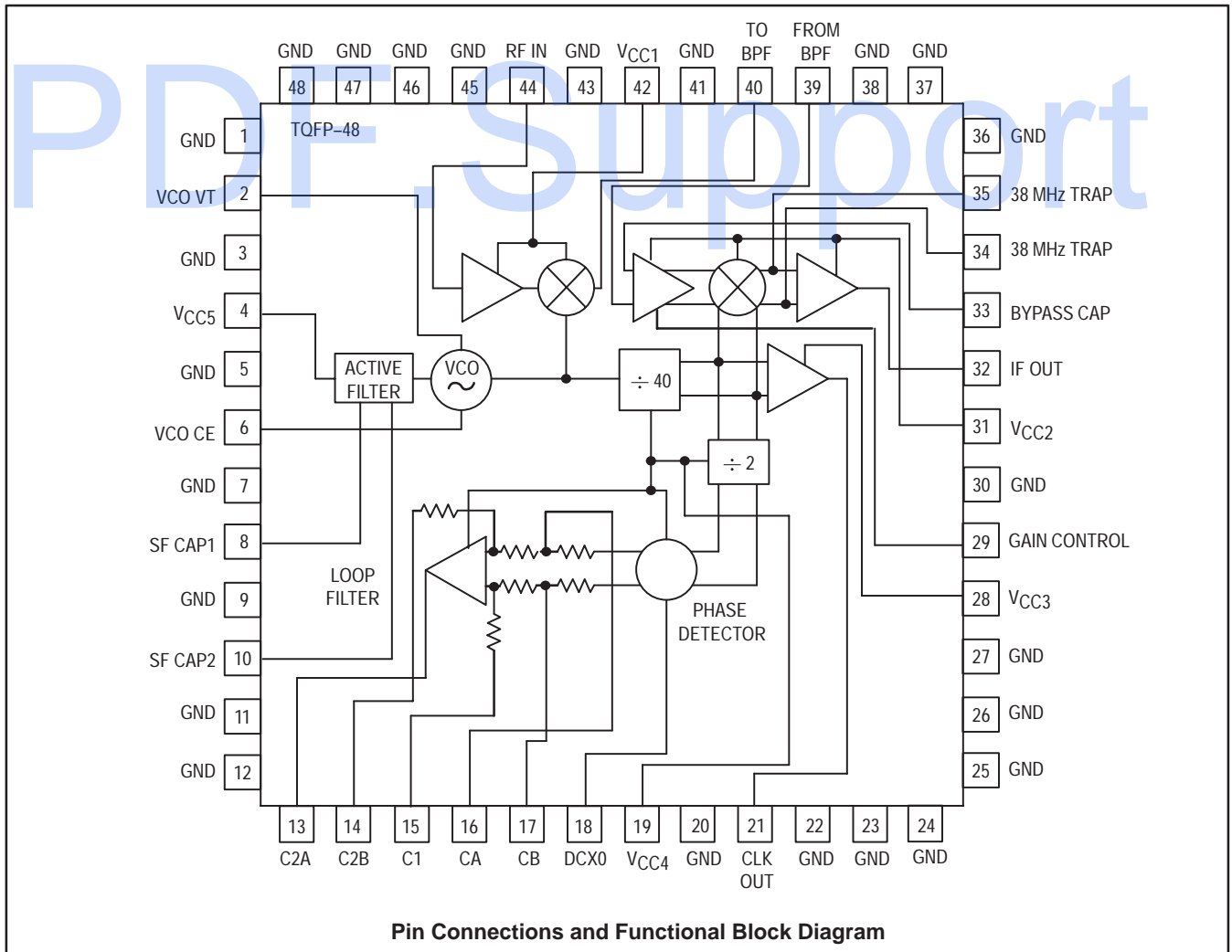

MAXIMUM RATINGS

Rating	Symbol	Limit	Unit
DC Supply Voltage	V_{DD}	+6.0	Vdc
DC Supply Current	I_{DD}	60	mA
Operating Ambient Temperature	T_A	-40 to +100	°C
Storage Temperature Range	T_{stg}	-65 to +150	°C
Lead Soldering Temperature Range (10 seconds)	—	+260	°C

ELECTRICAL CHARACTERISTICS ($T_A = 25^\circ\text{C}$, and $V_{CC} = 5\text{ V}$, Tested in Circuit shown in Figure 1 unless otherwise noted)

Characteristic	Min	Typ	Max	Unit
Supply Voltage	4.75	—	5.25	Vdc
Supply Current	—	—	60	mA
L-Band Gain (Measured from L-Band Input to 47 MHz Output)	—	20	—	dB
IF Gain (Measured from 47 MHz Input to 9.5 MHz Output with Gain Control at Maximum)	—	45	—	dB
Conversion Gain (Measured from L-Band Input to 9.5 MHz Output with Gain Control at Maximum)	65	—	—	dB
Gain Control (Externally Adjustable 0 to 5.0 V, Maximum at 0 V)	—	40	—	dB
Noise Figure (Double Sideband)	—	9.5	—	dB
L-Band Input VSWR (Measured into 50 Ω ; 1575.42 \pm 5.0 MHz)	—	2:1	—	—
First IF Output VSWR (Measured into 50 Ω ; 47.74 \pm 5.0 MHz)	—	2:1	—	—
Second IF Output VSWR (Measured into 50 Ω ; 9.5 \pm 5.0 MHz)	—	2:1	—	—
Input Impedance @ 1st IF 47.7 \pm 5 MHz (For Reference Only)	—	2000	—	Ω
Output 1.0 dB Compression Point	—	-7	—	dBm
First LO (Measured at the First IF Output)	—	-20	—	dBm
All Other Harmonics (Measured at the First IF Output)	—	-45	—	dBm
38.1915 MHz Leakage at First IF Output	—	-50	—	dBm
Second LO (Measured at the Second IF Output)	—	-25	—	dBm
All Other Harmonics (Measured at Second IF Output)	—	-45	—	dBm
Reference Oscillator Input	400	—	4500	mVpp
Clock Output Frequency	$2X_{fref}$	—	$2X_{fref}$	
Clock Output Amplitude Low	—	—	0.8	V
Clock Output Amplitude High	2.0	—	—	V
(Clock Amplitude Measured with the Output Loaded in 15 pF and 40 k Ω) Duty Cycle	45	—	55	%
VCO Lock Voltage	1.2	—	3.0	V
Phase Detector Gain	—	0.16	—	V/Radian
VCO Modulation Sensitivity	—	15	—	MHz/V

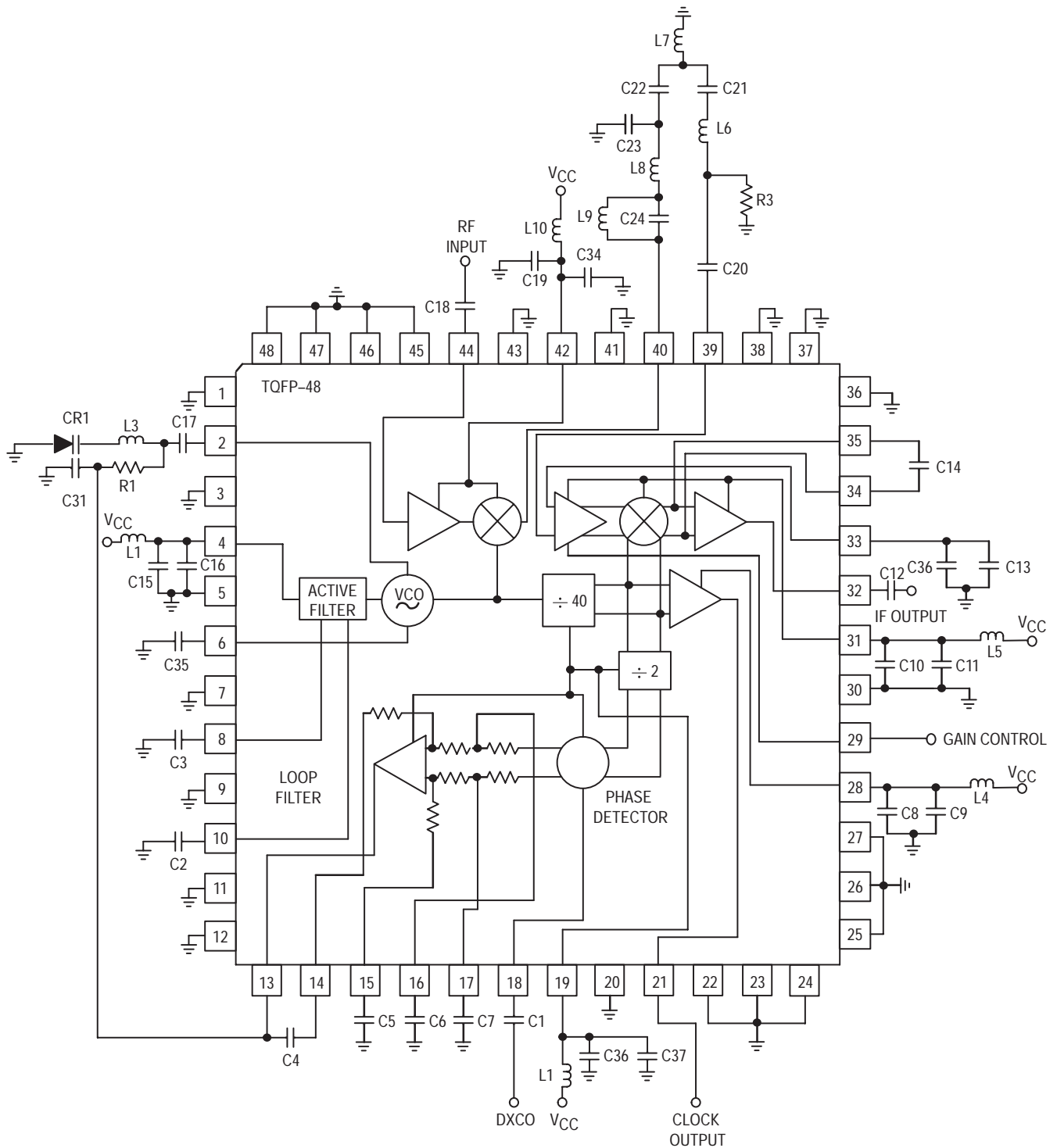

C1, C8, C10, C12, C13, C15,		C24	68 pF, ATC
C19, C20, C37	10,000 pF	C35	1.0 pF, ATC*
C4, C5	5600 pF	CR1	2.7 pF, MA45233-123, MACOM
C6, C7, C31	1000 pF	L1, L4, L5, L10	2.2 μH, 1008CS-222XKBC, COILCRAFT
C2, C3	1.0 μF	L3	2.2 nH, LL2012-F2N2S, TOKO
C14	3.9 pF, ATC	L6	2.2 μH
C16, C18, C36	27 pF, ATC	L7	220 nH
C17	15 pF, ATC	L8	0.56 μH
C21	5.6 pF, ATC	L9	0.27 μH
C9, C11, C34, C36	47 pF, ATC	R1	10 kΩ
C22, C23	120 pF, ATC	R3	220 Ω

* See Application Information on following pages for importance of emitter capacitance

Figure 1. Test Circuit Configuration

Table 1. Port Impedance Derived from Circuit Characterization

Pin Number	Pin Name	f (MHz)	Z _{in} Ohms	
			R	jX
44	RF IN	1575.42	38.3	-16.09
40	TO BPF	47.74	54.45	11.3
39	FROM BPF	47.74	43	1.5
32	IF OUT	9.5	560	-850

Z_{in} represents the input impedance of the pin.

APPLICATION INFORMATION

Design Philosophy

The MRFIC1502 design is a standard dual downconversion configuration with an integrated fixed frequency phase-locked loop to generate the two local oscillators and the buffer to generate the sampling clock for a digital correlator and decimator. The active device for the L-band VCO is also integrated on the chip. This chip is designed in the third generation of Motorola's Oxide Self Aligned Integrated Circuits (MOSAIC 3) silicon bipolar process.

Circuit Considerations

The RF input to the MRFIC1502 is internally matched to 50 ohms. Therefore, only AC coupling is required on the input. The output of the amplifier is fed directly into the first mixer. This mixer is an active Gilbert Cell configuration. The output of the mixer is brought off-chip for filtering of the unwanted mixer products. The amplifier and mixer have their own V_{CC} supply (pin 42) in order to reduce the amount of coupling to the other circuits. There are two bypass capacitors on this pin, one for the high frequency components and one for the lower frequency components. These two capacitors should be placed physically as close to the bias pin as possible to reduce the inductance in the path. The capacitors should also be grounded as close to the ground of the IC as possible, preferably through a ground plane.

The output impedance of the first mixer is 50 ohms, while the input impedance to the first IF amplifier is 1 kΩ. There is a trap (zero) designed in at the second LO frequency to limit the amount of LO leakage into the high gain first IF amplifier.

The first IF amplifier is a variable gain amplifier with 25 dB of gain and 40 dB of gain control. The gain control pin can be grounded to provide the maximum gain out of the amplifier. If the baseband design utilizes a multi-bit A/D converter in the digital signal processing chip, this amplifier could be used to control the input to the A/D converter. The amplifier has an external bypassing capacitor. This capacitor should be on the order of 0.01 μF, and again should be located near the package pin.

The second mixer design is also a Gilbert Cell configuration. The interface between the mixer and the second IF amplifier is differential in order to increase noise immunity. This differential interface is also brought off-chip so that some additional filtering could be added in parallel between the output of the mixer and input to the amplifier.

This filtering is primarily to reduce the amount of LO leakage into the final IF amplifier and is achieved using a single 3.9 pF capacitor across the differential ports. The value of the capacitor determines the high frequency of the low pass structure.

The supply pin for the IF circuits is pin 33. This supply pin should be isolated from the other chip supplies in order to reduce the amount of coupling. The recommended capacitors are a 47 pF and a 0.01 μF, in parallel to bypass the supply to ground and should be placed physically as close to the pin as possible.

The output of the second IF amplifier is 50 ohms with a bandwidth of ±5.0 MHz. This signal must be filtered before being digitized in order to limit the noise entering the A/D converter.

VCO Resonator Design

The design and layout of the circuits around the voltage controlled oscillator (VCO) are the most sensitive of the entire layout. The active device and biasing resistors are integrated on the MRFIC1502. The external circuits consist of the power supply decoupling, the capacitors for the integrated supply superfilter, the resonator and frequency adjusting elements, and the bypassing capacitor on the emitter of the active device.

The VCO supply is isolated from the rest of the PLL circuits in order to reduce the amount of noise that could cause frequency/phase noise in the VCO. The supply should be filtered using a 22 μH inductor in series and a 27 pF and 0.01 μF in parallel. The 27 pF capacitor should be series resonant at least as high as the VCO frequency to get the most L-band bypassing as possible. The on-chip supply filter requires two capacitors off-chip to filter the supply. The capacitors on the input (pin 8) and output (pin 10) of the filter are 1.0 μF, and the output also has a high frequency bypass capacitor in parallel. The input capacitor should not be smaller than a 1.0 μF to insure stability of the supply filter.

The VCO design is a standard negative resistance cell with a buffer amplifier. The resonating structure is connected to the base of the active device and consists of a coupling capacitor, a hyper-abrupt varactor diode, and a wire wound chip inductor. With the values shown on the application

circuit, the VCO is centered at 1527.7 MHz, and the gain of the VCO is approximately 20 MHz/Volt.

The above performance is heavily dependent on the capacitive structure that is used as the emitter bypass on pin 6. The total capacitance should be 1.0 pF; that can be achieved using either a discrete element or a microstrip open circuited stub. The evaluation circuit shown uses a 1.0 pF capacitor.

Phase-locked Loop Design

The VCO signal at 1527.68 MHz is divided by 40 to get the second LO frequency of 38.19 MHz. In addition to providing the LO to the second mixer, the 38 MHz signal is output through a translator and is used as the sampling clock for the digital correlator and decimator circuits. There is an additional divide by two so the signal used by the phase detector is at 19.096 MHz. The reference input to the phase detector (pin 18) has an input sensitivity of 400 mVpp minimum and 2.5 Vpp maximum.

The loop filter design is the standard op-amp loop filter, resulting in a type 2 second order loop. The layout of the

discrete components around the loop filter and VCO is very critical to the performance of the phase-locked loop. Care should be taken in routing the VCO control voltage line from the output of the loop filter to the varactor diode.

The output of the divide by 40 is buffered by a clock translator that converts the low level sine wave into a TTL level square wave. The loading on the buffer is high so the peak currents can reach as high as 50 mA with the maximum load of 1.0 k Ω in parallel with 40 pF on the output. Therefore, the translator has a dedicated V_{CC} supply, pin 28, which requires external bypassing and isolation. The recommended bypassing uses two capacitors in parallel, a 47 pF and a 0.01 μ F capacitor.

Conclusion

The MRFIC1502 offers a highly integrated downconverter solution for GPS receivers. For more detailed applications information on GPS system design refer to application note AN1610, "Using Motorola's MRFIC1502 in Global Positioning System Receivers."

PACKAGE DIMENSIONS

PLASTIC PACKAGE
CASE 932-03
(LQFP-48)
ISSUE F

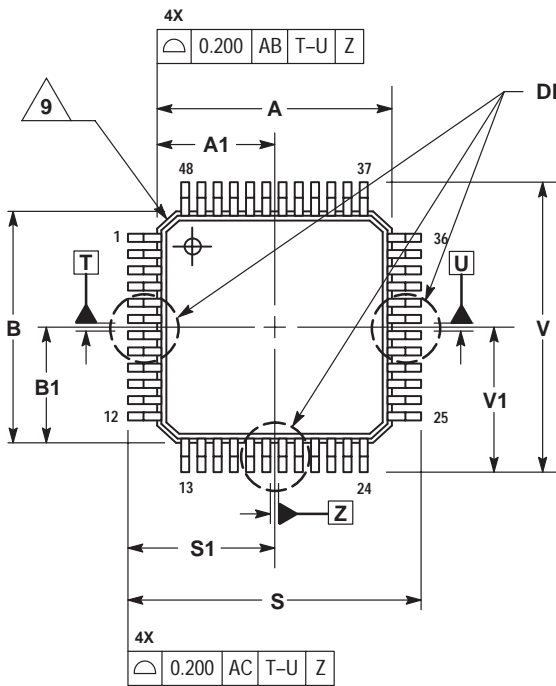

DETAIL Y

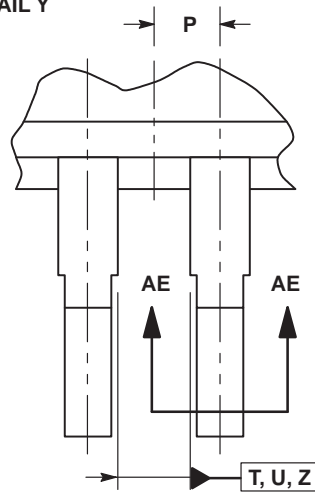

DETAIL Y

NOTES:

1. DIMENSIONING AND TOLERANCING PER ASME Y14.5M, 1994.
 2. CONTROLLING DIMENSION: MILLIMETER.
 3. DATUM PLANE AB IS LOCATED AT BOTTOM OF LEAD AND IS COINCIDENT WITH THE LEAD WHERE THE LEAD EXITS THE PLASTIC BODY AT THE BOTTOM OF THE PARTING LINE.
 4. DATUMS T, U, AND Z TO BE DETERMINED AT DATUM PLANE AB.
 5. DIMENSIONS S AND V TO BE DETERMINED AT SEATING PLANE AC.
 6. DIMENSIONS A AND B DO NOT INCLUDE MOLD PROTRUSION. ALLOWABLE PROTRUSION IS 0.250 PER SIDE. DIMENSIONS A AND B DO INCLUDE MOLD MISMATCH AND ARE DETERMINED AT DATUM PLANE AB.
 7. DIMENSION D DOES NOT INCLUDE DAMBAR PROTRUSION. DAMBAR PROTRUSION SHALL NOT CAUSE THE D DIMENSION TO EXCEED 0.350.
 8. MINIMUM SOLDER PLATE THICKNESS SHALL BE 0.0076.
- △ EXACT SHAPE OF EACH CORNER IS OPTIONAL.

MILLIMETERS		
DIM	MIN	MAX
A	7.000	BSC
A1	3.500	BSC
B	7.000	BSC
B1	3.500	BSC
C	1.400	1.600
D	0.170	0.270
E	1.350	1.450
F	0.170	0.230
G	0.500 BSC	
H	0.050	0.150
J	0.090	0.200
K	0.500	0.700
L	0°	7°
M	12° REF	
N	0.090	0.160
P	0.250 BSC	
R	0.150	0.250
S	9.000 BSC	
S1	4.500 BSC	
V	9.000 BSC	
V1	4.500 BSC	
W	0.200 REF	
AA	1.000 REF	

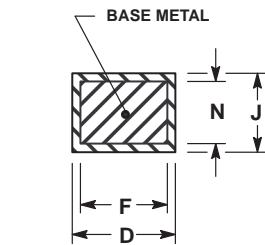
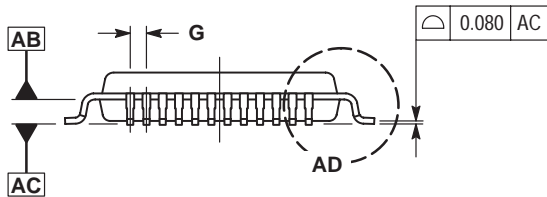

SECTION AE-AE

0.080 M AC T-U Z

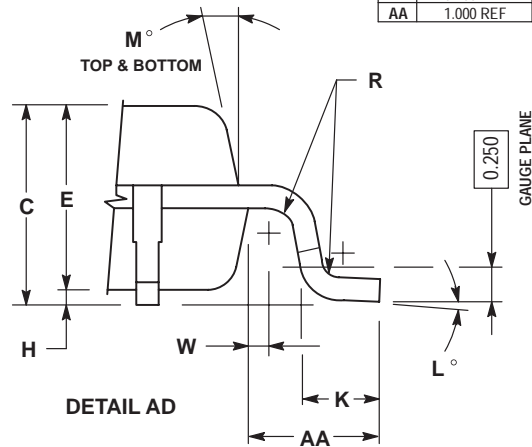

DETAIL AD

NOTES

Motorola reserves the right to make changes without further notice to any products herein. Motorola makes no warranty, representation or guarantee regarding the suitability of its products for any particular purpose, nor does Motorola assume any liability arising out of the application or use of any product or circuit, and specifically disclaims any and all liability, including without limitation consequential or incidental damages. "Typical" parameters which may be provided in Motorola data sheets and/or specifications can and do vary in different applications and actual performance may vary over time. All operating parameters, including "Typicals" must be validated for each customer application by customer's technical experts. Motorola does not convey any license under its patent rights nor the rights of others. Motorola products are not designed, intended, or authorized for use as components in systems intended for surgical implant into the body, or other applications intended to support or sustain life, or for any other application in which the failure of the Motorola product could create a situation where personal injury or death may occur. Should Buyer purchase or use Motorola products for any such unintended or unauthorized application, Buyer shall indemnify and hold Motorola and its officers, employees, subsidiaries, affiliates, and distributors harmless against all claims, costs, damages, and expenses, and reasonable attorney fees arising out of, directly or indirectly, any claim of personal injury or death associated with such unintended or unauthorized use, even if such claim alleges that Motorola was negligent regarding the design or manufacture of the part. Motorola and  are registered trademarks of Motorola, Inc. Motorola, Inc. is an Equal Opportunity/Affirmative Action Employer.

How to reach us:

USA/EUROPE/Locations Not Listed: Motorola Literature Distribution;
P.O. Box 5405, Denver, Colorado 80217. 1-303-675-2140 or 1-800-441-2447

JAPAN: Motorola Japan Ltd.; SPS, Technical Information Center, 3-20-1,
Minami-Azabu, Minato-ku, Tokyo 106-8573 Japan. 81-3-3440-3569

Technical Information Center: 1-800-521-6274

ASIA/PACIFIC: Motorola Semiconductors H.K. Ltd.; Silicon Harbour Centre,
2, Dai King Street, Tai Po Industrial Estate, Tai Po, N.T., Hong Kong.
852-26668334

HOME PAGE: <http://www.motorola.com/semiconductors/>

