



Sine-wave filter and output reactor Output filters for frequency converters

System Manual

<u>Introduction</u>	1
<u>Product line</u>	2
<u>Product combination</u>	3
<u>Functions</u>	4
<u>Application planning</u>	5
<u>Installation</u>	6
<u>Connection</u>	7
<u>Commissioning</u>	8
<u>Maintenance and servicing</u>	9
<u>Technical specifications</u>	10
<u>Circuit diagrams</u>	11
<u>List of abbreviations</u>	A

Safety Guidelines

This manual contains notices you have to observe in order to ensure your personal safety, as well as to prevent damage to property. The notices referring to your personal safety are highlighted in the manual by a safety alert symbol, notices referring only to property damage have no safety alert symbol. These notices shown below are graded according to the degree of danger.

 DANGER
indicates that death or severe personal injury will result if proper precautions are not taken.
 WARNING
indicates that death or severe personal injury may result if proper precautions are not taken.
 CAUTION
with a safety alert symbol, indicates that minor personal injury can result if proper precautions are not taken.
CAUTION
without a safety alert symbol, indicates that property damage can result if proper precautions are not taken.
NOTICE
indicates that an unintended result or situation can occur if the corresponding information is not taken into account.

If more than one degree of danger is present, the warning notice representing the highest degree of danger will be used. A notice warning of injury to persons with a safety alert symbol may also include a warning relating to property damage.

Qualified Personnel

The device/system may only be set up and used in conjunction with this documentation. Commissioning and operation of a device/system may only be performed by **qualified personnel**. Within the context of the safety notes in this documentation qualified persons are defined as persons who are authorized to commission, ground and label devices, systems and circuits in accordance with established safety practices and standards.

Prescribed Usage

Note the following:

 WARNING
This device may only be used for the applications described in the catalog or the technical description and only in connection with devices or components from other manufacturers which have been approved or recommended by Siemens. Correct, reliable operation of the product requires proper transport, storage, positioning and assembly as well as careful operation and maintenance.

Trademarks

All names identified by ® are registered trademarks of the Siemens AG. The remaining trademarks in this publication may be trademarks whose use by third parties for their own purposes could violate the rights of the owner.

Disclaimer of Liability

We have reviewed the contents of this publication to ensure consistency with the hardware and software described. Since variance cannot be precluded entirely, we cannot guarantee full consistency. However, the information in this publication is reviewed regularly and any necessary corrections are included in subsequent editions.

Table of contents

1	Introduction	5
1.1	Structure and content of the manual.....	5
1.2	Laws and directives	6
2	Product line	7
2.1	Components.....	7
2.2	Device description.....	9
3	Product combination	11
3.1	Functional optimization	11
4	Functions	13
4.1	Method of operation	13
5	Application planning	15
5.1	Configuration.....	15
5.2	EMC-compliant configuration of drive systems.....	16
6	Installation	23
6.1	Assembly.....	23
6.2	Installation instructions.....	29
7	Connection	31
7.1	Prerequisites and definitions.....	31
7.2	Connection options	32
8	Commissioning	37
8.1	Operation	37
9	Maintenance and servicing	39
9.1	Service/Maintenance	39
10	Technical specifications	41
10.1	Rating data.....	41
10.2	Deviation in the rated values at installation altitudes > 1000 m.....	43
11	Circuit diagrams	45
11.1	Circuit diagrams	45
A	List of abbreviations	47
A.1	List of abbreviations	47
	Index	49

Figures

Figure 5-1	Configuration	15
Figure 5-2	Mounting on mounting plate.....	16
Figure 5-3	Shield connection of motor cables inside control cabinet	17
Figure 6-1	Mounting position - output reactors.....	24
Figure 7-1	Protective conductor connection via terminal studs (output reactor).....	32
Figure 7-2	Protective conductor connection via terminal studs (sine-wave filter)	32
Figure 7-3	Protective conductor connection via clip on the angle bracket (output reactor)	33
Figure 7-4	Protective conductor connection via clip on the angle bracket (sine-wave filter)	33
Figure 7-5	Connection - terminal output reactor.....	34
Figure 7-6	Connection terminal - sine-wave filter	35
Figure 7-7	Flat connection.....	36
Figure 8-1	Connection - sine-wave filter	38

Introduction

1.1 Structure and content of the manual

Purpose of the manual

This manual contains all the information required for connecting and using sine-wave filters and output reactors. Sine-wave filters and output reactors are components for converters.

This manual describes EMC-compatible connection and the functions of sine-wave filters and output reactors.

Target group

This manual is intended for any user involved in:

- Commissioning
- Servicing and maintaining
- Planning and configuring systems

Required basic knowledge

A general knowledge of the field of electrical engineering is required to understand this manual.

Standards and approvals

The standard applied for sine-wave filters and output reactors is EN 61558.

Correction sheet

The Appendix contains a correction sheet. Please use it to record your suggestions for improvements, additions and corrections, and return the sheet to us. This will help us to improve the next edition of the manual.

1.2 Laws and directives

Disclaimer of liability

It is the responsibility of the manufacturer to ensure that a system or machine is functioning properly as a whole. SIEMENS AG, its regional offices, and associated companies (hereinafter referred to as "SIEMENS") cannot guarantee all the properties of a whole plant system or machine that has not been designed by SIEMENS.

Nor can SIEMENS assume liability for recommendations that appear or are implied in the following description. No new guarantee, warranty, or liability claims beyond the scope of the SIEMENS general terms of supply are to be derived or inferred from the following description.

Product line

2.1 Components

Reactors and filters

SIDAC reactors and filters are drive components. SIDAC reactors and filter components are used with AC and DC drives.

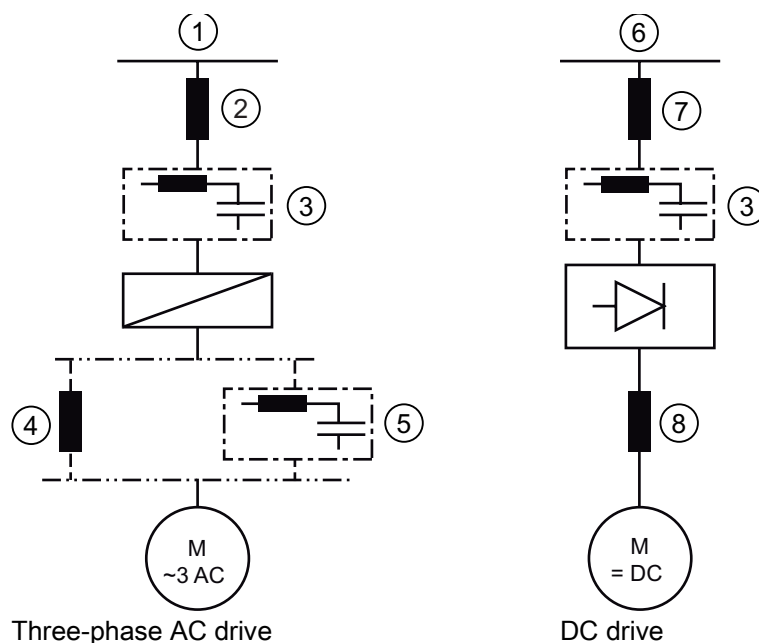

- (1) AC drive 3-ph. supply
- (2) Line reactor
- (3) RFI suppression filter
- (4) Output reactor
- (5) Sine-wave filter
- (6) DC drive 3-ph. supply
- (7) Commutating reactor
- (8) Smoothing reactor

SIDAC line reactors/commutating reactors

SIDAC line reactors and commutating reactors have the following properties:

- SIDAC line reactors/commutating reactors are installed upstream of the DC drive or three-phase AC drive.
- Line reactors/commutating reactors reduce the proportion of low-frequency harmonics on the line, thereby improving the power factor.
- Line reactors/commutating reactors avoid mutual interference caused by low-frequency noise and protect the converter input. The capacitive DC link of frequency converters is protected.

SIDAC RFI suppression filters

SIDAC RFI suppression filters have the following properties:

- SIDAC RFI suppression filters are installed upstream of the DC drive or three-phase AC drive.
- SIDAC RFI suppression filters damp and limit conducted high-frequency (> 150 kHz to 30 MHz) interference voltages.
- RFI suppression filters avoid mutual interference caused by high-frequency interference currents.

SIDAC output reactors and sine-wave filters

SIDAC output reactors and sine-wave filters have the following properties:

- SIDAC output reactors and SIDAC sine-wave filters are installed downstream of the three-phase AC drive (frequency converter).
- SIDAC output reactors and SIDAC sine-wave filters increase the service life of the motor and improve system reliability.

SIDAC smoothing reactors

SIDAC smoothing reactors have the following properties:

- SIDAC smoothing reactors are used in the load circuit of DC drives.
- SIDAC smoothing reactors reduce the harmonic content for the DC motor as well as the rate of current rise, thereby enabling use of DC high-speed circuit breakers.

2.2 Device description

Device versions

The output filters are offered in three-phase design in degree of protection IP00. All sine-wave filters are equipped with safe-to-touch terminals, for the output reactors the 4EP types are equipped with safe-to-touch terminals, and the 4EU types are equipped with flange connections.

Application

Sine-wave filters and output reactors are used on the load side of frequency converters and the motor currents flow through these components. They enable use of shielded motor cables 200 m in length and non-shielded motor cables that are 300 meters in length.

Sine-wave filters filter the frequency converter output variables and thus simulate line-like conditions for the motor. They ensure that the motor is supplied with nearly sinusoidal currents and voltages. This reduces motor losses and magnetic motor noise levels.

Output reactors compensate capacitive switching currents and limit the voltage rate of rise on the motor terminals.

See section 8.1 Operation, for general use conditions.

EMC regulations

Compliance with EMC regulations must be ensured in individual cases by means of an application-specific measurement. The converter's rating data must be taken into account when selecting a filter.

Discharging the capacitors (for sine-wave filters)

Ensure that the energy stored in the capacitors of the sine-wave filters can be quickly reduced, so that the voltage at the terminals drops to within permissible levels.

 WARNING
It must be verified that the disconnected sine-wave filter is free of voltage!

Product combination

3.1 Functional optimization

Through the combination of reactor and filter components around the converter, abatement of harmonics can be improved.

SIDAC RFI suppression filters

SIDAC RFI suppression filters have the following properties:

- SIDAC RFI suppression filters are installed upstream of the DC drive or three-phase AC drive. They dampen and limit the conducted, high frequency (> 150 kHz to 30 MHz) interference voltages.
- RFI suppression filters avoid mutual interference caused by high-frequency interference currents.
- Under some conditions, use of a sine-wave filter increases the maximum permissible motor cable length, which can be limited by the use of the RFI suppression filter.

Line reactors

To benefit from an additional reduction in phase effects on the system, combine an RFI suppression filter with a SIDAC line reactor/commutating reactor.

Application-specific measurement is required

Ensure compliance with EMC regulations in individual cases by means of an application-specific measurement. This measurement must be requested and ordered separately. The converter's rating data must be taken into account when selecting a filter.

For more detailed advice, please send an e-mail to: MD_Inquiry.aud@siemens.com

Functions

4.1 Method of operation

Output reactor functions

The output reactors function in the following manner:

Output reactors are used on the load side of frequency converters. They compensate capacitive switching currents and limit the voltage rate of rise on the motor terminals if long motor cables are used.

This means that longer motor cables can be used. The converters can be better utilized as the load with harmonic currents is reduced.

Sine-wave filter functions

Sine-wave filters function in the following manner:

Sine-wave filters are used on the load side of frequency converters. Sine-wave filters filter the frequency converter output variables and thus simulate line-like conditions for the motor.

In addition to limiting the voltage rate of rise at the motor terminals in accordance with DIN VDE 0530 or EC 60 034-17, the possibility of longer motor cables is provided. The generation of noise on the motor is significantly reduced. The service life of the motor is extended by the reduced applied voltage to the insulating system.

Application planning

5.1 Configuration

Use the flow chart below to configure the use of sine-wave filters or output reactors

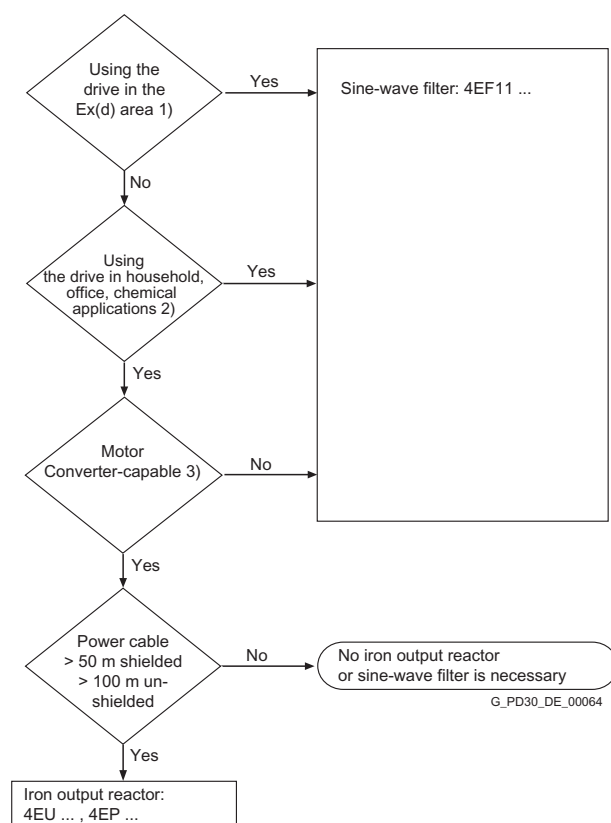

Figure 5-1 Configuration

1) If a sine-wave filter is on the converter downstream of the Ex(d) motor then the rated conditions must be clarified on a case-by-case basis.

2) Household, office: Low-noise motor operation, chemical applications: $dv/dt \leq 500 \text{ V}/\mu\text{s}$, distortion factor $< 10\%$

3) Siemens 1LA motors are converter-capable. If no information is provided about the insulation properties of the motor, a sine-wave filter should be used.

5.2 EMC-compliant configuration of drive systems

The basic rules of EMC

The following 20 rules must be adhered to for the configuration of EMC-compliant drive systems. Rules 1 to 13 apply on a general level. Rules 14 to 20 are particularly important for limiting emitted interference.

General rules

Rule 1

- Ensure that all metal parts of the control cabinet are surface-connected with good conductivity (not paint on paint). If necessary, use contact washers or serrated lock washers.
- When connecting the control cabinet door to the control cabinet, use bonding strips that are as short as possible (also see Rule 20).
- Suitable line/commutating reactors are recommended as a means of counteracting low-frequency phase effects on the system and protecting the converter. You must install these between the line connection and the RFI suppression filter inside a metal cabinet. Ensure that the control cabinet configuration, system configuration and wiring are carried out in compliance with the rules of EMC-compliant configuration.
- On the line side, route the grounding to the motor via the reactor, filter and converter.

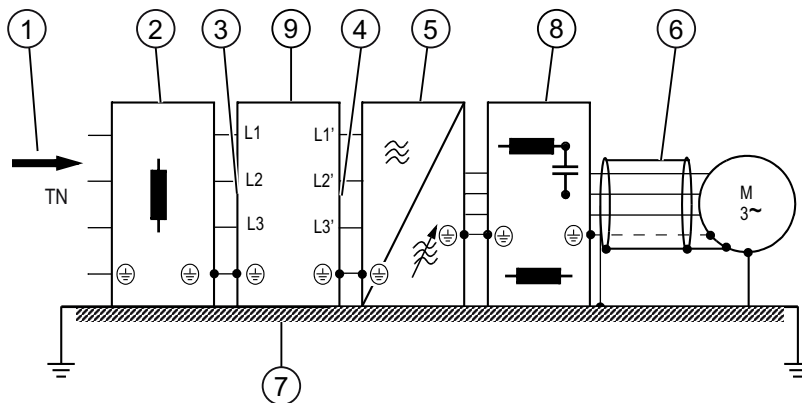

Figure 5-2 Mounting on mounting plate

1	TN system	6	Shielded motor cable
2	Line reactor	7	Metal mounting plate
3	Supply system	8	Sine-wave filter or output reactor
4	Load	9	RFI suppression filter
5	Frequency converter		

Grounding systems/machines and grounding drives

- The grounding of systems/machines is a protective measure.
- In the case of drives, grounding affects emitted interference and interference immunity.
- System grounding can be carried out point-to-point or two-dimensionally.
- For drives, select two-dimensional grounding, i.e., all the parts of the system that need to be grounded are connected two-dimensionally or as a mesh.
 - The motor must be connected using a shielded cable.
 - Unshielded motor cables must only be used in conjunction with a sine-wave filter.
 - The shield must be applied to the surface of the motor and converter.

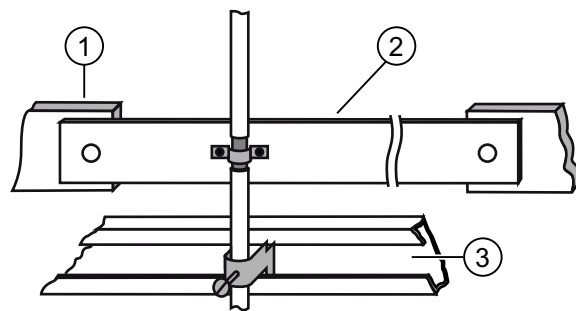

Figure 5-3 Shield connection of motor cables inside control cabinet

- 1 Connect to cabinet enclosure on both sides ensuring good conductivity and maximum contact area
- 2 Shielding bus
- 3 Cable propping bar

Rule 2

- When laying the signal cables and power cables, ensure that sufficient space is left between them (minimum distance: 20 cm).
- Avoid data links
- Provide separating plates between power cables and signal cables.
- Ensure multiple grounding of separating plates.

Rule 3

Connect contactors, relays, solenoid valves, electromechanical operating hours counters, etc., inside control cabinet using interference suppression combination, e. g., RC elements, diodes, varistors. Install the protective circuit directly on the relevant coil.

Rule 4

Twist unshielded cables from the same electric circuit (go and return conductors) or ensure that the surface area between the go and return conductors is as small as possible to avoid unnecessary frame antennae.

Rule 5

Avoid unnecessarily long cables. Thus coupling capacitances and coupling inductances are kept small.

Rule 6

Ground spare cores at both ends. This achieves an additional shielding effect.

Rule 7

Lay cables close to grounded plates to reduce interference coupling. You should not, therefore, route wiring and spare cables randomly within the cabinet; instead, keep them close to the cabinet enclosure/mounting plates.

Rule 8

Use a shielded cable to connect tachometers, encoders and resolvers. Connect the shield to the tachometer, encoder or resolver and to the converter, ensuring maximum contact area. The shield must not be broken at any point, e. g., by intermediate terminals.

Rule 9

- Ground the shields of digital signal cables on both sides (sender and receiver), ensuring maximum contact area and good conductivity.
- In the event of poor equipotential bonding between the shield connections, run an additional equalizing conductor with a cross-section of at least 10 mm² parallel to the shield for the purpose of reducing the shield current.
- Multiple grounding of the shields (= connection to cabinet enclosure) is possible. Multiple grounding of the shields is even possible outside the control cabinet.
- Foil shields are at least 5 times less effective than braided shields.

Rule 10

- Ground the shields of analog signal cables with good equipotential bonding on both sides. Good equipotential bonding is achieved if Rule 1 is followed.
- If low-frequency interference occurs on the analog lines, e. g.: Speed/measured value fluctuations as a result of equalizing currents (hum) then connect the analog signal shield to the signal sink on one side, e. g. analog input of the converter. Ground the other side of the shield via a capacitor (e. g., 10 nF/100 V type MKT). The use of the capacitor means that the shield is connected for high frequencies on both sides.

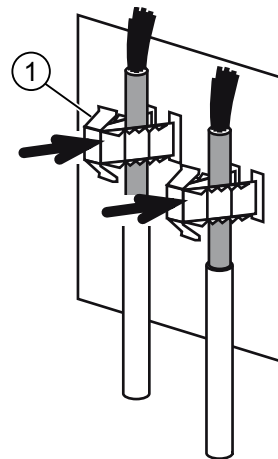

Shield connection of signal cables

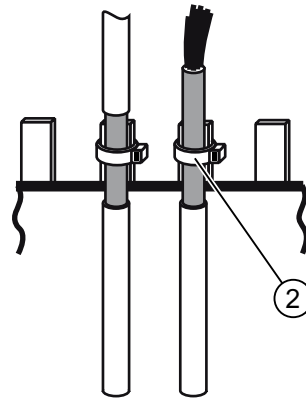

Cable tie

- 1 Shield clip
- 2 Cable tie

Rule 11

Only route signal cables into the cabinet from one side

Rule 12

- If converters are to be operated by means of an external 24 V power supply, this supply must not be connected to a number of loads that have been installed separately inside different control cabinets (hum!).
- Ensure that there is a separate power supply for each converter.

Rule 13

- Avoid interference coupling via the line connection.
- Connect the converter and PLCs/control electronics to different line supplies.
- If only one common line supply is available, isolate the PLCs/control electronics from the line supply by means of an isolating transformer.

Rules for limiting emitted interference

Rule 14

- An RFI suppression filter must be used to ensure compliance with limit class A or B (EN 55011) even in cases where sine-wave filters or dv/dt filters have been installed between the motor and the converter.
- The issue of whether an additional filter is required for further loads depends on the controller used and how the rest of the control cabinet is wired.

Rule 15

- Ensure that the RFI suppression filter is located in the vicinity of the source.
- Ensure that the filter is surface-connected to the control cabinet enclosure, mounting plate, etc. A bare, metallic mounting plate is preferable (e. g. stainless steel, galvanized steel), since the entire contact surface establishes the electrical contact. If a painted mounting plate is used, the screw positions for mounting the frequency converter and RFI suppression filter must be paint-free to ensure electrical contact with the mounting plate.
- Physically separate the input and output cables of the RFI suppression filter.

Rule 16

- Use shielded cables to connect all variable-speed motors in order to limit emitted interference.
- Connect both sides of the shields to the relevant enclosures in a manner that ensures low inductance (short and maximum possible contact area).
- Shield the motor cables inside the control cabinet or shield them by means of grounded separating plates. Suitable motor cables are, for example, Siemens PROTOFLEX-EMV-CY (4 x 1.5 mm² to 4 x 120 mm²) with Cu shield. Cables with steel shields are not suitable.
- Use a suitable screwed joint with shield contact on the motor for the shield connection. Make sure that there is a low-impedance connection between the motor terminal box and motor housing. If necessary, use an additional flexible grounding stranded wire. The motor terminal box must not be made of plastic.

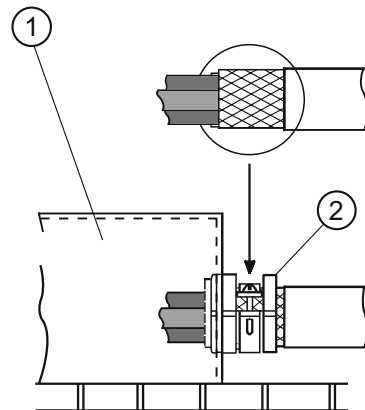

Shield connection on motor

- | | |
|---|-----------------------------------|
| 1 | Motor terminal box |
| 2 | Metric/heavy-gauge threaded joint |

Rule 17

Install a line reactor between the RFI suppression filter and the line supply.

Rule 18

Physically separate the power supply cable and motor cables, e. g., by using grounded separating plates.

Rule 19

The shield between the motor and converter must not be broken at any point as a result of integrating components such as output reactors, sinusoidal filters, dv/dt filters, fuses and contactors. Assemble the components on a mounting plate, which will simultaneously serve as the shield connection for the incoming and outgoing motor cables. It may be necessary to use grounded separating plates for the purpose of shielding the components.

Rule 20

- To limit interference radiation (particularly in the case of limit class B), all cables connected to the control cabinet from the outside must be shielded in addition to the power supply cable.
- When mounting inside a cabinet, install the RFI suppression filter (and if necessary a reactor) in the direct vicinity of the converter.
- When laying cables, keep them as short as possible.
- When connecting the power supply cable to the RFI suppression filter (or reactor), ensure that it is kept separate from other cables so that no interference can be injected into the interference-suppressed power supply cable that would partially cancel out the effects of the RFI suppression filter.
- Connect the housing of the converter and RFI suppression filter with low resistance for high-frequency interference currents. This can be achieved by placing the converter and RFI suppression filter on the same mounting plate. Ensure that the converter and RFI suppression filter are surface-connected to this mounting plate. The best solution here is

to use a bare metal mounting plate (e. g., made of stainless steel or galvanized sheet-steel), since the total contact surface establishes the electrical contact. If a painted mounting plate is used, the screw positions for the converter and RFI suppression filter must be paint-free to ensure electrical contact with the mounting plate.

Installation

6.1 Assembly

Installation

Install the sine-wave filter or the output reactor on a bare metal plate.

Mount the sine-wave filter or the output reactor in a cabinet as follows:

- Install the sine-wave filter or the output reactor as close to the converter as possible.
- When laying cables, keep them as short as possible.
- Lay out the motor cables separate from the other cables, such as power supply cable so that interference cannot be coupled.
- The output reactor / sine-wave filter are each fastened with 4 screws via the fastening bores provided in the base plate. The bore dimensions and the strength class of the screws used are specified in the following dimension drawings.

Mounting position

The mounting position of the sine-wave filter or the output reactor must be selected in such a manner that the cooling channels - if present - are arranged vertically.

In addition, ensure that the cooling air flow (natural convection) is not impacted by neighboring components, connecting lines, etc. The capacitors of the sine-wave filter should not be impacted by the waste heat of the reactor.

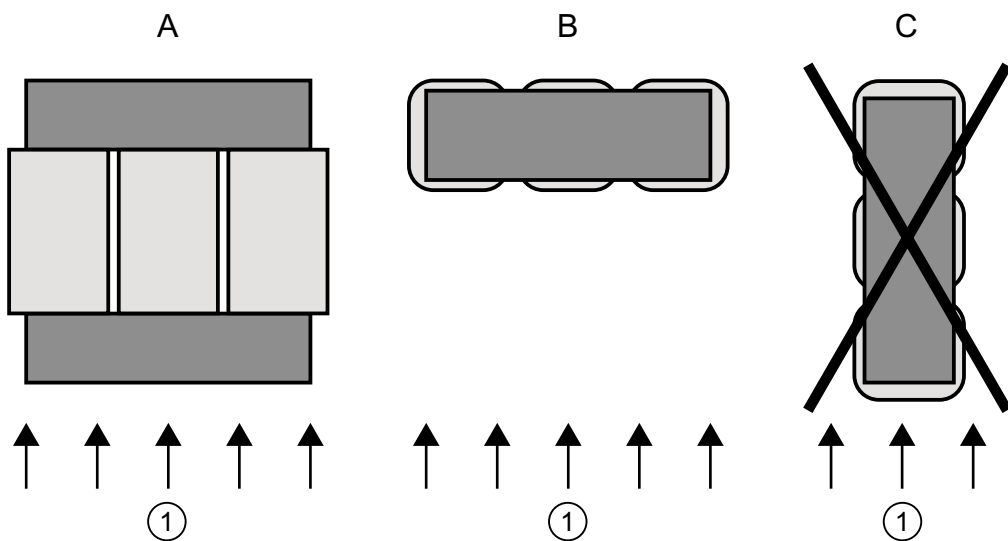
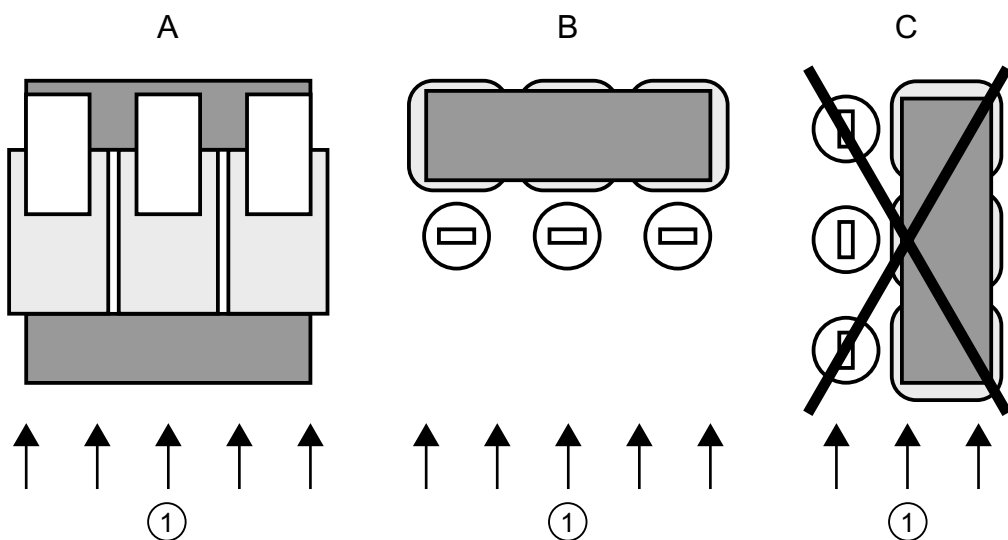

Figure 6-1 Mounting position - output reactors

(1) Cooling air flow

Permissible mounting positions - output reactors

	A	B	C
4EP	✓	✓	—
4EU	✓	—	—



(1) Cooling air flow

Permissible mounting positions sine-wave filter

	A	B	C
4EF1105-0GB... 4EF1105-3GB	✓	✓	—
4EF1105-4GB... 4EF1105-8GB 4EF1105-0GB	✓	—	—

Dimension sheet / bore dimensions 4EP

Rated AC $I_{LN} \leq 40$ A

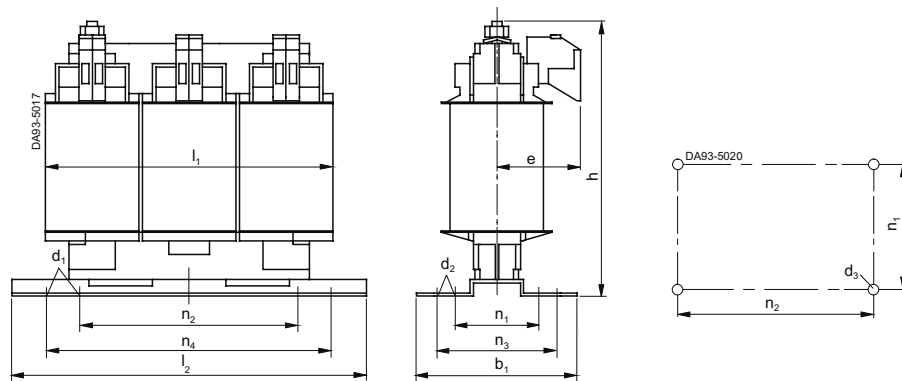

Type	b_1	d_1	d_2	d_3	e	h	l_1	l_2	n_1	n_2	n_3	n_4
4EP36	78	4,8	9	M4	62,0	139	120	148	49	90	58	136
4EP37	73	5,8	11	M5	60,0	159	150	178	49	113	53	166
4EP38	88	5,8	11	M5	67,0	159	150	178	64	113	68	166
4EP39	99	7,0	13	M6	62,0	181	182	219	56	136	69	201
4EP40	119	7,0	13	M6	72,0	181	182	219	76	136	89	201

Dimension sheet / bore dimensions 4EU24 to 4EU36

(For 4EU24 to 4EU36 with flat connections, for arrangement of the reactors on horizontal surfaces)

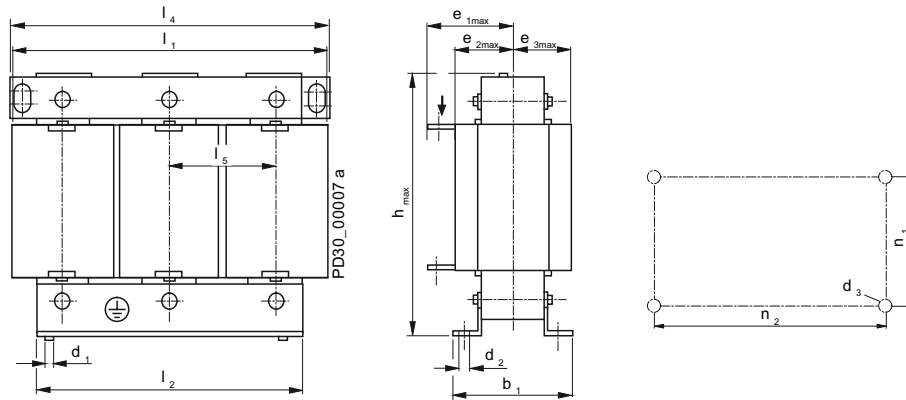

Type	b ₁	d ₁	d ₂	d ₃	e _{1max}	e _{2max}	e _{3max}	h _{max}	l ₁	l ₂	L ₄	L ₅	n ₁	n ₂	Grounding
4EU24	91	7	12	M6	90,5	56,5	48,5	210	225	190	-	76	70	176	M6
4EU25	115	7	12	M6	102,5	68,5	60,5	210	225	190	-	76	94	176	M6
4EU27	133	10	18	M8	120,5	79,5	67,5	248	260	220	270	88	101	200	M6
4EU30 (Cu)	148	10	18	M8	137,0	89,0	73,0	269	295	250	300	100	118	224	M6
4EU30	148	10	18	M8	144,0	98,0	86,0	269	295	250	300	100	118	224	M6
4EU36 (Cu)	169	10	18	M8	142,0	94,0	78,0	321	357	300	350	120	138	264	M8
4EU36	169	10	18	M8	161,0	111,0	91,0	321	357	300	350	120	138	264	M8

Dimension sheet / bore dimensions 4 EF11

(for drives in the range from 7.5 kW to 1.5 kW)

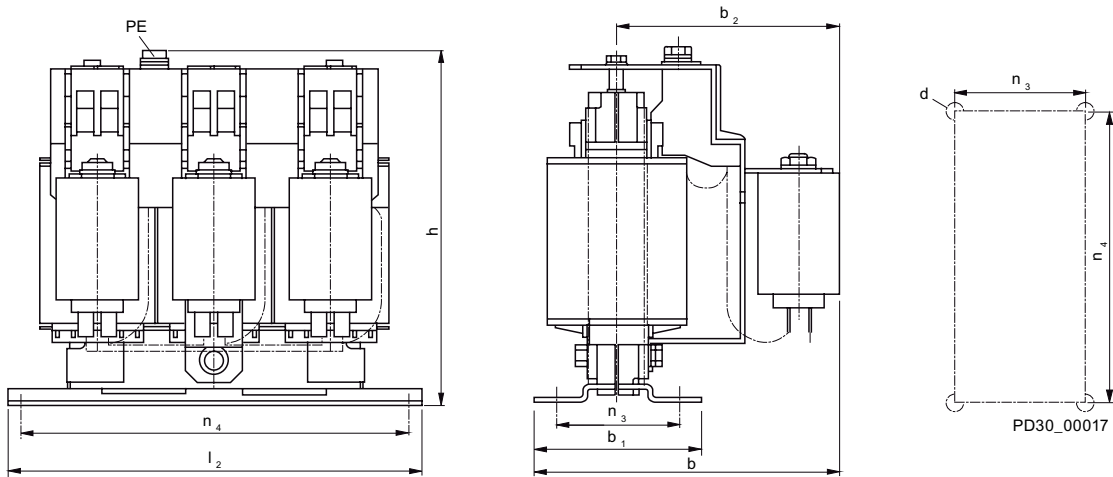

For filters with I_{max} to	b_{max}	b_1	b_{2max}	d	h_{max}	l_2	n_3	n_4	Grounding
6 A	133	73	98	M5	157	178	53	166	M6
10 A	148	88	105	M5	157	178	68	166	M6
17.5 A	175	119	112	M6	182	219	89	201	M6

Dimension sheet / bore dimensions 4 EF11

(For drives in the range of 11 kW to 75 kW, for arrangement of the filter on horizontal surfaces)

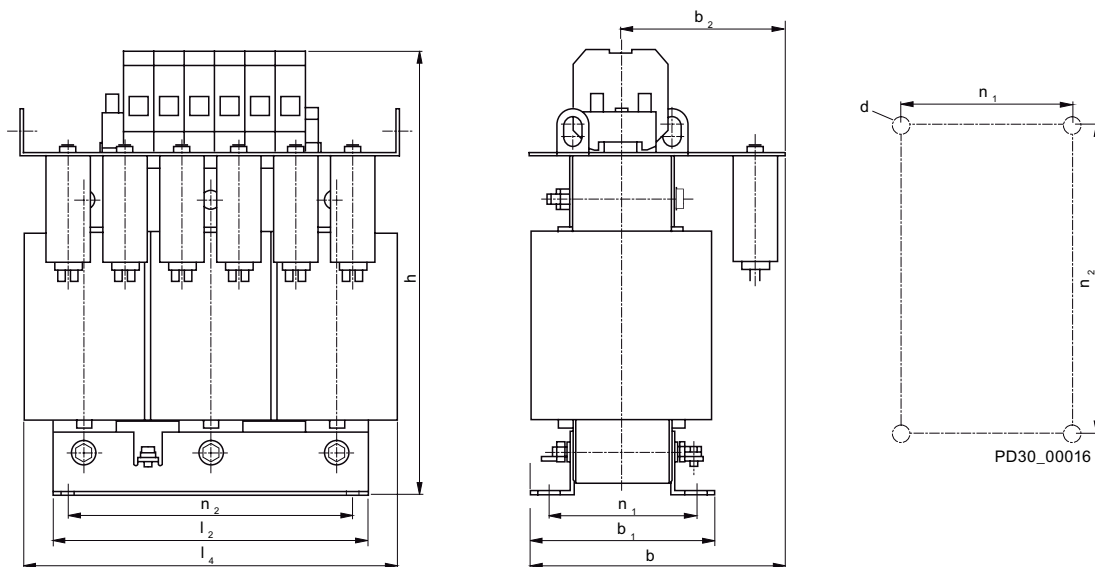

For filters with I_{max} to	b_{max}	b_1	b_2	d	h_{max}	l_2	L_{4max}	n_1	n_2	Grounding
26 A	145	91	100	M6	253	189	225	70	176	M6
38 A	169	115	112	M6	253	189	225	94	176	M6
48 A	168	118	112	M8	300	220	260	86	200	M6
63 A	183	133	120	M8	300	220	260	101	200	M6
90 A	208	148	134	M8	362	249	295	118	224	M6
105 A	224	168	136	M8	418	299	357	138	264	M8

6.2 Installation instructions

EMC-compliant configuration

- To ensure trouble-free operation of the sine-wave filter / output reactor, the configuration of the drive system must be EMC-compliant. The basic rules for the EMC-compliant configuration of drive systems are outlined in section 5.
- Install the converter and the sine-wave filter / output reactor on a common bare metal mounting plate (stainless steel or galvanized sheet-steel). The total contact surface establishes the electrical contact.
- If a painted mounting plate is used, ensure that the screw positions for the converter and sine-wave filter / output reactor are paint-free to ensure electrical contact with the mounting plate.
- If the motor is connected via a shielded cable, place the shield on the motor and on the sine-wave filter / output reactor so that it is surface connected.

Connection

7.1 Prerequisites and definitions

Materials to be used

The following materials must be used for the connection:

- Busbar material: Copper, aluminum
- Bolt: Strength class 8.8 or higher in accordance with ISO 898 Part 1, tZn (hot-galvanized) anti-corrosion protection
- Nut: Strength class 8 or higher in accordance with ISO 898 Part 2, tZn (hot-galvanized) anti-corrosion protection
- Spring element on bolt and nut side:
 - Clamping washer to DIN 6796 Part 2, with anti-corrosion protection
 - Spring lock washer to DIN 128
- Lubricant: MoS₂-based

7.2 Connection options

Protective conductor connection via terminal studs

The following tightening torque applies for protective conductor connections on the sine-wave filter / output reactor that are contacted via threaded pins: 6 Nm

The following graphics show the protective conductor connection via terminal studs.

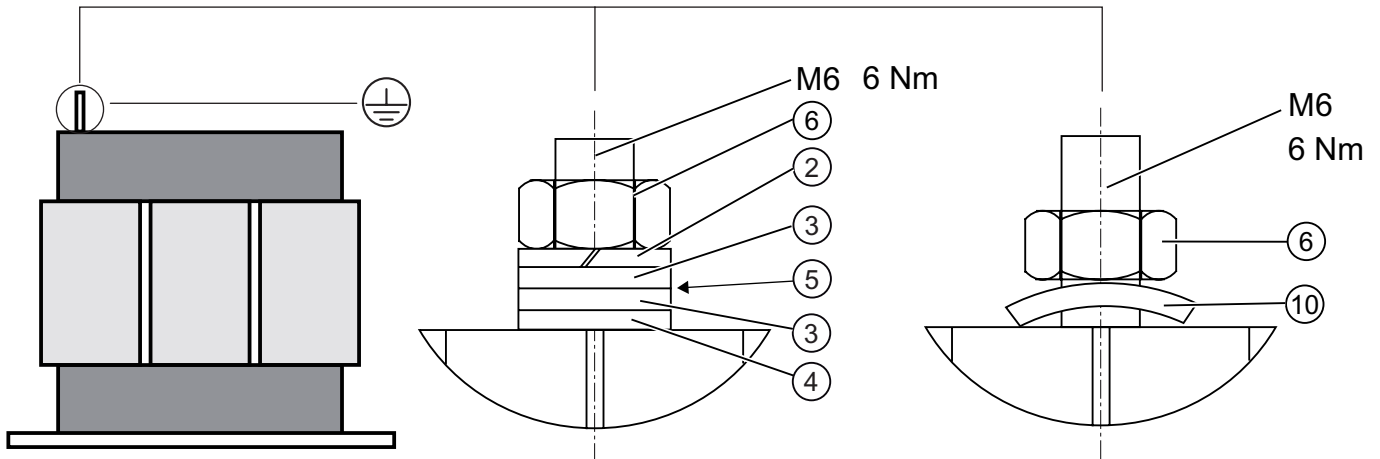

Figure 7-1 Protective conductor connection via terminal studs (output reactor)

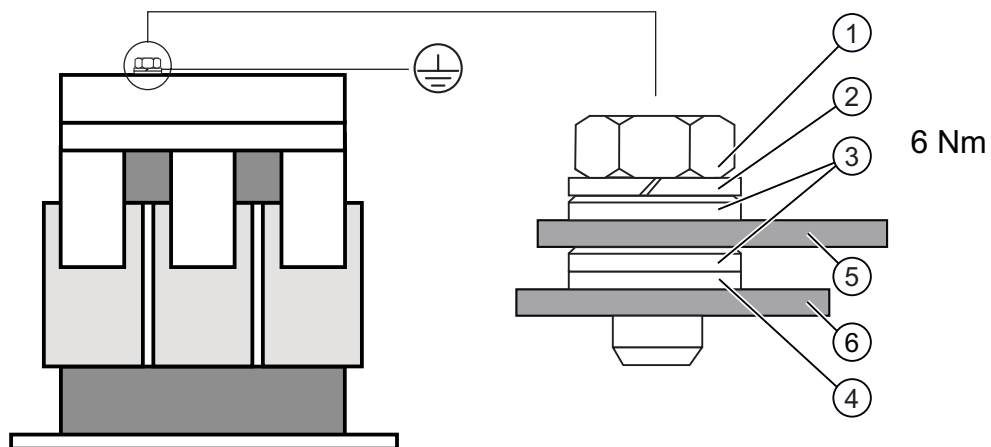

Figure 7-2 Protective conductor connection via terminal studs (sine-wave filter)

- (1) Bolt
- (2) Spring washer
- (3) Conical spring washer
- (4) Contact washer
- (5) Cable lug: The cable lug of the protective conductor must be arranged between the two washers.
- (6) Nut (output reactor) / capacitor holding plate (sine-wave filter)
- (7) Protective conductor clip
- (10) Caliper (output reactor)

Protective conductor connection via clip on the angle bracket

The following tightening torque applies for protective conductor connections on the sine-wave filter / output reactor that are contacted via clip on the angle bracket: 10 Nm

The following graphics show the protective conductor connection via clip on the angle bracket.

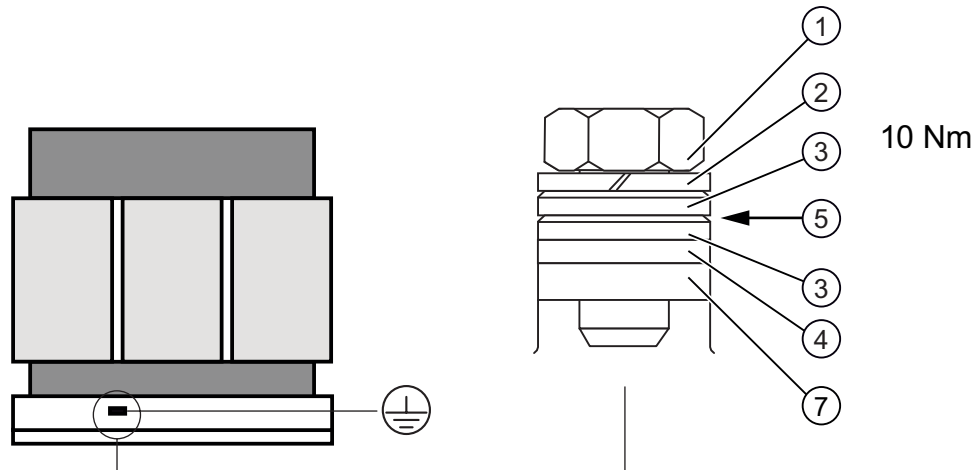

Figure 7-3 Protective conductor connection via clip on the angle bracket (output reactor)

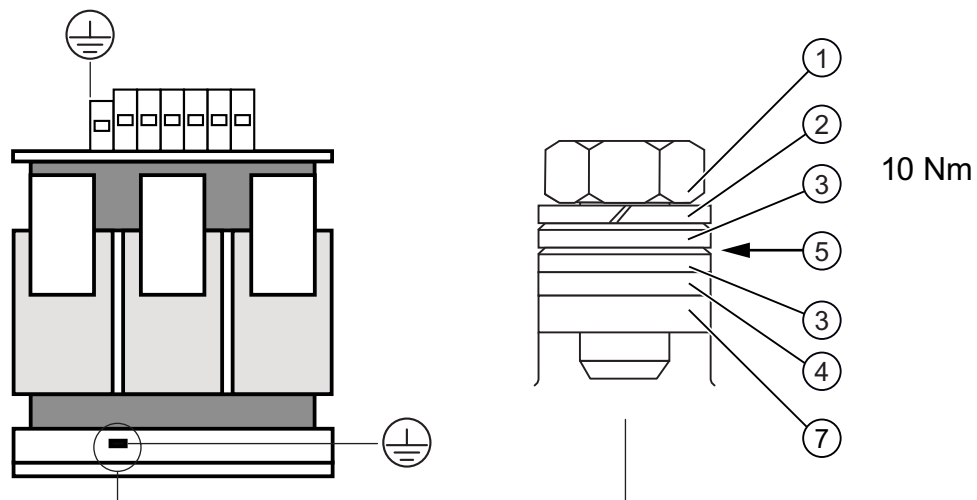

Figure 7-4 Protective conductor connection via clip on the angle bracket (sine-wave filter)

- (1) Bolt
- (2) Spring washer
- (3) Conical spring washer
- (4) Contact washer
- (5) Cable lug: The cable lug of the protective conductor must be arranged between the two washers.
- (6) Nut (output reactor) / capacitor holding plate (sine-wave filter)
- (7) Protective conductor clip

Connection via terminals

The cables should be stripped until the stripped part of the cable can be completely introduced into the contact part of the terminals without canting.

The insulation of the cable should be placed on the contact part of the terminal in such a manner that the conductor is not crushed when unscrewed.

The information provided in the tables below applies for connection of the sine-wave filter / output reactor via terminals:

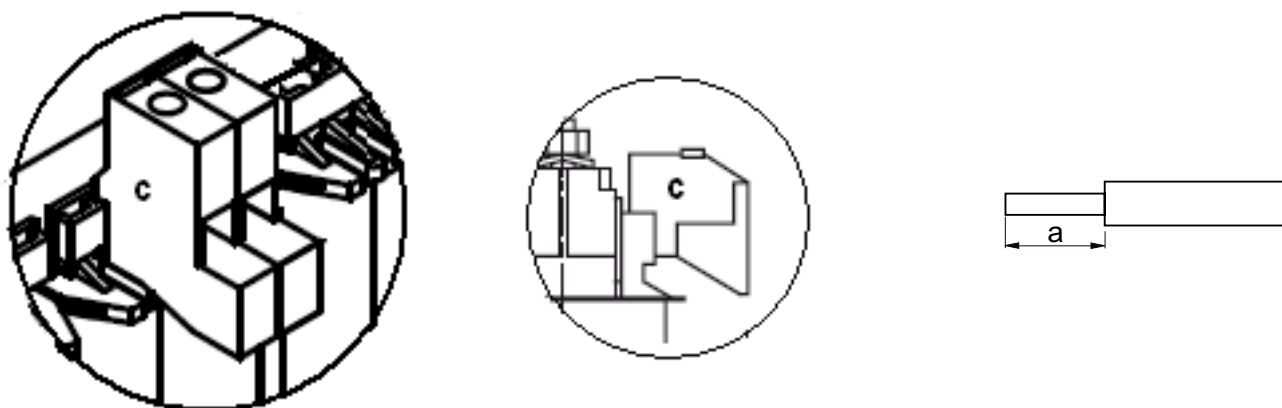

Figure 7-5 Connection - terminal output reactor

Connecting terminal	Stripped length (a)	Tightening torque
Type	mm	Nm
(c) Double terminal	13...14	2,5

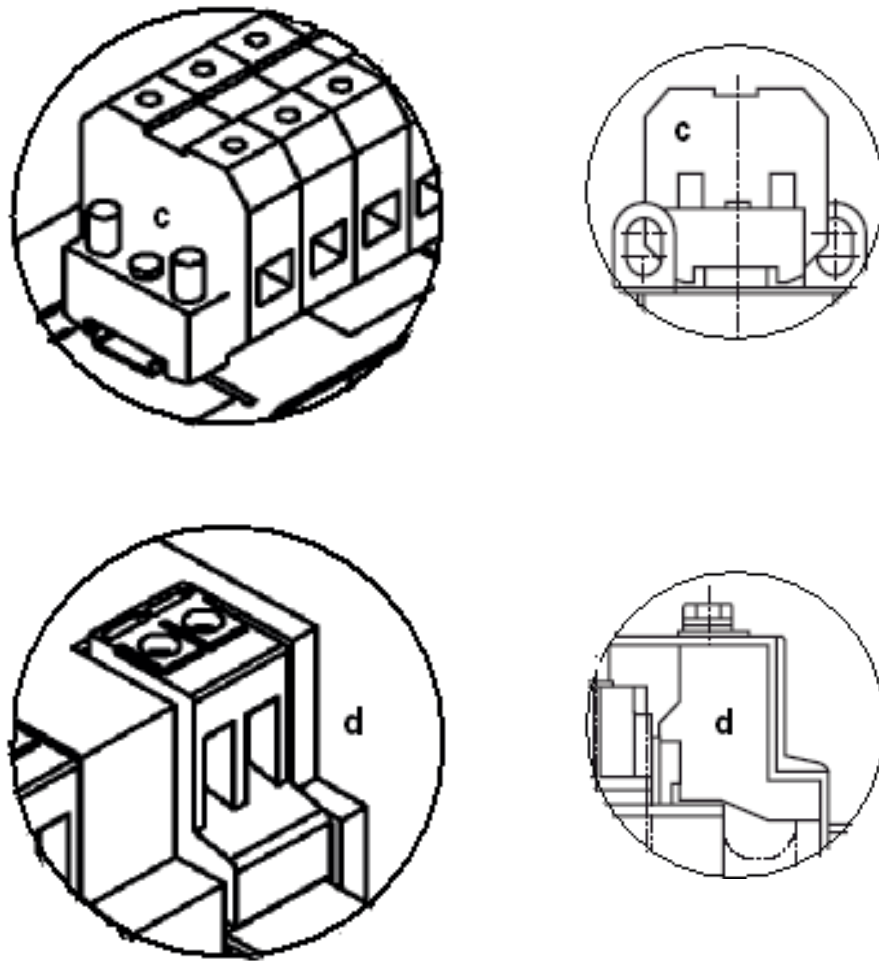

Figure 7-6 Connection terminal - sine-wave filter

Connection grounding	Conductor cross-section	Tightening torque
Type	mm ²	Nm
(c)	16	0,9 ... 1,3
(c)	35	2,5 ... 3,0

Connection	Conductor cross-section	Tightening torque
Type	mm ²	Nm
(d)	16	2,0 ... 2,5
(c)	16	0,9 ... 1,3
(c)	35	2,5 ... 3,0
(c)	70	6,0 ... 10,0

Flat connectors

The customer-provided connection is executed as shown in the illustration, via cable lugs or external busbars using the parts listed in the table. The level contact surfaces of the flat connections must be bare metal with a light coating of grease. Do not align the cable shoes after tightening the screw connection (danger of loosening).

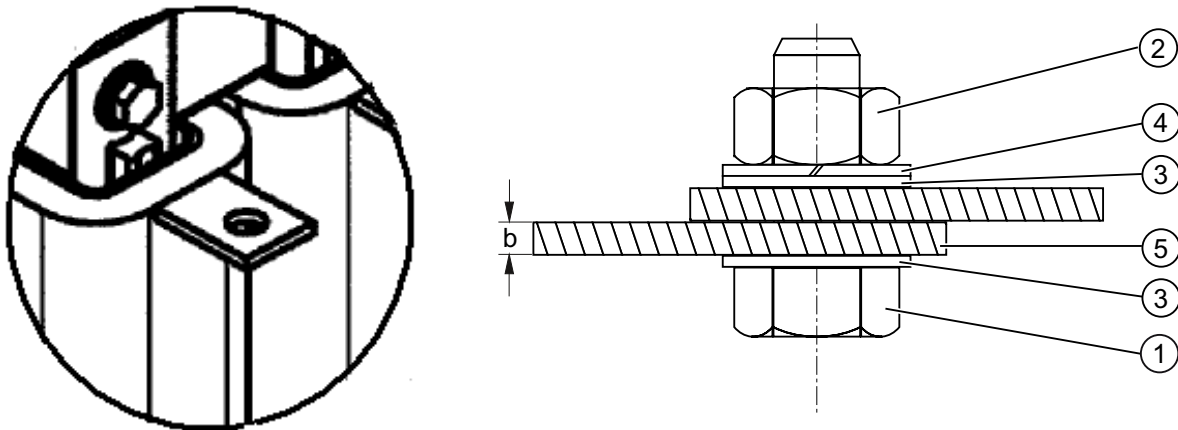

Figure 7-7 Flat connection

Item no.	Description	Rated current I_{thmax} [A]	
		< 80	< 200
(1)	Bolt	M8	M10
(2)	Nut	M8	M10
(3)	Washer	8.4 x 16	10.5 x 20
(4)	Spring washer	8.2 x 14.4	10.5 x 17.4
(5)	Flat connection	b = 3.0 mm	b = 5.0 mm
	Tightening torque [Nm]	13,0	25,0

Commissioning

8.1 Operation

Operation

The following must be observed when operating the sine-wave filter / output reactor:

 CAUTION
--

The following general parameters always apply for operation and they should not be exceeded:
--

Motor cable length - maximum 200 m, shielded cable

Motor cable length - maximum 300 m, unshielded line

Maximum motor cable length cross-sections for power classes:

- > to 2.2 kW 1.5 mm²

- > 2.2 kW to 7.5 kW 2.5 mm²

- > 7.5 kW to 11 kW 4 mm²

- > 11 kW to 22 kW 10 mm²

- > 22 kW to 30 kW 16 mm²

- > 30 kW to 37 kW 25 mm²

- > 37 kW to 50 kW 35 mm²

- > 50 kW to 75 kW 70 mm²

Maximum clock frequency 8 kHz

Maximum motor frequency - output reactor 200 Hz

Maximum motor frequency sine-wave filter 100 Hz

UN 3 AC 500 V + 5 % (+ 10 % sine wave filter)

For more extensive requirements customer-specific solutions are available on request:

email: MD_Inquiry.aud@siemens.com

Use in Ex(d) area

If a sine-wave filter is on the converter upstream of the Ex(d) motor then the implementation conditions must be clarified for each request.

- Compliance with the rated data on the rating plate is prerequisite for proper use of the sine-wave filter / output reactor.

CAUTION
 The inputs and outputs of the sine-wave filter should not be swapped because this can damage the frequency converter.

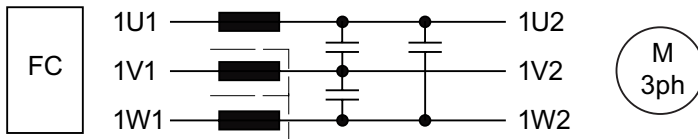

Figure 8-1 Connection - sine-wave filter

CAUTION
 Do not operate the sine-wave filter without load because the converter and filter could be damaged.

- If you notice any deviations from normal operation (increased power consumption, temperature or levels of vibration, unusual noises or odors, monitoring devices tripping, etc.), the device is probably no longer functioning correctly.

In such an event, you must notify the responsible service personnel immediately to prevent faults that could result in personal injury or material damage.

- If in doubt, shut down the equipment concerned immediately.

Maintenance and servicing

9.1 Service/Maintenance

You must comply with the following safety regulations before commencing work on electrical installations:

1. Isolate from the supply
2. Secure against accidental restart
3. Check safe isolation from supply
4. Grounding and short-circuiting
5. Cover all nearby live parts

Checking safe isolation from supply

 WARNING
Dangerous high voltage Danger of death or serious injury. Before commencing work on the sine-wave filter / output reactor, you must check that it is safely isolated from the supply (e. g. using a meter).

Service

The following service operations should be carried out regularly (preferably on an annual basis):

- General visual check
- Remove excessively large dust deposits using compressed air (max. 2.5 bar) and a suitable vacuum cleaner.
- Tighten up connection elements in accordance with the specified torques.

Technical specifications

10.1 Rating data

Technical specifications - output reactor

Recommended supply voltage V_N Rated AC I_{LN} Inductance per strand L_N Total power loss P_v Total weight m	See rating plate or catalog LV60 Reactors and Filters, table "Selection and ordering data"
Frequency	Converter output frequency maximum 200 Hz Clock frequency of the converter to 8 kHz
Degree of protection	IP00 in accordance with DIN VDE 0470-1/EN 60529
Connection	4EP terminal, 4EU flat connection, see "Engineering information", terminal cover for protection against unintentional contact of the flat connections, see "Accessories"
Measurement of creepage distances and clearances	Degree of pollution 2 in accordance with DIN VDE 0110
Rated voltage for insulation (for installation altitudes to 2000 m above sea level)	Version with terminals: 690 V AC Version with flat connectors: 1000 V AC
Permissible ambient temperature during operation	0 °C to +40 °C
Temperature classes	Type 4EP ta 40 °C/F Type 4EU ta 40 °C/H
Installation altitude	≤ 1000 m above sea level
Standards / approvals	The reactors satisfy EN 61558-2-20 UL508: for types 4EP UL1561: For types 4EU
Storage temperature	-25 °C to +55 °C
Transport temperature range	-25 °C to +70 °C
Permissible humidity rating	Moisture 5 % to 95 %, occasional condensation is permissible

Technical specifications - sine-wave filter

Recommended supply voltage V_N Rated AC I_{LN} Total power loss P_v Total weight m	See rating plate or catalog LV60 Reactors and Filters, table "Selection and ordering data"
Test voltage	3.6 kV DC active parts against housing
Power range of the drive	1.5 kW to 75 kW, greater power ranges on request
Frequency	$f_{max} = 100$ Hz Clock frequency ≥ 4 kHz ≤ 8 kHz
Degree of protection	IP00 in accordance with DIN VDE 0470-1/EN 60529
Connection	Safe-to-touch terminals
Measurement of creepage distances and clearances	Degree of pollution 2 in accordance with DIN VDE 0110
Rated voltage for insulation (for installation altitudes to 1000 m above sea level)	500 V AC
Permissible ambient temperature during operation	0 °C to +40 °C
Temperature classes	ta 40 °C/F or ta 40 °C/H depending on the rated power
Installation altitude	≤ 1000 m above sea level
Standards / approvals	The reactors satisfy EN 61558-2-20 UL508: Device assembly
Storage temperature	-25 °C to +55 °C
Transport temperature range	-25 °C to +70 °C
Permissible humidity rating	Moisture 5 % to 95 %, occasional condensation is permissible

10.2 Deviation in the rated values at installation altitudes > 1000 m

The following diagrams show the reduction in rated voltage, the rated current, depending on the installation altitude and coolant temperature

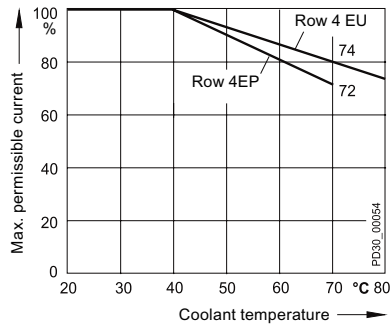

Deviation in the permissible direct current of the rated equalizing current I_{dn} , or permissible alternating current of the rated AC I_n (at coolant temperatures $\neq 40^\circ\text{C}$)

Characteristic curve 74 applies for reactors 4EU, 4ET, 4PK

Characteristic curve 72 applies for reactors 4EP, 4EM, 4EF11

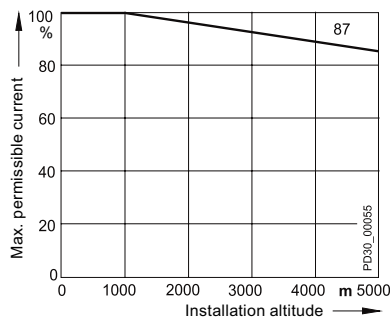

Deviation in the permissible direct current of rated equalizing current I_{dn} , or permissible alternating current of the rated AC I_n (at installation altitudes > 1000 m above sea level)

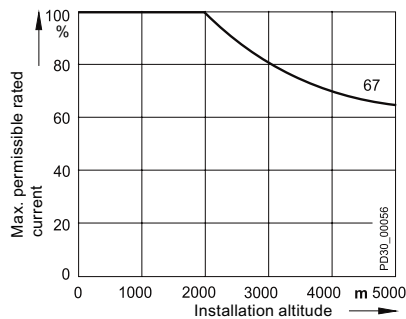

Reduction of the rated voltage for insulation (at installation altitudes > 2000 m above sea level)

Circuit diagrams

11.1 Circuit diagrams

Sine-wave filter circuit diagram

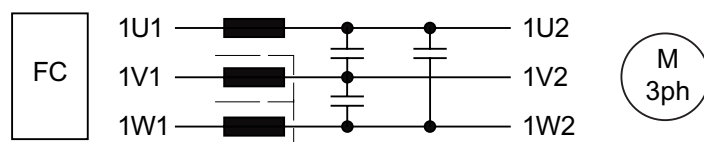

Output reactor circuit diagram

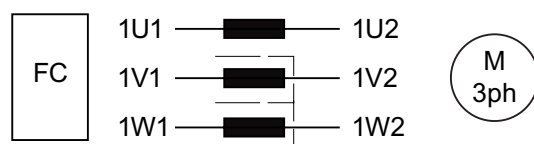

A

List of abbreviations

A.1 List of abbreviations

AC

Alternating Current

DC

Direct Current

Ex(d) area

Necessary flameproof enclosure against potentially explosive atmospheres

LF harmonics

Low frequency harmonics

TN system

A point in the system (star point, external conductor) is directly grounded. The conductive parts of the electrical equipment are connected to the grounded system point via protective conductors.

Index

C

Commutating reactor, 7, 8, 11, 16
Cooling air flow, 23

E

EMC regulations, 9, 11, 16, 28

G

Grounding, 16

I

Interference coupling, 16, 18, 19, 23

L

Line reactor, 7, 8, 11, 16, 20

M

Motor cable length, 11, 13, 35
Mounting position, 20, 23, 25

O

Output reactor, 5, 7, 8, 9, 13, 15, 16, 21, 23, 28, 30, 31, 32, 35, 37
 Circuit diagram, 43
 Technical specifications, 39

P

Protective conductor, 29, 30, 45

R

RFI suppression filter, 7, 8, 11, 16, 19, 20, 21

S

Safety rules, 37
Shield, 9, 17, 18, 20, 21, 28, 35
Sine-wave filter, 5, 7, 8, 9, 13, 15, 16, 19, 21, 23, 25, 28, 30, 31, 33, 35, 37
 Circuit diagram, 43
 Technical specifications, 40
Smoothing reactor, 7, 8
Standards, 5, 13, 19, 29