

The documentation and process conversion measures necessary to comply with this revision shall be completed by 28 November 2000.

INCH-POUND

MIL-PRF-19500/349E  
 28 August 2000  
 SUPERSEDING  
 MIL-PRF-19500/349D  
 12 December 1997

PERFORMANCE SPECIFICATION

SEMICONDUCTOR DEVICE, TRANSISTOR, NPN, SILICON, SWITCHING  
 TYPES 2N3506, 2N3506A, 2N3506L, 2N3506AL, 2N3507, 2N3507L, 2N3507A, 2N3507AL,  
 JAN, JANTX, JANTXV, AND JANS

This specification is approved for use by all Departments and Agencies of the Department of Defense.

1. SCOPE

1.1 Scope. This specification covers the performance requirements for NPN, silicon, switching transistors. Four levels of product assurance are provided for each device type as specified in MIL-PRF-19500.

1.2 Physical dimensions. See figure 1 (similar to T0-39).

1.3 Maximum ratings. (1)

P <sub>T</sub> (2) T <sub>A</sub> = +25°C	P <sub>T</sub> (3) T <sub>C</sub> = +25°C	V <sub>CBO</sub>		V <sub>CEO</sub>		V <sub>EBO</sub>	I <sub>C</sub>	T <sub>J</sub> and T <sub>STG</sub>	R <sub>θJA</sub>
		2N3506 2N3506A	2N3507 2N3507A	2N3506 2N3506A	2N3507 2N3507A				
<u>W</u>	<u>W</u>	<u>V dc</u>	<u>V dc</u>	<u>V dc</u>	<u>V dc</u>	<u>V dc</u>	<u>A dc</u>	<u>°C</u> -65 to +200	<u>°C/W</u> 175
1.0	5.0	60	80	40	50	5.0	3.0		

- (1) Electrical characteristics for "A", "AL", and "L" suffix devices are identical to non "L" suffix devices unless otherwise noted.
- (2) Derate linearly 5.71 mW/°C above T<sub>A</sub> = +25°C.
- (3) Derate linearly 28.6 mW/°C above T<sub>C</sub> = +25°C.

1.4 Primary electrical characteristics. (1)

Limits	h <sub>FE2</sub> (2)		h <sub>FE4</sub> (2)		V <sub>CE(sat)</sub>	h <sub>re</sub>	C <sub>obo</sub>	t <sub>on</sub>	t <sub>off</sub>
	2N3506 2N3506A	2N3507 2N3507A	2N3506 2N3506A	2N3507 2N3507A	I <sub>C</sub> = 1.5 A dc I <sub>B</sub> = 150 mA dc	f = 20 Mhz V <sub>CE</sub> = 5 V dc I <sub>C</sub> = 100 mA dc	V <sub>CB</sub> = 10 V dc I <sub>E</sub> = 0 100 kHz ≤ f ≤ 1 MHz	I <sub>C</sub> = 1.5 A dc I <sub>B</sub> = 150 mA dc	
Min	40	30	25	20	<u>V dc</u>	3	<u>pF</u>	<u>ns</u>	<u>ns</u>
Max	200	150			1.0	15	40	45	90

- (1) Electrical characteristics for "A", "AL", and "L" suffix devices are identical to non "L" suffix devices unless otherwise noted.
- (2) Pulsed (see 4.5.1).

Beneficial comments (recommendations, additions, deletions) and any pertinent data which may be of use in improving this document should be addressed to: (Defense Supply Center, Columbus, ATTN: DSCC/VAC, Post Office Box 3990, Columbus, OH 43216-5000), by using the Standardization Document Improvement Proposal (DD Form 1426) appearing at the end of this document or by letter.

AMSC N/A

FSC5961

DISTRIBUTION STATEMENT A. Approved for public release; distribution is unlimited.

Dimensions					
Symbol	Inches		Millimeters		Notes
CD	0.305	0.335	7.75	8.51	
CH	0.240	0.260	6.10	6.60	
HD	0.335	0.370	8.51	9.40	
LC	.200 TP		5.08 TP		6
LD	0.016	0.021	0.41	0.53	7, 8
LL	See notes				7, 8, 11,12
LU	0.016	0.019	0.41	0.48	7, 8
L1		0.050		1.27	7, 8
L2	0.250		6.35		7, 8
P	0.100		2.54		5
Q		0.050		1.27	4
r		0.010		0.25	10
TL	0.029	0.045	0.74	1.14	3
TW	0.028	0.034	0.71	0.86	2
$\alpha$	45/ TP		45/ TP		6

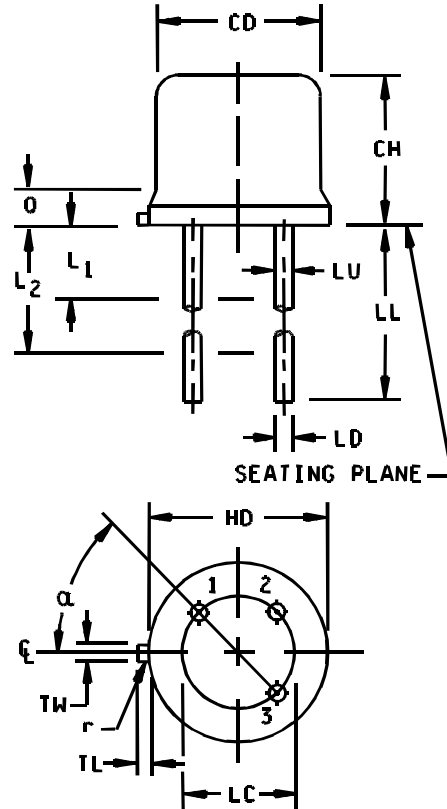

NOTES:

1. Dimension are in inches.
2. Metric equivalents are given for general information only.
3. Beyond r (radius) maximum, TH shall be held for a minimum length of .011 (0.28 mm).
4. Dimension TL measured from maximum HD.
5. Body contour optional within zone defined by HD, CD, and Q.
6. Leads at gauge plane .054 +.001 -.000 inch (1.37 +0.03 -0.00 mm) below seating plane shall be within .007 inch (0.18 mm) radius of true position (TP) at maximum material condition (MMC) relative to tab at MMC.
7. Dimension LU applies between L<sub>1</sub> and L<sub>2</sub>. Dimension LD applies between L<sub>2</sub> and LL minimum. Diameter is uncontrolled in L<sub>1</sub> and beyond LL minimum.
8. All three leads.
9. The collector shall be internally connected to the case.
10. Dimension r (radius) applies to both inside corners of tab.
11. For 2N3506L, 2N3507L, 2N3506AL, and 2N3507AL, dimension LL shall be 1.5 inches (38.1) mm minimum and 1.75 inches (44.4 mm) maximum.
12. For 2N3506, 2N3506A, 2N3507, and 2N3507A dimension LL shall be 0.5 inches (12.7) mm minimum and 0.75 inches (19.0 mm) maximum.
13. In accordance with ANSI Y14.5M, diameters are equivalent to  $\phi$ x symbology.
14. Lead 1 = emitter, lead 2 = base, lead 3 = collector.

FIGURE 1. Physical dimensions (similar to TO-39).

## 2. APPLICABLE DOCUMENTS

### 2.1 Government documents.

2.1.1 Specifications, standards and handbooks. The following specifications, standards, and handbooks form a part of this document to the extent specified herein. Unless otherwise specified, the issues of these documents are those listed in the issue of the Department of Defense Index of Specifications and Standards (DODISS) and supplement thereto, cited in the solicitation (see 6.2).

#### SPECIFICATION

##### DEPARTMENT OF DEFENSE

MIL-PRF-19500 - Semiconductor Devices, General Specification for.

#### STANDARD

##### DEPARTMENT OF DEFENSE

MIL-STD-750 - Test Methods for Semiconductor Devices.

(Unless otherwise indicated, copies of the above specifications, standards, and handbooks are available from the Defense Automated Printing Service, Building 4D (DPM-DODSSP), 700 Robbins Avenue, Philadelphia, PA 19111-5094.)

2.2 Order of precedence. In the event of a conflict between the text of this specification and the references cited herein the text of this specification shall take precedence. Nothing in this specification, however, shall supersede applicable laws and regulations unless a specific exemption has been obtained.

## 3. REQUIREMENTS

3.1 General. The requirements for acquiring the product described herein shall consist of this document and MIL-PRF-19500.

3.2 Qualification. Devices furnished under this specification shall be products that are authorized by the qualifying activity for listing on the applicable qualified products list before contract award (see 4.2 and 6.2 ).

3.3 Abbreviations, symbols, and definitions. Abbreviations, symbols, and definitions used herein shall be as specified in MIL-PRF-19500.

3.4 Interface requirements and physical dimensions. The Interface requirements and physical dimensions shall be as specified in MIL-PRF-19500, and figure 1 (similar to T0-39).

3.4.1 Lead finish. Lead finish shall be solderable in accordance with MIL-PRF-19500.

3.5 Marking. Marking shall be in accordance with MIL-PRF-19500.

3.6 Electrical performance characteristics. Unless otherwise specified herein, the electrical performance characteristics are as specified in 1.3.

3.7 Electrical test requirements. The electrical test requirements shall be group A as specified herein.

3.8 Workmanship. Semiconductor devices shall be processed in such a manner as to be uniform in quality and shall be free from other defects that will affect life, serviceability, or appearance.

4. VERIFICATION

4.1 Classification of Inspections. The inspection requirements specified herein are classified as follows:

- a. Qualification inspection (see 4.2).
- b. Screening (see 4.3)
- c. Conformance inspection (see 4.4).

4.2 Qualification inspection. Qualification inspection shall be in accordance with MIL-PRF-19500.

4.3 Screening. Screening shall be in accordance with table IV of MIL-PRF-19500, and as specified herein. The following measurements shall be made in accordance with table I herein. Devices that exceed the limits of table I herein shall not be acceptable.

Screen (see table IV of MIL-PRF-19500)	Measurement	
	JANS level	JANTX and JANTXV levels
3c	Thermal impedance (see 4.3.2)	Thermal impedance (see 4.3.2)
7	hermetic seal (optional)	(1)
9	$I_{CEX1}$ , $h_{FE2}$	Not applicable
10	48 hours minimum	48 hours minimum
11	$I_{CEX1}$ ; $h_{FE2}$ ; $\Delta I_{CEX1}$ = 100 percent of initial value or 200 nA dc, whichever is greater; $\Delta h_{FE2}$ = 15 percent of initial value	$I_{CEX1}$ and $h_{FE2}$
12	See 4.3.1 240 hours minimum	See 4.3.1 80 hours minimum
13	Subgroups 2 and 3 of table I herein; $\Delta I_{CEX1}$ = 100 percent of initial value or 200 nA dc, whichever is greater; $\Delta h_{FE2}$ = 15 percent of initial value.	Subgroup 2 of table I herein; $\Delta I_{CEX1}$ = 100 percent of initial value or 200 nA dc, whichever is greater; $\Delta h_{FE2}$ = 15 percent of initial value.

(1) Hermetic seal test shall be performed in either screen 7 or screen 14.

4.3.1 Power burn-in conditions. Power burn-in conditions are as follows:  $T_A$  = Room ambient as defined in 4.5 of MIL-STD-750;  $V_{CB}$  = 10-30 V dc; Power shall be applied to achieve  $T_J$  = 135°C minimum and a minimum power dissipation = 75 % of maximum rated  $P_T$  (see 1.3).

NOTE: No heat sink or forced air cooling on the devices shall be permitted.

4.3.2 Thermal impedance ( $Z_{\theta JX}$  measurements). The  $Z_{\theta JX}$  measurements shall be performed in accordance with MIL-STD-750, Method 3131.

- a.  $I_M$  measurement current..... 10 mA.
- b.  $I_H$  forward heating current ..... 500 mA (min).
- c.  $t_H$  heating time ..... 25 - 30 ms.
- d.  $t_{md}$  measurement delay time..... 60  $\mu$ s max.
- e.  $V_{CE}$  collector-emitter voltage ..... 10 V dc minimum

The maximum limit for  $Z_{\theta JX}$  under these test conditions are  $Z_{\theta JX} (max) = 17.5^\circ\text{C/W}$ .

4.4 Conformance inspection. Conformance inspection shall be in accordance with MIL-PRF-19500, and as specified herein. If alternate screening is being performed in accordance with E.5.3.1d of MIL-PRF-19500, a sample of screened devices shall be submitted to and pass the requirements of group A1 and A2 inspection only (table VIb, group B, subgroup 1 is not required to be performed again if group B has already been satisfied in accordance with 4.4.2).

4.4.1 Group A inspection. Group A inspection shall be conducted in accordance with MIL-PRF-19500, and table I herein.

4.4.2 Group B inspection. Group B inspection shall be conducted in accordance with the conditions specified for subgroup testing in table VIa (JANS) of MIL-PRF-19500 and 4.4.2.1. See 4.4.2.2 for JAN, JANTX, and JANTXV group B testing. Electrical measurements (end-points) shall be in accordance with table I, group A, subgroup 2.

4.4.2.1 Group B inspection, table VIa (JANS) of MIL-PRF-19500.

<u>Subgroup</u>	<u>Method</u>	<u>Condition</u>
B3	2037	Test condition A
B4	1037	$V_{CB} = 10$ V dc
B5	1027	$V_{CB} = 10$ V dc; $T_A = +125^\circ\text{C} \pm 25^\circ\text{C}$ for 96 hours adjusted as required according to the chosen $T_A$ to give a $T_J = +275^\circ\text{C}$ minimum. Optionally, the test may be conducted for minimum 216 hours with $P_T$ adjusted to achieve $T_J = 225^\circ\text{C}$ minimum, sample size (for option) = 45, c = 0. In this case, the ambient temperature shall be adjusted such that a minimum 100% of maximum rated $P_T$ (see 1.3) is applied to the device under test. (Note: If a failure occurs, resubmission shall be at the test conditions of the original sample.)
B6	3131	See 4.5.2

4.4.2.2 Group B inspection, (JAN, JANTX, and JANTXV). Separate samples may be used for each step. In the event of a group B failure, the manufacturer may pull a new sample at double size from either the failed assembly lot or from another assembly lot from the same wafer lot. If the new "assembly lot" option is exercised, the failed assembly lot shall be scrapped.

Step	Method	Condition
1	1039	HTRB, test condition A, $T_A = 150^\circ\text{C}$ , $V_{CB} = 80$ percent of para 1.3 rated, 340 hours, $n = 22$ devices, $c = 0$ .
2	1039	Steady-state life: Test condition B, 1,000 hours, $V_{CB} = 10 - 30$ V dc, Power shall be applied to achieve $T_J = 150^\circ\text{C}$ minimum and a minimum power dissipation $P_D = 75\%$ of $P_T$ maximum rated as defined in 1.3 herein.
	or	$n = 45$ devices, $\text{Acc} = 0$
	1037	Intermittent operation life: $V_{CB} = 10$ V dc, 6,000 cycles, $\Delta T_J \geq +100^\circ\text{C}$ ; forced air cooling allowed on cooling cycle only. $n = 45$ devices, $c = 0$ .
3	2037	Bond strength, test condition A, $n = 11$ wires, $c = 0$ .
4	1032	High-Temperature life (non-operating), $T_A = +200^\circ\text{C}$ $n = 22$ , $c = 0$

4.4.2.3 Group B sample selection. Samples selected from group B inspection shall meet all of the following requirements:

- a. Samples shall be selected from each wafer from a die fabrication line that the manufacturer chooses to "certify" for the die design used in products manufactured to this specification.
- b. Must be chosen from an inspection lot that has been submitted to and passed group A conformance inspection. When the final lead finish is solder or any plating prone to oxidation at high temperature, the samples for life test (subgroups B3 and B5 for JANS, and group B for JAN, JANTX, and JANTXV) may be pulled prior to the application of final lead finish.

4.4.2.4 Product acceptable for delivery. The product shall be acceptable for delivery only after the successful completion of all group B testing and shall be comprised of die meeting the following requirements:

- a. Manufactured on the same certified die fabrication line as the sample selected for 4.4.2.3.
- b. The die lot was manufactured (using start or completion dates, as the manufacturer selects to consistently use) within three months following the wafer lot used for sample selection in 4.4.2.3. Group B shall not be required more than once for any single wafer lot.

4.4.3 Group C inspection. Group C inspection shall be conducted in accordance with the conditions specified for subgroup testing in table VII of MIL-PRF-19500, and in 4.4.3.1 (JANS).and 4.4.3.2 (JAN, JANTX, and JANTXV) herein for group C testing. Electrical measurements (end points) and delta requirements shall be in accordance with group A, subgroup 2 herein.

4.4.3.1 Group C inspection, table VII (JANS) of MIL-PRF-19500.

Subgroup	Method	Condition
C2	2036	Test condition E.
C6	1026	Conditions: 1,000 hours at $V_{CB} = 10 - 30$ V dc; Power shall be applied to achieve $T_J = 150^\circ\text{C}$ minimum and a minimum power dissipation $P_D = 75\%$ of $P_T$ maximum rated as defined in 1.3 herein.

4.4.3.2 Group C inspection, table VII (JAN, JANTX, and JANTXV) of MIL-PRF-19500.

Subgroup	Method	Condition
C2	2036	Test condition E.
C6		Not Applicable

4.4.3.3 Group C sample selection. Samples for subgroups in group C shall be chosen at random from any inspection lot containing the intended package type and lead finish procured to the same specification which is submitted to and passes group A tests for conformance inspection. Testing of a subgroup using a single device type enclosed in the intended package type shall be considered as complying with the requirements for that subgroup.

4.4.3.4 Product acceptable for delivery. The product which may be accepted for delivery based a successful completion of group C testing shall be product of the particular package type with lot inspection identification codes of the 52 successive weeks beginning with the inspection lot identification code of the successful group C sample (i.e. the inspection lot identification codes accepted for delivery based on successful group C testing will include those sealed during the approximate 10 weeks during which the sample was being screened and tested plus those sealed in the 42 weeks following successful completion of group C testing making a total of 52 successive calendar weeks.) A manufacturer shall not accept product for delivery until after successful completion of the group C testing on product of the applicable package type with an inspection lot identification code less than 51 weeks prior to the inspection identification code of the product being considered for acceptance.

4.5 Method of inspection. Methods of inspection shall be as specified in the appropriate tables and as follows.

4.5.1 Pulse measurements. Conditions for pulse measurement shall be as specified in section 4 of MIL-STD-750.

4.5.2 Thermal resistance. Thermal resistance measurements shall be conducted in accordance with method 3131 of MIL-STD-750. The following details shall apply:

- a. Minimum collector current magnitude during power application shall be 160 mA dc for  $R_{\theta JC}$  and 32 mA dc for  $R_{\theta JA}$ .
- b. Collector to base voltage magnitude shall be 10 V dc.
- c. Reference temperature measuring point shall be the case for  $R_{\theta JC}$  and ambient air for  $R_{\theta JA}$ .
- d. Reference point temperature shall be selected with  $25^{\circ} \leq T_R \leq 35^{\circ}\text{C}$  and recorded before test is started.
- e. Mounting arrangement shall be with heat sink to case for  $R_{\theta JC}$  and without heat sink for  $R_{\theta JA}$ .
- f. Maximum limits shall be  $R_{\theta JC} = 35^{\circ}\text{C/W}$  and  $R_{\theta JA} = 175^{\circ}\text{C/W}$ .

NOTE: Unless otherwise specified by the acquiring activity, the choice for measuring  $R_{\theta JC}$  or  $R_{\theta JA}$  will satisfy the requirements of this test.



MIL-PRF-19500/349E

TABLE I. Group A inspection.

Inspection <u>1/</u> , <u>2/</u>	MIL-STD-750		Symbol	Limit		Unit
	Method	Conditions		Min	Max	
<u>Subgroup 1</u> <u>3/</u>						
Visual and mechanical <u>4/</u> examination	2071	n = 45 devices, c = 0				
Solderability <u>4/</u> , <u>6/</u>	2026	n = 15 leads, c = 0				
Resistance to solvents <u>4/</u> , <u>5/</u> , <u>6/</u>	1022	n = 15 devices, c = 0				
Temp Cycling <u>4/</u> , <u>6/</u>	1051	Test condition C, 25 cycles. n = 22 devices, c = 0				
Hermetic Seal <u>6/</u> Fine leak Gross leak	1071	n = 22 devices, c = 0				
Electrical measurements <u>6/</u>		Group A, subgroup 2				
Bond strength <u>4/</u> , <u>6/</u>	2037	Precondition T <sub>A</sub> = +250°C at t = 24 hrs or T <sub>A</sub> = 300°C at t = 2 hrs n = 11 wires, c = 0				
<u>Subgroup 2</u>						
Breakdown voltage collector to base 2N3506 2N3507	3001	Bias condition D, I <sub>C</sub> = 100 μA dc	V <sub>(BR)CBO</sub>	60 80		V dc V dc
Breakdown voltage emitter to base	3026	Bias condition D, I <sub>E</sub> = 10 μA dc	V <sub>(BR)EBO</sub>	5		V dc
Breakdown voltage collector to emitter 2N3506 2N3507	3011	Bias condition D, I <sub>C</sub> = 10 mA dc, pulsed (see 4.5.1)	V <sub>(BR)CEO</sub>	40 50		V dc V dc
Collector to emitter cutoff current 2N3506 2N3507	3041	Bias condition A, V <sub>EB</sub> = 4 V dc V <sub>CE</sub> = 40 V dc V <sub>CE</sub> = 60 V dc	I <sub>CEX1</sub>		1	μA dc
Forward-current transfer ratio 2N3506 2N3507	3076	V <sub>CE</sub> = 1 V dc, I <sub>C</sub> = 500 mA dc, pulsed (see 4.5.1)	h <sub>FE1</sub>	50 35	250 175	
Forward-current transfer ratio 2N3506 2N3507	3076	V <sub>CE</sub> = 2 V dc, I <sub>C</sub> = 1.5 A dc, pulsed (see 4.5.1)	h <sub>FE2</sub>	40 30	200 150	

See footnotes at end of table.

MIL-PRF-19500/349E

TABLE I. Group A inspection.

Inspection 1/, 2/	MIL-STD-750		Symbol	Limit		Unit
	Method	Conditions		Min	Max	
<u>Subgroup 2</u> - Continued						
Forward-current transfer ratio 2N3506 2N3507	3076	$V_{CE} = 3 \text{ V dc}$ , $I_C = 2.5 \text{ A dc}$ , pulsed (see 4.5.1)	$h_{FE3}$	30 25		
Forward-current transfer ratio 2N3506 2N3507	3076	$V_{CE} = 5 \text{ V dc}$ , $I_C = 3.0 \text{ A dc}$ , pulsed (see 4.5.1)	$h_{FE4}$	25 20		
Saturation voltage and resistance	3071	$I_C = 500 \text{ mA dc}$ , $I_B = 50 \text{ mA dc}$ , pulsed (see 4.5.1)	$V_{CE(sat)1}$		0.5	V dc
Saturation voltage and resistance	3071	$I_C = 1.5 \text{ A dc}$ , $I_B = 150 \text{ mA dc}$ , pulsed (see 4.5.1)	$V_{CE(sat)2}$		1.0	V dc
Saturation voltage and resistance	3071	$I_C = 2.5 \text{ A dc}$ , $I_B = 250 \text{ mA dc}$ , pulsed (see 4.5.1)	$V_{CE(sat)3}$		1.5	V dc
Base to emitter saturated voltage	3066	Test condition A, $I_C = 500 \text{ mA dc}$ , $I_B = 50 \text{ mA dc}$ , pulsed (see 4.5.1)	$V_{BE(sat)1}$		1.0	V dc
Base to emitter saturated voltage	3066	Test condition A, $I_C = 1.5 \text{ A dc}$ , $I_B = 150 \text{ mA dc}$ , pulsed (see 4.5.1)	$V_{BE(sat)2}$	0.8	1.3	V dc
Base to emitter saturated voltage	3066	Test condition A, $I_C = 2.5 \text{ A dc}$ , $I_B = 250 \text{ mA dc}$ , pulsed (see 4.5.1)	$V_{BE(sat)3}$		2.0	V dc
<u>Subgroup 3</u>						
High-temperature operation		$T_A = +150^\circ\text{C}$				
Collector to emitter cutoff current 2N3506 2N3507	3041	Bias condition A, $V_{EB} = 4 \text{ V dc}$  $V_{CE} = 40 \text{ V dc}$ $V_{CE} = 60 \text{ V dc}$	$I_{CEX2}$		1.5	mA dc
Low-temperature operation		$T_A = -55^\circ\text{C}$				
Forward-current transfer ratio 2N3506, 2N3506L 2N3507, 2N3507L 2N3506A, 2N3506AL 2N3507A, 2N3507AL	3076	$I_C = 500 \text{ mA dc}$ , pulsed (see 4.5.1) $V_{CE} = 1.0 \text{ V dc}$ $V_{CE} = 1.0 \text{ V dc}$ $V_{CE} = 2.0 \text{ V dc}$ $V_{CE} = 2.0 \text{ V dc}$	$h_{FE5}$	25 17 25 17		

See footnote at end of table.

MIL-PRF-19500/349E

TABLE I. Group A inspection.

Inspection 1/, 2/	MIL-STD-750		Symbol	Limit		Unit
	Method	Conditions		Min	Max	
<u>Subgroup 4</u>						
Small-signal short-circuit forward-current transfer ratio	3206	$V_{CE} = 5 \text{ V dc}, I_C = 100 \text{ mA dc}, f = 20 \text{ MHz}$	$ h_{fe} $	3	15	
Open circuit output capacitance	3236	$V_{CB} = 10 \text{ V dc}, I_E = 0, 100 \text{ kHz} \leq f \leq 1 \text{ MHz}$	$C_{obo}$		40	pF
Input capacitance (output open-circuited)	3240	$V_{EB} = 3 \text{ V dc}, I_C = 0, 100 \text{ kHz} \leq f \leq 1 \text{ MHz}$	$C_{ibo}$		300	pF
Pulse response:						
Delay time	3251	Test condition A, $I_C = 1.5 \text{ A dc}, I_{B1} = 150 \text{ mA dc}$ , (see figure 3)	$t_d$		15	ns
Rise time	3251	Test condition A, $I_C = 1.5 \text{ A dc}, I_{B1} = 150 \text{ mA dc}$ , (see figure 3)	$t_r$		30	ns
Storage time	3251	Test condition A, $I_C = 1.5 \text{ A dc}, I_{B1} = I_{B2} = 150 \text{ mA dc}$ , (see figure 4)	$t_s$		55	ns
Fall time	3251	Test condition A, $I_C = 1.5 \text{ A dc}, I_{B1} = I_{B2} = 150 \text{ mA dc}$ , (see figure 4)	$t_f$		35	ns

1/ For sampling plan see MIL-PRF-19500.

2/ Electrical characteristics for "A", "AL", and "L" suffix devices are identical to non suffix devices unless otherwise noted.

3/ For resubmission of failed subgroup A1, double the sample size of the failed test or sequence of tests. A failure in group A, subgroup 1 shall not require retest of the entire subgroup. Only the failed test shall be rerun upon submission.

4/ Separate samples may be used.

5/ Not required for laser marked devices.

6/ Not required for JANS devices.

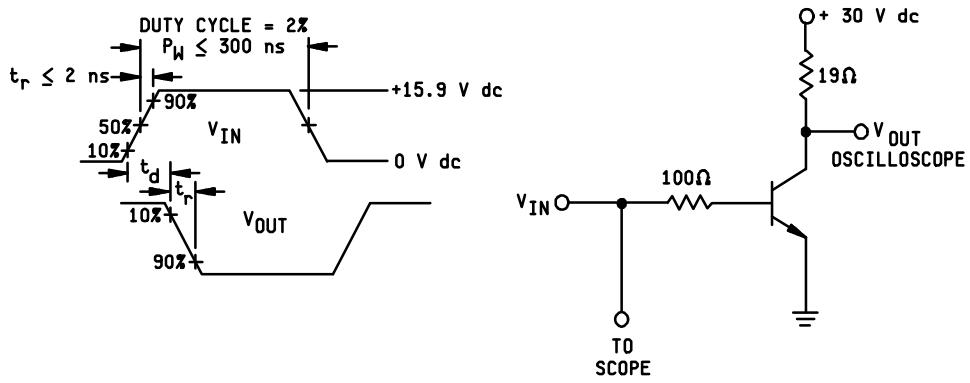

FIGURE 3. Equivalent circuit for measuring delay and rise times.

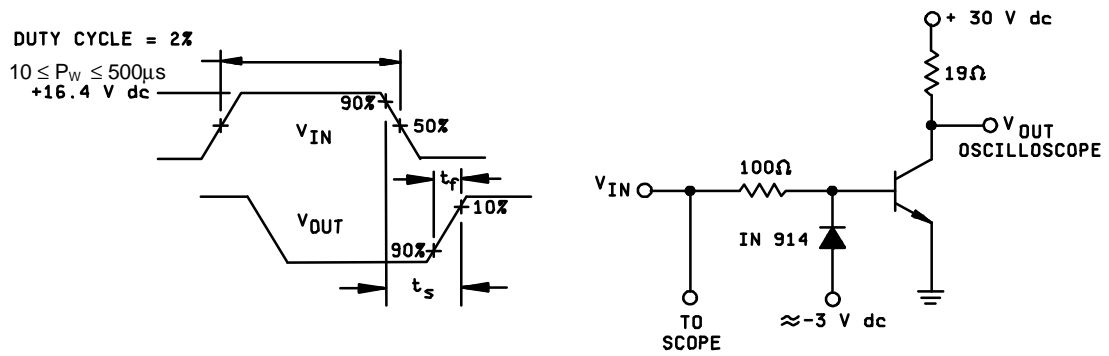

FIGURE 4. Equivalent circuit for measuring storage and fall times.

5. PACKAGING

5.1 Packaging. For acquisition purposes, the packaging requirements shall be as specified in the contract or order (see 6.2). When actual packaging of materiel is to be performed by DoD personnel, these personnel need to contact the responsible packaging activity to ascertain requisite packaging requirements. Packaging requirements are maintained by the Inventory Control Point's packaging activity within the Military Department or Defense Agency, or within the Military Department's System Command. Packaging data retrieval is available from the managing Military Department's or Defense Agency's automated packaging files, CD-ROM products, or by contacting the responsible packaging activity.

6. NOTES

(This section contains information of a general or explanatory nature that may be helpful, but is not mandatory.)

6.1 Intended use. The notes specified in MIL-PRF-19500 are applicable to this specification.

6.2 Acquisition requirements. Acquisition documents should specify the following:

- a. Lead finish as specified (see 3.3.1).
- b. Type designation and product assurance level.

6.3 Substitution information. The 2N3506A and 2N3507A may be substituted for the 2N3506 and 2N3507 (and L suffix versions) (respectively) at the discretion of the procuring activity."

6.4 Changes from previous issue. Marginal notations are not used in this revision to identify changes with respect to the previous issue due to the extensiveness of the changes.

6.5 Qualification. With respect to products requiring qualification, awards will be made only for products which are, at the time of award of contract, qualified for inclusion in Qualified Manufacturers' List (QML) whether or not such products have actually been so listed by that date. The attention of the contractors is called to these requirements, and manufacturers are urged to arrange to have the products that they propose to offer to the Federal Government tested for qualification in order that they may be eligible to be awarded contracts or orders for the products covered by this specification. Information pertaining to qualification of products may be obtained from Defense Supply Center, Columbus, ATTN: DSCC-VQE, P.O. Box 3990, Columbus, Ohio, 43216-5000.

Custodians:

Army - CR  
Navy - EC  
Air Force - 11  
NASA - NA

Preparing activity:  
DLA - CC

(Project 5961-2308)

Review activities:

Army - AR, AV, MI  
Navy - AS, CG, MC  
Air Force - 13, 19

