

POWER TRANSISTORS

5 Amp, 300V, Planar NPN

JAN, JANTX, & JANTXV 2N5664
 JAN, JANTX, & JANTXV 2N5665
 JAN, JANTX, & JANTXV 2N5666
 JAN, JANTX, & JANTXV 2N5667

FEATURES

- Meets MIL-S-19500/455
- Collector-Base Voltage: up to 400V
- D.C. Collector Current: 5A
- Peak Collector Current: 10A
- Fast Switching

DESCRIPTION

Unitrode high voltage transistors provide a unique combination of low saturation voltage, fast switching, and excellent gain. They are ideally suited for off-line power supply designs and other applications where the increased voltage rating adds to system reliability.

ABSOLUTE MAXIMUM RATINGS

	JAN, JANTX, & JANTXV	JAN, JANTX, & JANTXV	JAN, JANTX, & JANTXV	JAN, JANTX, & JANTXV
	2N5664	2N5665	2N5666	2N5667
Collector-Base Voltage, V_{CB0}	250V	400V	250V	400V
Collector-Emitter Voltage, V_{CEO}	200V	300V	200V	300V
Emitter-Base Voltage, V_{EBO}	6V	6V	6V	6V
D.C. Collector Current, I_C	5A	5A	5A	5A
Peak Collector Current, I_C	10A	10A	10A	10A
Power Dissipation				
25°C Ambient	2.5W	2.5W	1.2W	1.2W
100°C Case	30W	30W	15W	15W
Operating and Storage Temperature Range	-65°C to 200°C			

MECHANICAL SPECIFICATIONS

JAN, JANTX, & JANTXV 2N5664 JAN, JANTX, & JANTXV 2N5665

	INCHES	MILLIMETERS
A	.620 MAX.	15.75 MAX.
B	.050 - .075	1.27 - 1.90
C	.250 - .340	6.35 - 8.63
D	.360 MIN.	9.14 MIN.
E	.028 - .034 DIA.	.711 - .863
F	.958 - .962	24.33 - 24.43
G	.570 - .590	14.47 - 14.98
H	.145 MAX. RAD.	3.68 MAX. RAD.
J	.142 - .152 DIA.	3.60 - 3.86 DIA.
K	.350 MAX. RAD.	8.89 MAX. RAD.
L	.190 - .210	4.82 - 5.33
M	.093 - .107	2.36 - 2.72

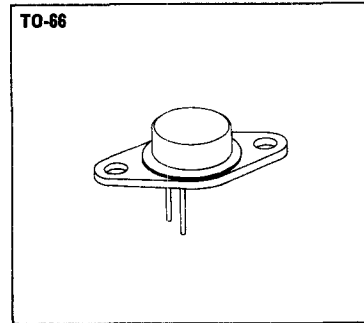

JAN, JANTX, & JANTXV 2N5666 JAN, JANTX, & JANTXV 2N5667

	INCHES	MILLIMETERS
A	.335 - .370	8.51 - 9.40
B	.305 - .335	7.76 - 8.51
C	.240 - .260	6.09 - 6.60
D	1.5 MIN.	38.10 MIN.
E	.010 - .030	254 - 762
F	.017 ± .002 .001	432 ± .051 .025
G	.200	5.08
H	.100	2.54
J	.031 ± .003	787 ± .076
K	.029 - .045	736 - 1.14
L	.100	2.54

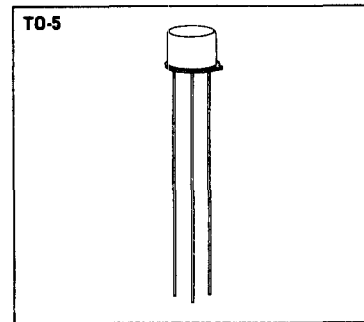

ELECTRICAL SPECIFICATIONS (at 25°C unless noted)
2N5664, 2N5666

Test	Symbol	Min.	Max.	Units	/455 Sub group	MIL-STD-750		
						Method	Test conditions	
Visual and mechanical					A-1	2071	See Mechanical Data	
25°C								
Collector-Emitter Breakdown Voltage (Note 1)	BV_{CE}^*	250	—	Vdc	A-2	3011	$I_C = 10\text{mA}$; $R_{BE} = 100\Omega$; Cond. B	
Collector-Emitter Breakdown Voltage (Note 1)	BV_{CEO}^*	200	—	Vdc	A-2	3011	$I_C = 10\text{mA}$; Cond. D	
Emitter-Base Breakdown Voltage	BV_{EBO}^*	6.0	—	Vdc	A-2	3026	$I_E = 10\mu\text{A}$; Cond. D	
Collector-Emitter Cutoff Current	I_{CES}^*	—	0.2	μA	A-2	3041	$V_{CE} = 200\text{Vdc}$; Cond. C	
Collector-Base Cutoff Current	I_{CBO}	—	0.1	μA	A-2	3036	$V_{CB} = 200\text{Vdc}$; Cond. D	
Collector-Base Cutoff Current	I_{CBO}	—	1.0	mA	A-2	3036	$V_{CB} = 250\text{Vdc}$; Cond. D	
D.C. Current Gain (Note 1)	h_{FE}^*	40	—	—	A-3	3076	$I_C = 0.5\text{A}$; $V_{CE} = 2\text{Vdc}$	
D.C. Current Gain (Note 1)	h_{FE}^*	40	120	—	A-3	3076	$I_C = 1\text{A}$; $V_{CE} = 5\text{Vdc}$	
D.C. Current Gain (Note 1)	h_{FE}^*	15	—	—	A-3	3076	$I_C = 3\text{A}$; $V_{CE} = 5\text{Vdc}$	
D.C. Current Gain (Note 1)	h_{FE}	5	—	—	A-3	3076	$I_C = 5\text{A}$; $V_{CE} = 5\text{Vdc}$	
Collector Saturation Voltage (Note 1)	$V_{CE}(\text{sat})^*$	—	0.4	Vdc	A-3	3071	$I_C = 3\text{A}$; $I_B = 0.3\text{A}$	
Collector Saturation Voltage (Note 1)	$V_{CE}(\text{sat})$	—	1.0	Vdc	A-3	3071	$I_C = 5\text{A}$; $I_B = 1\text{A}$	
Base Saturation Voltage (Note 1)	$V_{BE}(\text{sat})^*$	—	1.2	Vdc	A-3	3066	$I_C = 3\text{A}$; $I_B = 0.3\text{A}$; Cond. A	
Base Saturation Voltage (Note 1)	$V_{BE}(\text{sat})$	—	1.5	Vdc	A-3	3066	$I_C = 5\text{A}$; $I_B = 1\text{A}$; Cond. A	
Gain-Bandwidth Product	f_T^*	20	70	MHz	A-4	3306	$I_C = 0.5\text{A}$; $V_{CE} = 5\text{Vdc}$; $f = 10\text{MHz}$	
Output Capacitance	C_{ob}	—	120	pf	A-4	3236	$V_{CE} = 10\text{Vdc}$; $I_C = 0$; $f = 1\text{MHz}$	
Thermal Resistance	θ_{J-C}				C-1	3151		
2N5664		—	3.3	$^{\circ}\text{C}/\text{W}$				
2N5666		—	6.7	$^{\circ}\text{C}/\text{W}$				
Switching Speeds	Turn-on Time	t_{on}^*	—	0.25	μs	A-4	—	$I_C = 1\text{A}$
	Turn-off Time	t_{off}^*	—	1.5	μs	A-4	—	
100°C								
Forward Biased Second Breakdown 2N5664	$I_{S/B}$	5	—	A	B-6	3051	$V_{CE} = 6\text{Vdc}$; $t = 1\text{sec}$	
	$I_{S/B}$	0.75	—	A	B-6	3051	$V_{CE} = 40\text{Vdc}$; $t = 1\text{sec}$	
2N5666	$I_{S/B}$	43	—	mA	B-6	3051	$V_{CE} = 200\text{Vdc}$; $t = 1\text{sec}$	
	$I_{S/B}$	5	—	A	B-7	3051	$V_{CE} = 3\text{Vdc}$; $t = 1\text{sec}$	
	$I_{S/B}$	0.4	—	A	B-7	3051	$V_{CE} = 37.5\text{Vdc}$; $t = 1\text{sec}$	
	$I_{S/B}$	27	—	mA	B-7	3051	$V_{CE} = 200\text{Vdc}$; $t = 1\text{sec}$	
Unclamped Reverse Biased Second Breakdown	$E_{S/B}$	1.25	—	mJ	B-8	3053	$I_C = 5\text{A}$; $L = 0.1\text{mH}$	
Clamped Reverse Biased Second Breakdown	$E_{S/B}$	500	—	mJ	B-9	3053	$I_C = 5\text{A}$; $L = 40\text{mH}$; $V_{CLAMP} = 200\text{V}$	
150°C								
Collector-Emitter Cutoff Current	I_{CES}^*	—	100	μA	A-5	3041	$V_{CE} = 200\text{Vdc}$; Cond. C	
-65°C								
D.C. Current Gain (Note 1)	h_{FE}	15	—	—	A-6	3076	$I_C = 1\text{A}$; $V_{CE} = 5\text{Vdc}$	



Notes:

1. Pulse width = 300 μs ; duty cycle $\leq 2\%$.

* Those parameters marked with a * are JEDEC registered and devices meeting these specifications are available as commercial 2N devices.

ELECTRICAL SPECIFICATIONS (at 25°C unless noted)
2N5665, 2N5667

Test	Symbol	Min.	Max.	Units	/455 Sub group	MIL-STD-750	
						Method	Test conditions
Visual and mechanical					A-1	2071	See Mechanical Data
25°C							
Collector-Emitter Breakdown Voltage (Note 1)	BV_{CE}^*	400	—	Vdc	A-2	3011	$I_C = 10\text{mAdc}$; $R_{BE} = 100\ \Omega$, Cond. B
Collector-Emitter Breakdown Voltage (Note 1)	BV_{CE0}^*	300	—	Vdc	A-2	3011	$I_C = 10\text{mAdc}$; Cond. D
Emitter-Base Breakdown Voltage	BV_{EB0}^*	6	—	Vdc	A-2	3026	$I_E = 10\ \mu\text{Adc}$; Cond. D
Collector-Emitter Cutoff Current	I_{CES}^*	—	0.2	μAdc	A-2	3041	$V_{CE} = 300\text{Vdc}$; Cond. C
Collector-Base Cutoff Current	I_{CBC}	—	0.1	μAdc	A-2	3036	$V_{CB} = 300\text{Vdc}$; Cond. D
Collector-Base Cutoff Current	I_{CBO}	—	1.0	mAdc	A-2	3036	$V_{CB} = 400\text{Vdc}$; Cond. D
D.C. Current Gain (Note 1)	h_{FE}^*	25	—	—	A-3	3076	$I_C = 0.5\text{Adc}$, $V_{CE} = 2\text{Vdc}$
D.C. Current Gain (Note 1)	h_{FE}^*	25	75	—	A-3	3076	$I_C = 1\text{Adc}$, $V_{CE} = 5\text{Vdc}$
D.C. Current Gain (Note 1)	h_{FE}^*	10	—	—	A-3	3076	$I_C = 3\text{Adc}$, $V_{CE} = 5\text{Vdc}$
D.C. Current Gain (Note 1)	h_{FE}	5	—	—	A-3	3076	$I_C = 5\text{Adc}$, $V_{CE} = 5\text{Vdc}$
Collector Saturation Voltage (Note 1)	$V_{CE}(\text{sat})^*$	—	0.4	Vdc	A-3	3071	$I_C = 3\text{Adc}$, $I_B = 0.6\text{Adc}$
Collector Saturation Voltage (Note 1)	$V_{CE}(\text{sat})$	—	1.0	Vdc	A-3	3071	$I_C = 5\text{Adc}$, $I_B = 1\text{Adc}$
Base Saturation Voltage (Note 1)	$V_{BE}(\text{sat})^*$	—	1.2	Vdc	A-3	3066	$I_C = 3\text{Adc}$, $I_B = 0.6\text{Adc}$; Cond. A
Base Saturation Voltage (Note 1)	$V_{BE}(\text{sat})$	—	1.5	Vdc	A-3	3066	$I_C = 5\text{Adc}$, $I_B = 1\text{Adc}$; Cond. A
Gain-Bandwidth Product	f_T^*	20	70	MHz	A-4	3306	$I_C = 0.5\text{Adc}$, $V_{CE} = 5\text{Vdc}$, $f = 10\text{MHz}$
Output Capacitance	C_{ob}	—	90	pf	A-4	3236	$V_{CB} = 10\text{Vdc}$, $I_E = 0$, $f = 1\text{MHz}$
Thermal Resistance	θ_{J-C}				C-1	3151	
2N5665		—	3.3	°C/W			
2N5667		—	6.7	°C/W			
Switching Speeds	Turn-on time	t_{on}^*	—	0.25	μs	A-4	—
	Turn-off time	t_{off}^*	—	2.0	μs	A-4	—
100°C							
Forward Biased Second Breakdown 2N5665	$I_{S/B}$	5	—	Adc	B-6	3051	$V_{CE} = 6\text{Vdc}$, $t = 1\text{sec}$
	$I_{S/B}$	0.75	—	Adc	B-6	3051	$V_{CE} = 40\text{Vdc}$, $t = 1\text{sec}$
	$I_{S/B}$	21	—	mAdc	B-6	3051	$V_{CE} = 300\text{Vdc}$, $t = 1\text{sec}$
2N5667	$I_{S/B}$	5	—	Adc	B-7	3051	$V_{CE} = 3\text{Vdc}$, $t = 1\text{sec}$
	$I_{S/B}$	0.4	—	Adc	B-7	3051	$V_{CE} = 37.5\text{Vdc}$, $t = 1\text{sec}$
	$I_{S/B}$	14	—	nAdc	B-7	3051	$V_{CE} = 300\text{Vdc}$, $t = 1\text{sec}$
Unclamped Reverse Biased Second Breakdown	$E_{S/B}$	1.25	—	mj	B-8	3053	$I_C = 5\text{Adc}$, $L = 0.1\text{mh}$
Clamped Reverse Biased Second Breakdown	$E_{S/B}$	500	—	mj	B-9	3053	$I_C = 5\text{Adc}$, $L = 40\text{mh}$, $V_{clamp} = 300\text{V}$
150°C							
Collector-Emitter Cutoff Current	I_{CES}^*	—	100	μAdc	A-5	3041	$V_{CE} = 300\text{Vdc}$, Cond. C
-65°C							
D.C. Current Gain (Note 1)	h_{FE}	10	—	—	A-6	3076	$I_C = 1\text{Adc}$, $V_{CE} = 5\text{Vdc}$

Notes:

1. Pulse width = 300 μs ; duty cycle $\leq 2\%$.

* Those parameters marked with a * are JEDEC registered and devices meeting these specifications are available as commercial 2N devices.

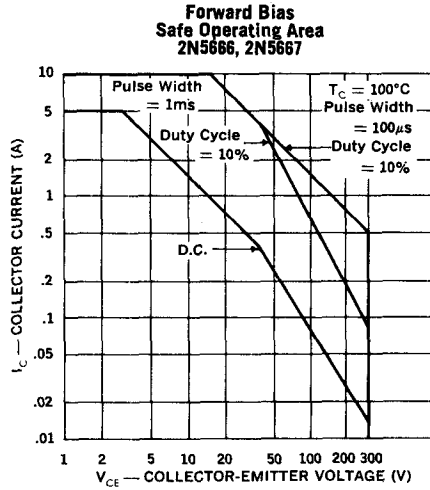
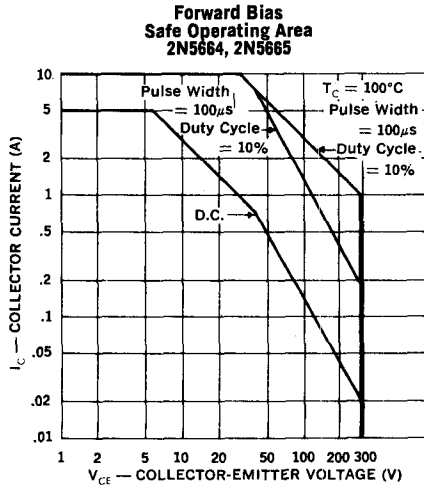

IV

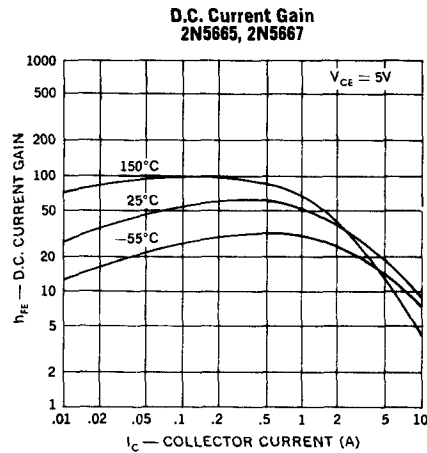
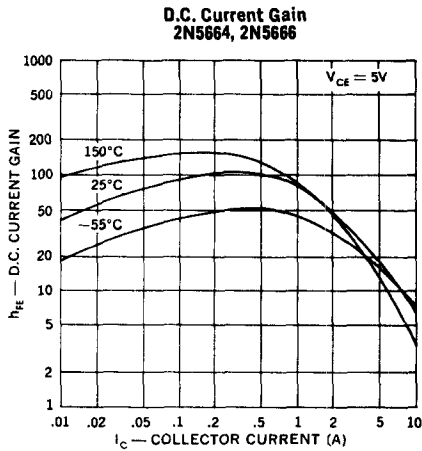
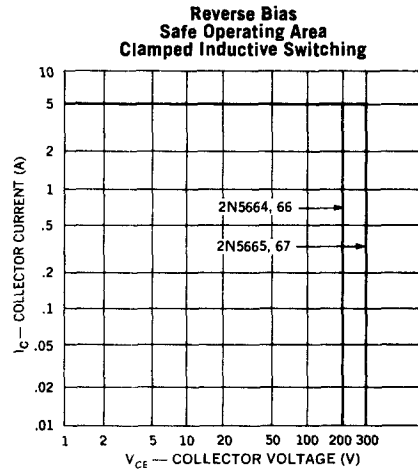
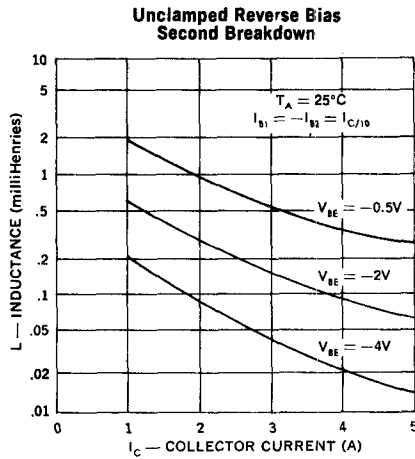

Saturation Voltages

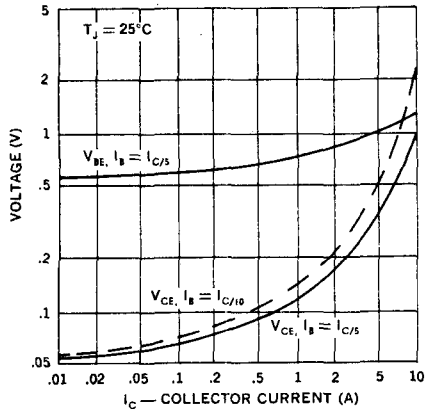

Saturation Voltage Temperature Coefficients

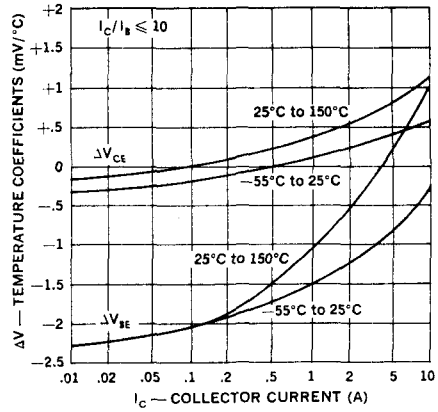

Switching Speed Characteristics

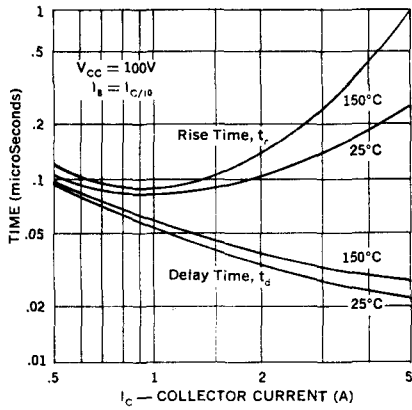

Switching Speed Characteristics

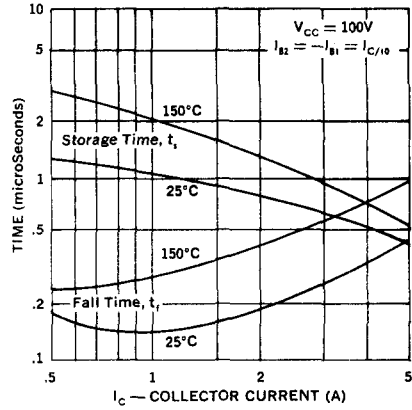

Switching Speed Circuits

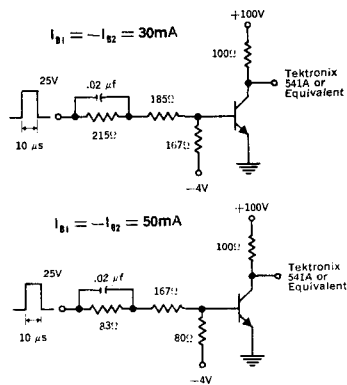

Thermal Response

