

3 MHz, Micropower RRO Amplifiers

General Description

The LMV551/LMV552/LMV554 are high performance, low power operational amplifiers implemented with National's advanced VIP50 process. They feature 3 MHz of bandwidth while consuming only 37 μ A of current per amplifier, which is an exceptional bandwidth to power ratio in this op amp class. These amplifiers are unity gain stable and provide an excellent solution for low power applications requiring a wide bandwidth.

The LMV551/LMV552/LMV554 have a rail-to-rail output stage and an input common mode range that extends below ground.

The LMV551/LMV552/LMV554 have an operating supply voltage range from 2.7V to 5.5V. These amplifiers can operate over a wide temperature range (-40°C to 125°C) making them a great choice for automotive applications, sensor applications as well as portable instrumentation applications. The LMV551 is offered in the ultra tiny 5-Pin SC70 and 5-Pin SOT-23 package. The LMV552 is offered in an 8-Pin MSOP package. The LMV554 is offered in the 14-Pin TSSOP.

Typical Application

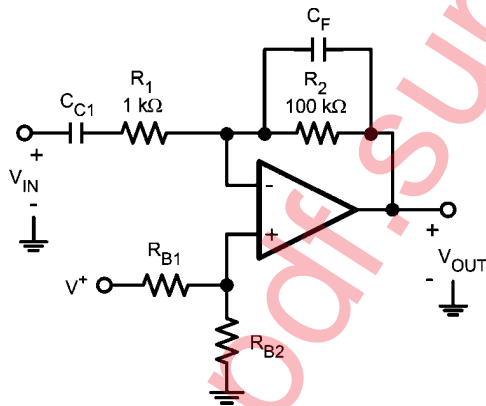

20152601

Features

(Typical 5V supply, unless otherwise noted.)

- Guaranteed 3V and 5.0V performance
- High unity gain bandwidth 3 MHz
- Supply current (per amplifier) 37 μ A
- CMRR 93 dB
- PSRR 90 dB
- Slew rate 1 V/ μ s
- Output swing with 100 k Ω load 70 mV from rail
- Total harmonic distortion 0.003% @ 1 kHz, 2 k Ω
- Temperature range -40°C to 125°C

Applications

- Active filter
- Portable equipment
- Automotive
- Battery powered systems
- Sensors and Instrumentation

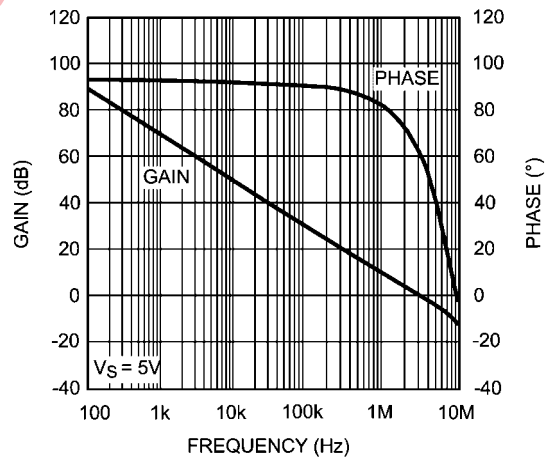

20152613

Open Loop Gain and Phase vs. Frequency

Absolute Maximum Ratings *(Note 1)*

If Military/Aerospace specified devices are required, please contact the Texas Instruments Sales Office/ Distributors for availability and specifications.

ESD Tolerance <i>(Note 2)</i>		
Human Body Model		
LMV551/LMV552/LMV554		2 KV
Machine Model		
LMV551		100V
LMV552/LMV554		250V
V_{IN} Differential (@ $V^+ = 5V$)		$\pm 2.5V$
Supply Voltage ($V^+ - V^-$)		6V
Voltage at Input/Output pins	$V^+ + 0.3V, V^- - 0.3V$	
Storage Temperature Range		$-65^\circ C$ to $150^\circ C$
Junction Temperature <i>(Note 3)</i>		$150^\circ C$
Soldering Information		
Infrared or Convection (20 sec)		$235^\circ C$
Wave Soldering Lead Temp. (10 sec)		$260^\circ C$

Operating Ratings *(Note 1)*

Temperature Range <i>(Note 3)</i>	$-40^\circ C$ to $125^\circ C$
Supply Voltage ($V^+ - V^-$)	2.7V to 5.5V
Package Thermal Resistance (θ_{JA}) <i>(Note 3)</i>	
5-Pin SC70	$456^\circ C/W$
5-Pin SOT-23	$234^\circ C/W$
8-Pin MSOP	$235^\circ C/W$
14-Pin TSSOP	$160^\circ C/W$

3V Electrical Characteristics

Unless otherwise specified, all limits are guaranteed for $T_A = 25^\circ C$, $V^+ = 3V$, $V^- = 0V$, $V_{CM} = V^+/2 = V_O$. **Boldface** limits apply at the temperature extremes. *(Note 4)*

Symbol	Parameter	Conditions	Min <i>(Note 6)</i>	Typ <i>(Note 5)</i>	Max <i>(Note 6)</i>	Units
V_{OS}	Input Offset Voltage			1	3 4.5	mV
$TC V_{OS}$	Input Offset Average Drift			3.3		$\mu V/^\circ C$
I_B	Input Bias Current	<i>(Note 7)</i>		20	38	nA
I_{OS}	Input Offset Current			1	20	nA
CMRR	Common Mode Rejection Ratio	$0V \leq V_{CM} \leq 2.0V$	74 72	92		dB
PSRR	Power Supply Rejection Ratio	$3.0 \leq V^+ \leq 5V,$ $V_{CM} = 0.5V$	LMV551/LMV552	80 78	92	dB
			LMV554	78 76		
		$2.7 \leq V^+ \leq 5.5V,$ $V_{CM} = 0.5V$	LMV551/LMV552	80 78	92	
			LMV554	78 76		
CMVR	Input Common-Mode Voltage Range	CMRR ≥ 68 dB CMRR ≥ 60 dB	0 0		2.1 2.1	V

Symbol	Parameter	Conditions	Min (Note 6)	Typ (Note 5)	Max (Note 6)	Units
A_{VOL}	Large Signal Voltage Gain	$0.4 \leq V_O \leq 2.6$, $R_L = 100 \text{ k}\Omega$ to $V+/2$	LMV551/LMV552	81 78	90	dB
			LMV554	79 77		
		$0.4 \leq V_O \leq 2.6$, $R_L = 10 \text{ k}\Omega$ to $V+/2$		71 68	80	
V_O	Output Swing High	$R_L = 100 \text{ k}\Omega$ to $V+/2$		40	48 58	mV from rail
		$R_L = 10 \text{ k}\Omega$ to $V+/2$		85	100 120	
	Output Swing Low	$R_L = 100 \text{ k}\Omega$ to $V+/2$		50	65 77	
		$R_L = 10 \text{ k}\Omega$ to $V+/2$		95	110 130	
I_{SC}	Output Short Circuit Current	Sourcing (Note 9)		10		mA
		Sinking (Note 9)		25		
I_S	Supply Current per Amplifier			34	42 52	μA
SR	Slew Rate	$A_V = +1$, 10% to 90% (Note 8)		1		$\text{V}/\mu\text{s}$
ϕ_m	Phase Margin	$R_L = 10 \text{ k}\Omega$, $C_L = 20 \text{ pF}$		75		Deg
GBW	Gain Bandwidth Product			3		MHz
e_n	Input-Referred Voltage Noise	$f = 100 \text{ kHz}$		70		$\text{nV}/\sqrt{\text{Hz}}$
		$f = 1 \text{ kHz}$		70		
i_n	Input-Referred Current Noise	$f = 100 \text{ kHz}$		0.1		$\text{pA}/\sqrt{\text{Hz}}$
		$f = 1 \text{ kHz}$		0.15		
THD	Total Harmonic Distortion	$f = 1 \text{ kHz}$, $A_V = 2$, $R_L = 2 \text{ k}\Omega$		0.003		%

5V Electrical Characteristics

Unless otherwise specified, all limits are guaranteed for $T_A = 25^\circ\text{C}$, $V^+ = 5\text{V}$, $V^- = 0\text{V}$, $V_{CM} = V+/2 = V_O$. **Boldface** limits apply at the temperature extremes.

Symbol	Parameter	Conditions	Min (Note 6)	Typ (Note 5)	Max (Note 6)	Units
V_{OS}	Input Offset Voltage			1	3.0 4.5	mV
TC V_{OS}	Input Offset Average Drift			3.3		$\mu\text{V}/^\circ\text{C}$
I_B	Input Bias Current	(Note 7)		20	38	nA
I_{OS}	Input Offset Current			1	20	nA
CMRR	Common Mode Rejection Ratio	$0 \leq V_{CM} \leq 4.0\text{V}$	76 74	93		dB
PSRR	Power Supply Rejection Ratio	$3\text{V} \leq V^+ \leq 5\text{V}$ to $V_{CM} = 0.5\text{V}$	78 75	90		dB
		$2.7\text{V} \leq V^+ \leq 5.5\text{V}$ to $V_{CM} = 0.5\text{V}$	78 75	90		
CMVR	Input Common-Mode Voltage Range	CMRR $\geq 68 \text{ dB}$ CMRR $\geq 60 \text{ dB}$	0 0		4.1 4.1	V
A_{VOL}	Large Signal Voltage Gain	$0.4 \leq V_O \leq 4.6$, $R_L = 100 \text{ k}\Omega$ to $V+/2$	78 75	90		dB
		$0.4 \leq V_O \leq 4.6$, $R_L = 10 \text{ k}\Omega$ to $V+/2$	75 72	80		

Symbol	Parameter	Conditions	Min (<i>Note 6</i>)	Typ (<i>Note 5</i>)	Max (<i>Note 6</i>)	Units
V_O	Output Swing High	$R_L = 100\text{ k}\Omega$ to $V+/2$		70	92 122	mV from rail
		$R_L = 10\text{ k}\Omega$ to $V+/2$		125	155 210	
	Output Swing Low	$R_L = 100\text{ k}\Omega$ to $V+/2$		60	70 82	
		$R_L = 10\text{ k}\Omega$ to $V+/2$		110	130 155	
I_{SC}	Output Short Circuit Current	Sourcing (<i>Note 9</i>)		10		mA
		Sinking (<i>Note 9</i>)		25		
I_S	Supply Current Per Amplifier			37	46 54	μA
SR	Slew Rate	$A_V = +1$, $V_O = 1\text{ V}_{PP}$ 10% to 90% (<i>Note 8</i>)		1		$\text{V}/\mu\text{s}$
Φ_m	Phase Margin	$R_L = 10\text{ k}\Omega$, $C_L = 20\text{ pF}$		75		Deg
GBW	Gain Bandwidth Product			3		MHz
e_n	Input-Referred Voltage Noise	$f = 100\text{ kHz}$		70		$\text{nV}/\sqrt{\text{Hz}}$
		$f = 1\text{ kHz}$		70		
i_n	Input-Referred Current Noise	$f = 100\text{ kHz}$		0.1		$\text{pA}/\sqrt{\text{Hz}}$
		$f = 1\text{ kHz}$		0.15		
THD	Total Harmonic Distortion	$f = 1\text{ kHz}$, $A_V = 2$, $R_L = 2\text{ k}\Omega$		0.003		%

Note 1: Absolute Maximum Ratings indicate limits beyond which damage to the device may occur. Operating Ratings indicate conditions for which the device is intended to be functional, but specific performance is not guaranteed. For guaranteed specifications and the test conditions, see the Electrical Characteristics Tables.

Note 2: Human Body Model, applicable std. MIL-STD-883, Method 3015.7. Machine Model, applicable std. JESD22-A115-A (ESD MM std. of JEDEC). Field-Induced Charge-Device Model, applicable std. JESD22-C101-C (ESD FICDM std. of JEDEC).

Note 3: The maximum power dissipation is a function of $T_{J(MAX)}$, θ_{JA} . The maximum allowable power dissipation at any ambient temperature is $P_D = (T_{J(MAX)} - T_A) / \theta_{JA}$. All numbers apply for packages soldered directly onto a PC board.

Note 4: Electrical Table values apply only for factory testing conditions at the temperature indicated. Factory testing conditions result in very limited self-heating of the device such that $T_J = T_A$. No guarantee of parametric performance is indicated in the electrical tables under conditions of internal self-heating where $T_J > T_A$.

Note 5: Typical values represent the most likely parametric norm as determined at the time of characterization. Actual typical values may vary over time and will also depend on the application and configuration. The typical values are not tested and are not guaranteed on shipped production material.

Note 6: Limits are 100% production tested at 25°C. Limits over the operating temperature range are guaranteed through correlations using statistical quality control (SQC) method.

Note 7: Positive current corresponds to current flowing into the device.

Note 8: Slew rate is the average of the rising and falling slew rates.

Note 9: The part is not short circuit protected and is not recommended for operation with heavy resistive loads.

Connection Diagrams

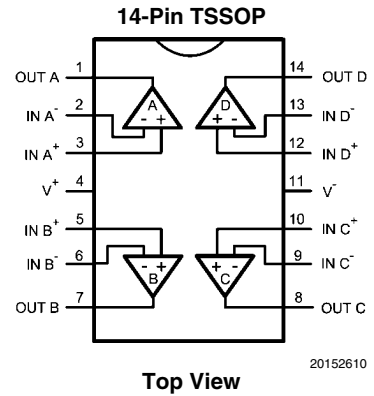
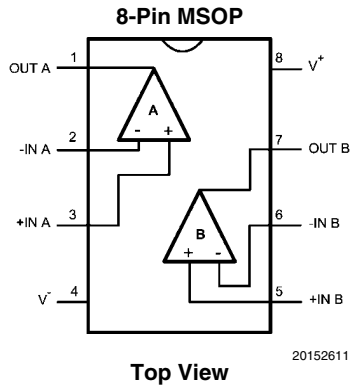
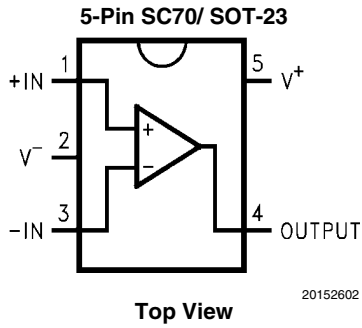

Ordering Information

Package	Part Number	Package Marking	Transport Media	NSC Drawing
5-Pin SC70	LMV551MG	A94	1k Units Tape and Reel	MAA05A
	LMV551MGX		3k Units Tape and Reel	
5-Pin SOT-23	LMV551MF	AF3A	1k Units Tape and Reel	MF05A
	LMV551MFX		3k Units Tape and Reel	
8-Pin MSOP	LMV552MM	AH3A	1k Units Tape and Reel	MUA08A
	LMV552MMX		3.5k Units Tape and Reel	
14-Pin TSSOP	LMV554MT	LMV554MT	94 Units/Rail	MTC14
	LMV554MTX		2.5k Units Tape and Reel	

Typical Performance Characteristics

Open Loop Gain and Phase with Capacitive Load

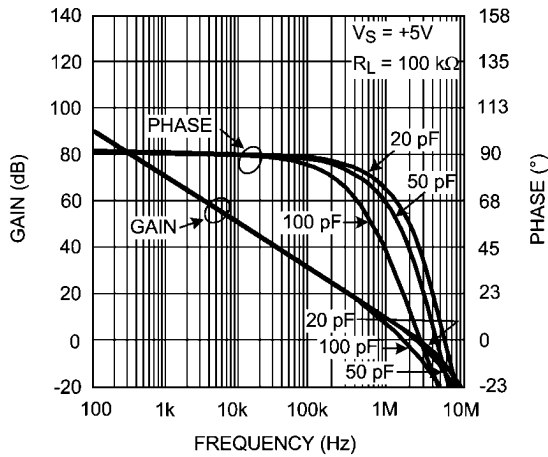

20152614

Open Loop Gain and Phase with Resistive Load

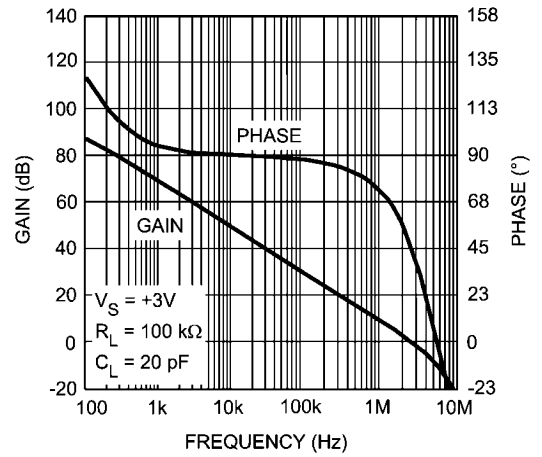

20152615

Open Loop Gain and Phase with Resistive Load

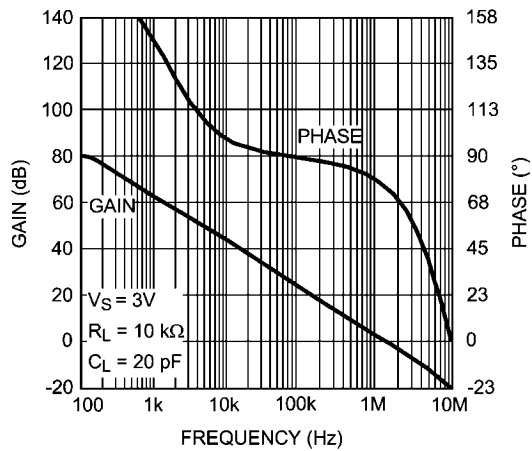

20152616

Open Loop Gain and Phase with Resistive Load

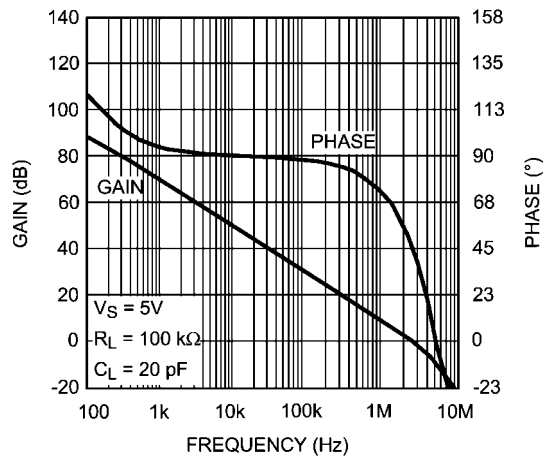

20152617

Open Loop Gain and Phase with Resistive Load

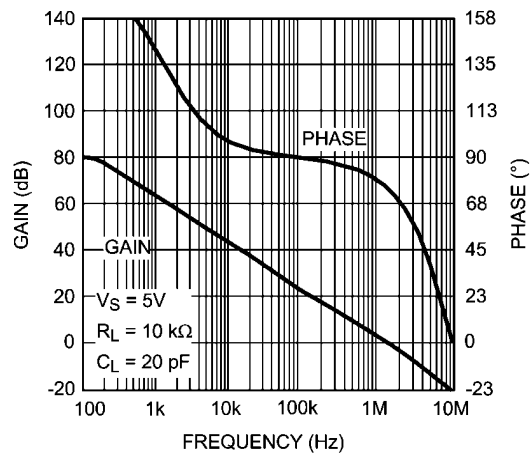

20152618

Slew Rate vs. Supply voltage

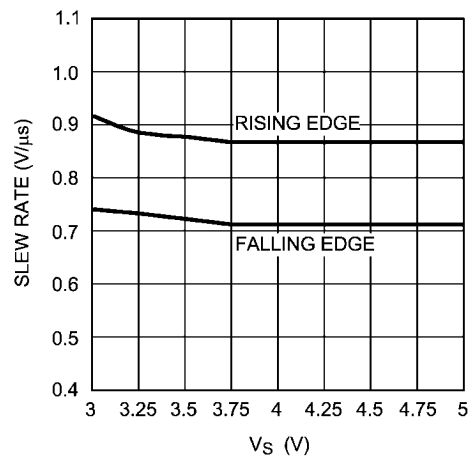

20152619

Small Signal Transient Response

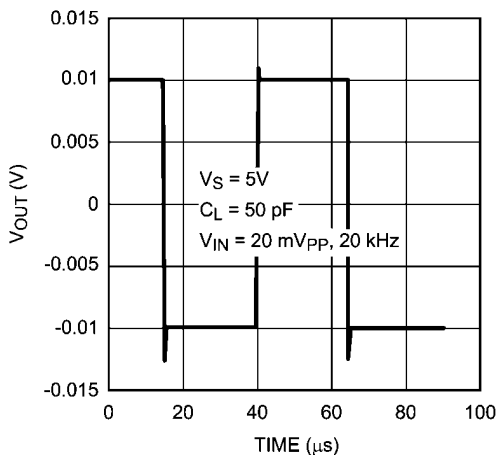

20152620

Large Signal Transient Response

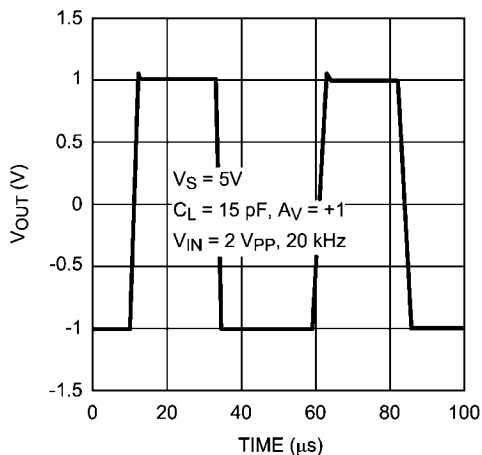

20152621

Small Signal Transient Response

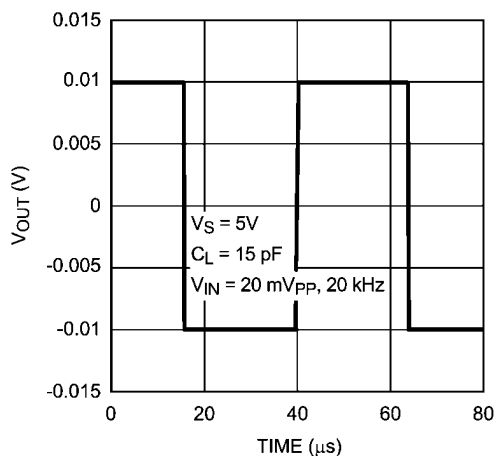

20152622

Input Referred Noise vs. Frequency

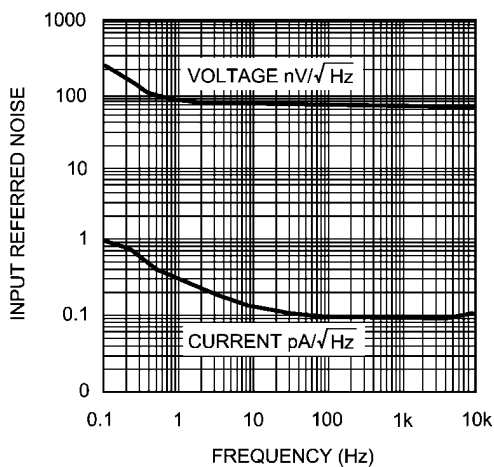

20152623

THD+N vs. Amplitude @ 3V

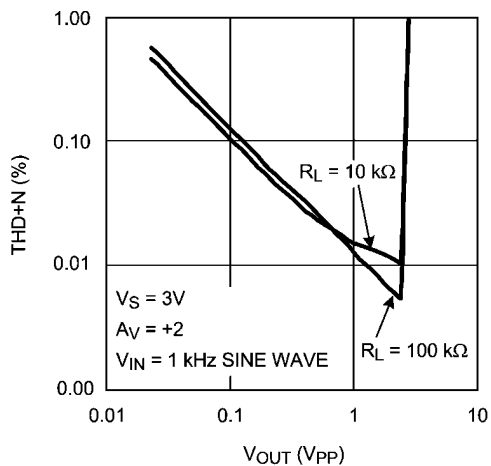

20152624

THD+N vs. Amplitude @ 5V

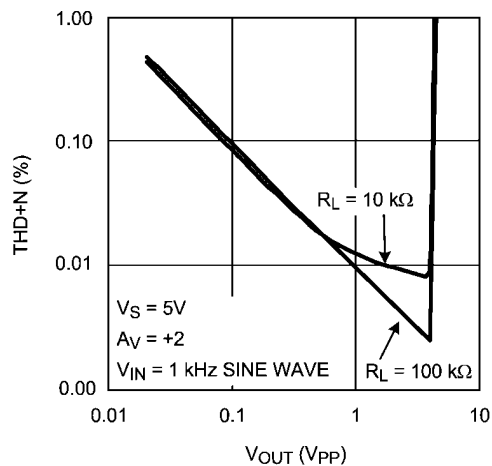

20152625

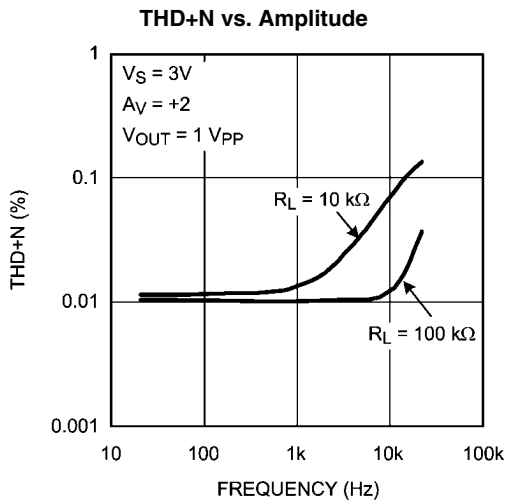

20152626

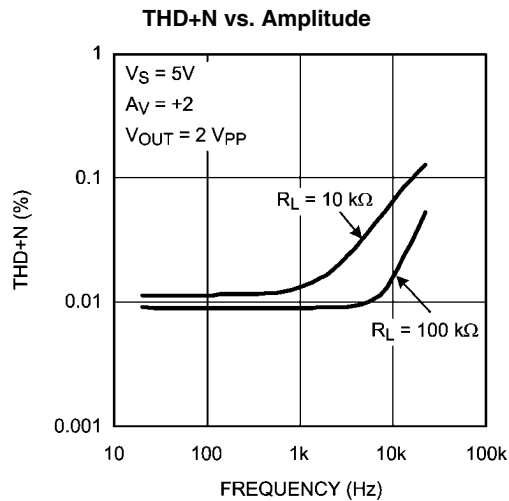

20152627

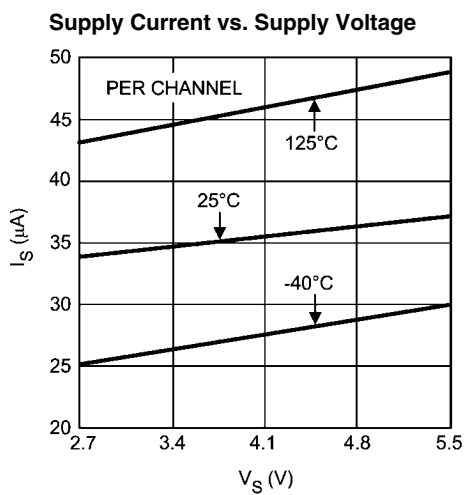

20152628

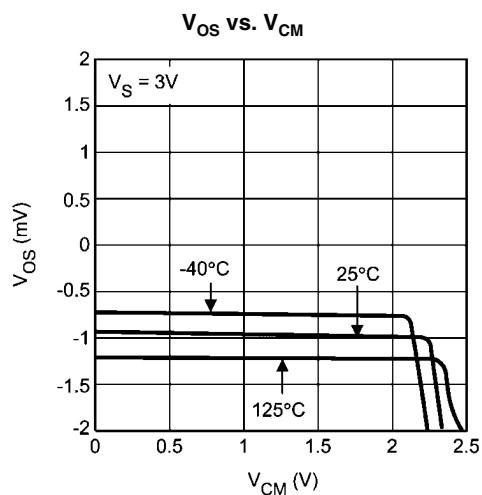

20152629

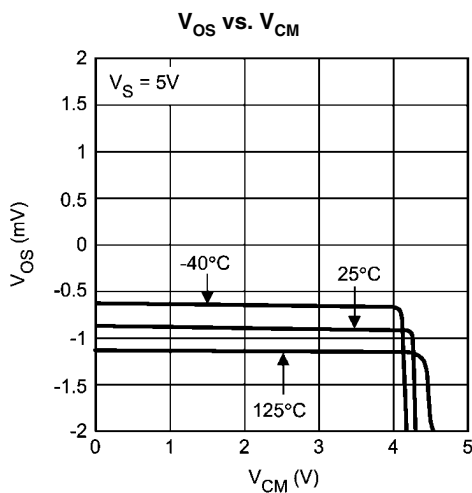

20152630

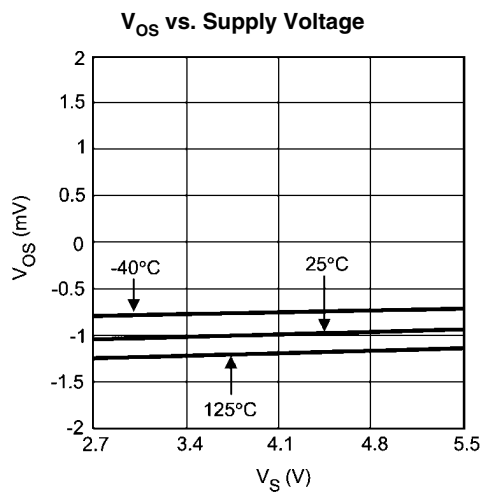

20152631

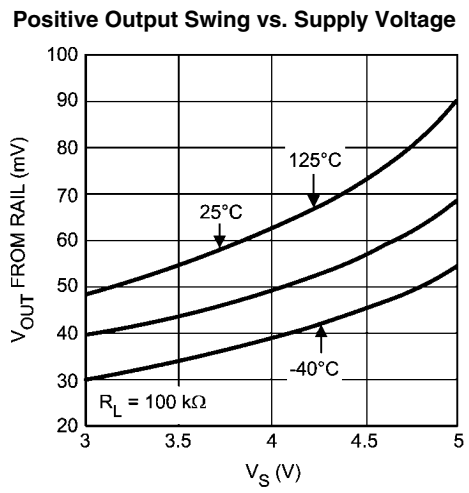
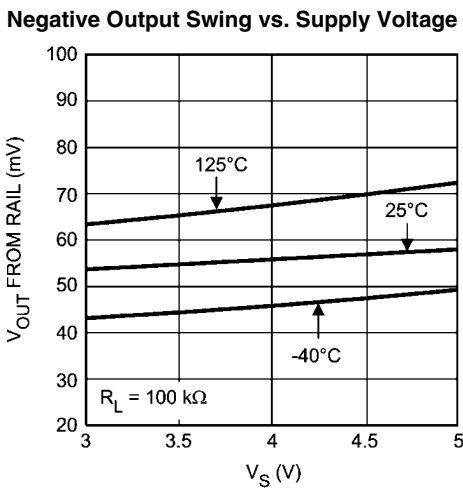
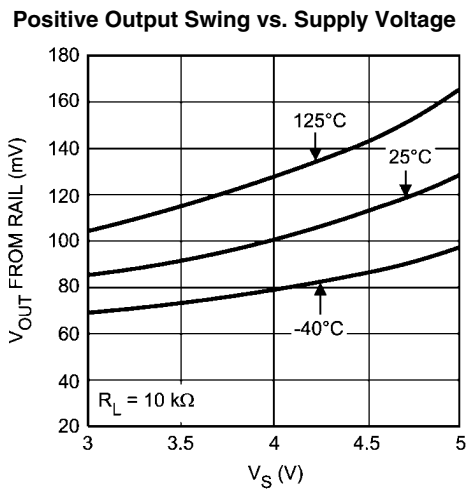
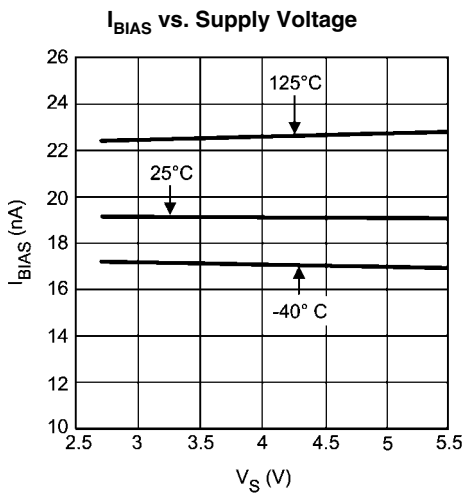
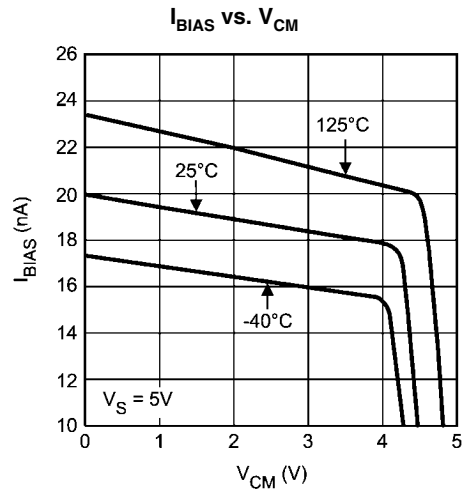
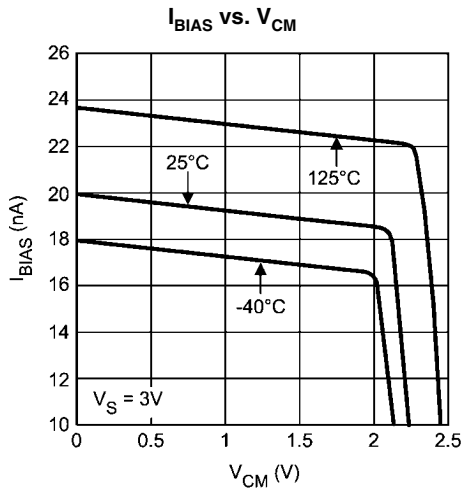

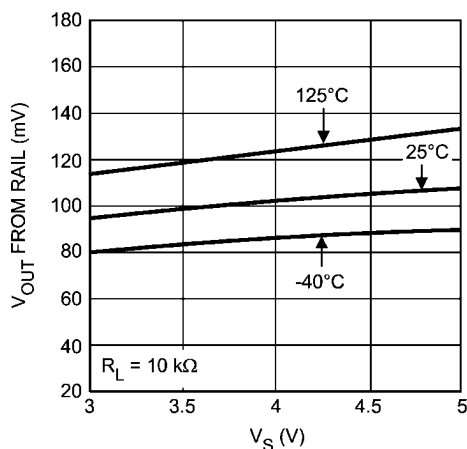
Negative Output Swing vs. Supply Voltage

20152638

Applications Information

ADVANTAGES OF THE LMV551/LMV552/LMV554

Low Voltage and Low Power Operation

The LMV551/LMV552/LMV554 have performance guaranteed at supply voltages of 3V and 5V and are guaranteed to be operational at all supply voltages between 2.7V and 5.5V. For this supply voltage range, the LMV551/LMV552/LMV554 draw the extremely low supply current of less than 37 μ A per amp.

Wide Bandwidth

The bandwidth to power ratio of 3 MHz to 37 μ A per amplifier is one of the best bandwidth to power ratios ever achieved. This makes these devices ideal for low power signal processing applications such as portable media players and instrumentation.

Low Input Referred Noise

The LMV551/LMV552/LMV554 provide a flatband input referred voltage noise density of $70 \text{ nV}/\sqrt{\text{Hz}}$, which is significantly better than the noise performance expected from an ultra low power op amp. They also feature the exceptionally low 1/f noise corner frequency of 4 Hz. This noise specification makes the LMV551/LMV552/LMV554 ideal for low power applications such as PDAs and portable sensors.

Ground Sensing and Rail-to-Rail Output

The LMV551/LMV552/LMV554 each have a rail-to-rail output stage, which provides the maximum possible output dynamic range. This is especially important for applications requiring a large output swing. The input common mode range includes the negative supply rail which allows direct sensing at ground in a single supply operation.

Small Size

The small footprints of the LMV551/LMV552/LMV554 packages save space on printed circuit boards, and enable the design of smaller and more compact electronic products. Long traces between the signal source and the op amp make the signal path susceptible to noise. By using a physically smaller package, the amplifiers can be placed closer to the signal source, reducing noise pickup and enhancing signal integrity.

STABILITY OF OP AMP CIRCUITS

Stability and Capacitive Loading

As seen in the Phase Margin vs. Capacitive Load graph, the phase margin reduces significantly for C_L greater than 100 pF. This is because the op amp is designed to provide the maximum bandwidth possible for a low supply current. Stabilizing them for higher capacitive loads would have required either a drastic increase in supply current, or a large internal compensation capacitance, which would have reduced the bandwidth of the op amp. Hence, if the LMV551/LMV552/LMV554 are to be used for driving higher capacitive loads, they will have to be externally compensated.

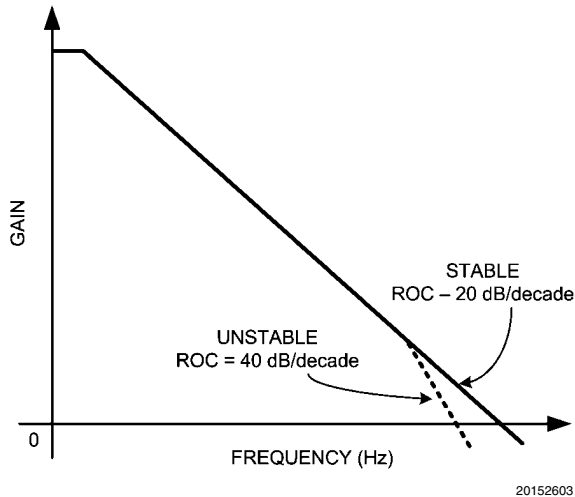

FIGURE 1. Gain vs. Frequency for an Op Amp

An op amp, ideally, has a dominant pole close to DC, which causes its gain to decay at the rate of 20 dB/decade with respect to frequency. If this rate of decay, also known as the rate of closure (ROC), remains the same until the op amp’s unity gain bandwidth, the op amp is stable. If, however, a large capacitance is added to the output of the op amp, it combines with the output impedance of the op amp to create another pole in its frequency response before its unity gain frequency (Figure 1). This increases the ROC to 40 dB/decade and causes instability.

In such a case a number of techniques can be used to restore stability to the circuit. The idea behind all these schemes is to modify the frequency response such that it can be restored to an ROC of 20 dB/decade, which ensures stability.

In the Loop Compensation

Figure 2 illustrates a compensation technique, known as ‘in the loop’ compensation, that employs an RC feedback circuit within the feedback loop to stabilize a non-inverting amplifier configuration. A small series resistance, R_S , is used to isolate the amplifier output from the load capacitance, C_L , and a small capacitance, C_F , is inserted across the feedback resistor to bypass C_L at higher frequencies.

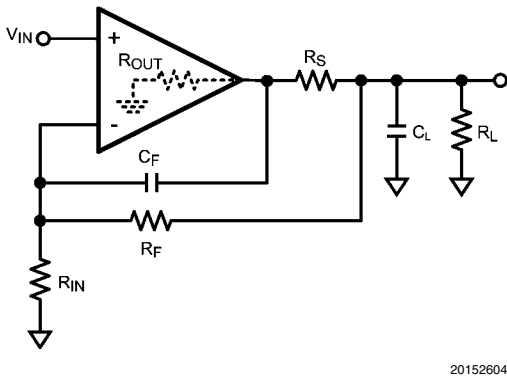

FIGURE 2. In the Loop Compensation

The values for R_S and C_F are decided by ensuring that the zero attributed to C_F lies at the same frequency as the pole attributed to C_L . This ensures that the effect of the second pole on the transfer function is compensated for by the presence of the zero, and that the ROC is maintained at 20 dB/decade. For the circuit shown in Figure 2 the values of R_S and C_F are given by Equation 1. Values of R_S and C_F required for maintaining stability for different values of C_L , as well as the phase margins obtained, are shown in Table 1. R_F , R_{IN} , and R_L are to be 10 kΩ, while R_{OUT} is 340Ω.

$$R_S = \frac{R_{OUT}R_{IN}}{R_F}$$

$$C_F = \left(1 + \frac{1}{A_{CL}}\right) \left(\frac{R_F + 2R_{IN}}{R_F^2}\right) C_L R_{OUT} \tag{1}$$

TABLE 1.

C_L (pF)	R_S (Ω)	C_F (pF)	Phase Margin ($^\circ$)
50	340	8	47
100	340	15	42
150	340	22	40

Although this methodology provides circuit stability for any load capacitance, it does so at the price of bandwidth. The closed loop bandwidth of the circuit is now limited by R_F and C_F .

Compensation by External Resistor

In some applications it is essential to drive a capacitive load without sacrificing bandwidth. In such a case, in the loop compensation is not viable. A simpler scheme for compensation is shown in [Figure 3](#). A resistor, R_{ISO} , is placed in series between the load capacitance and the output. This introduces a zero in the circuit transfer function, which counteracts the effect of the pole formed by the load capacitance and ensures stability. The value of R_{ISO} to be used should be decided depending on the size of C_L and the level of performance desired. Values ranging from 5Ω to 50Ω are usually sufficient to ensure stability. A larger value of R_{ISO} will result in a system with less ringing and overshoot, but will also limit the output swing and the short circuit current of the circuit.

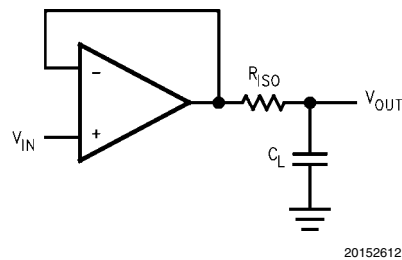

FIGURE 3. Compensation by Isolation Resistor

Typical Application

ACTIVE FILTERS

With a wide unity gain bandwidth of 3 MHz, low input referred noise density and a low power supply current, the LMV551/LMV552/LMV554 are well suited for low-power filtering applications. Active filter topologies, such as the Sallen-Key low pass filter shown in [Figure 4](#), are very versatile, and can be used to design a wide variety of filters (Chebyshev, Butterworth or Bessel). The Sallen-Key topology, in particular, can be used to attain a wide range of Q, by using positive feedback to reject the undesired frequency range.

In the circuit shown in [Figure 4](#), the two capacitors appear as open circuits at lower frequencies and the signal is simply buffered to the output. At high frequencies the capacitors appear as short circuits and the signal is shunted to ground by one of the capacitors before it can be amplified. Near the cut-off frequency, where the impedance of the capacitances is on the same order as R_G and R_F , positive feedback through the other capacitor allows the circuit to attain the desired Q.

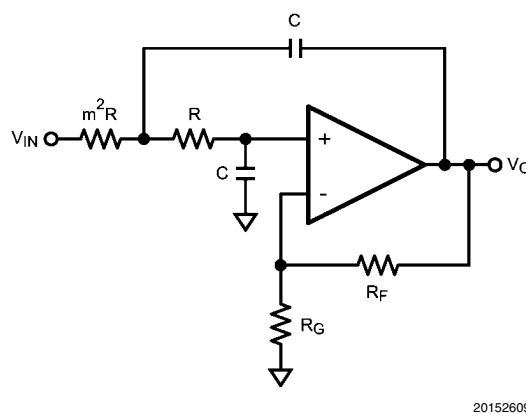
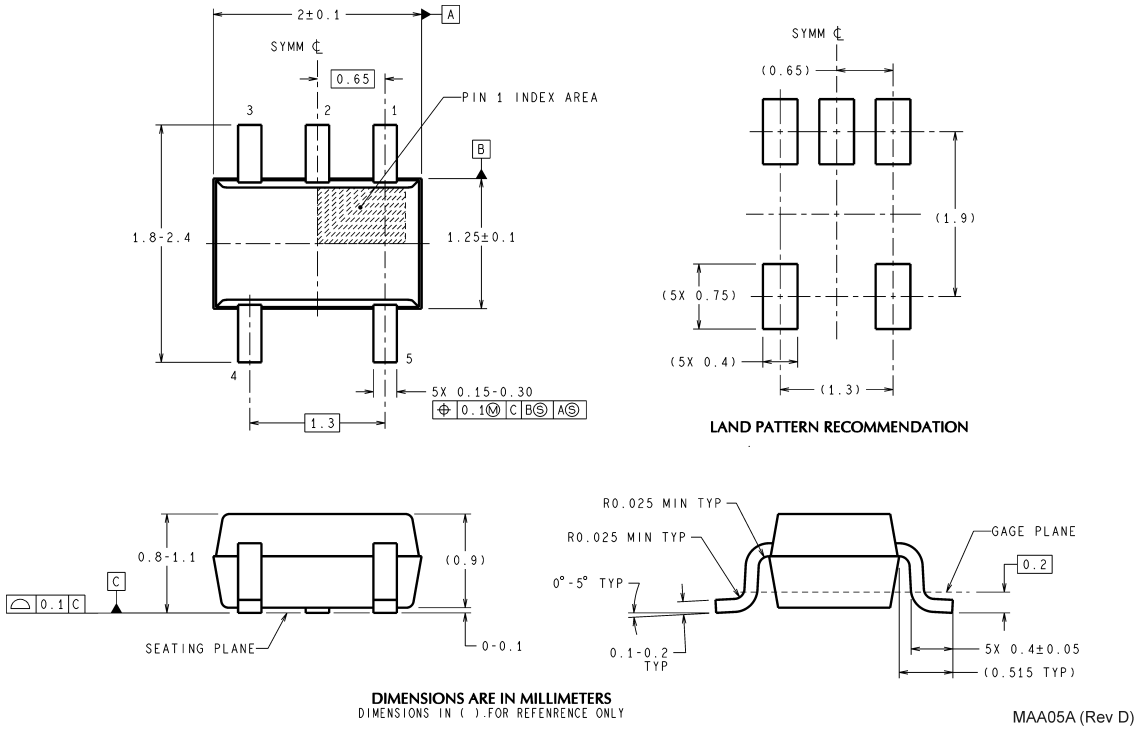
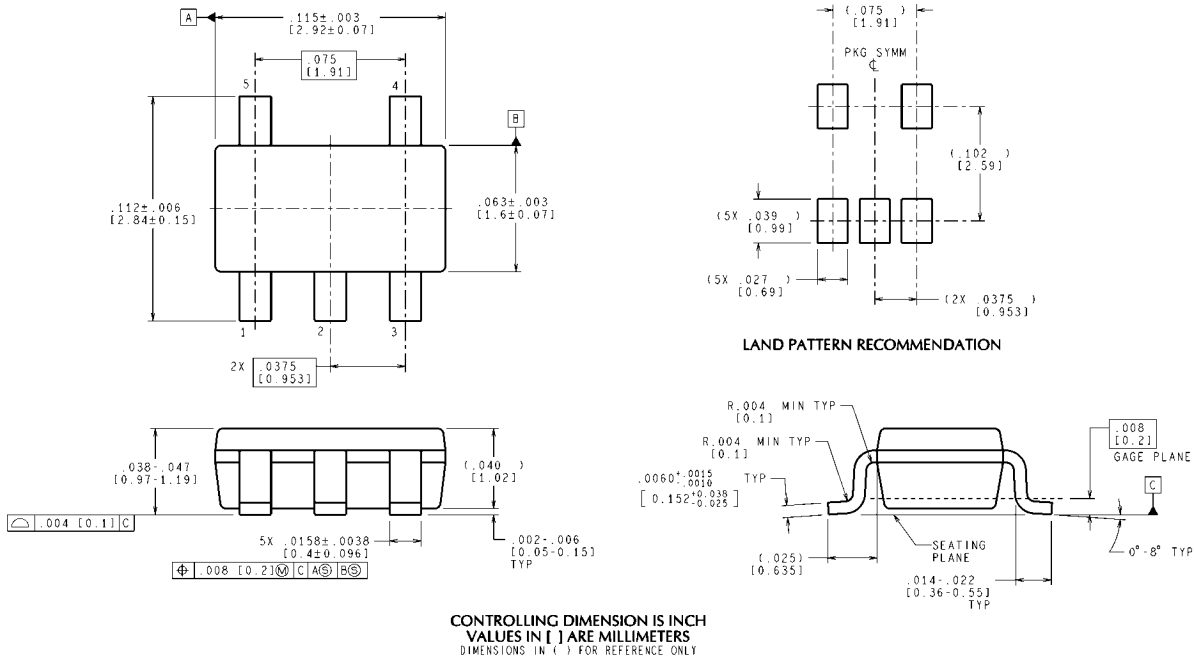

FIGURE 4. Sallen-Key Filter

Physical Dimensions inches (millimeters) unless otherwise noted



5-Pin SC70
NS Package Number MAA05A



5-Pin SOT-23
NS Package Number MF05A

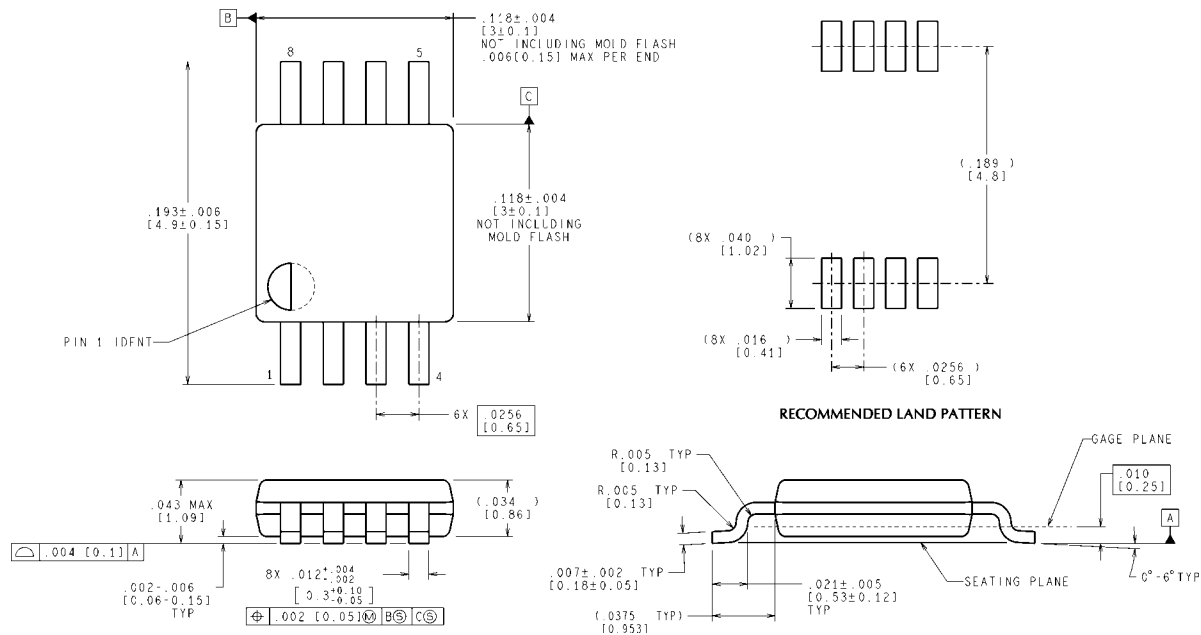

CONTROLLING DIMENSION IS INCH
VALUES IN [] ARE MILLIMETERS

8-Pin MSOP
NS Package Number MUA08A

MUA08A (Rev F)

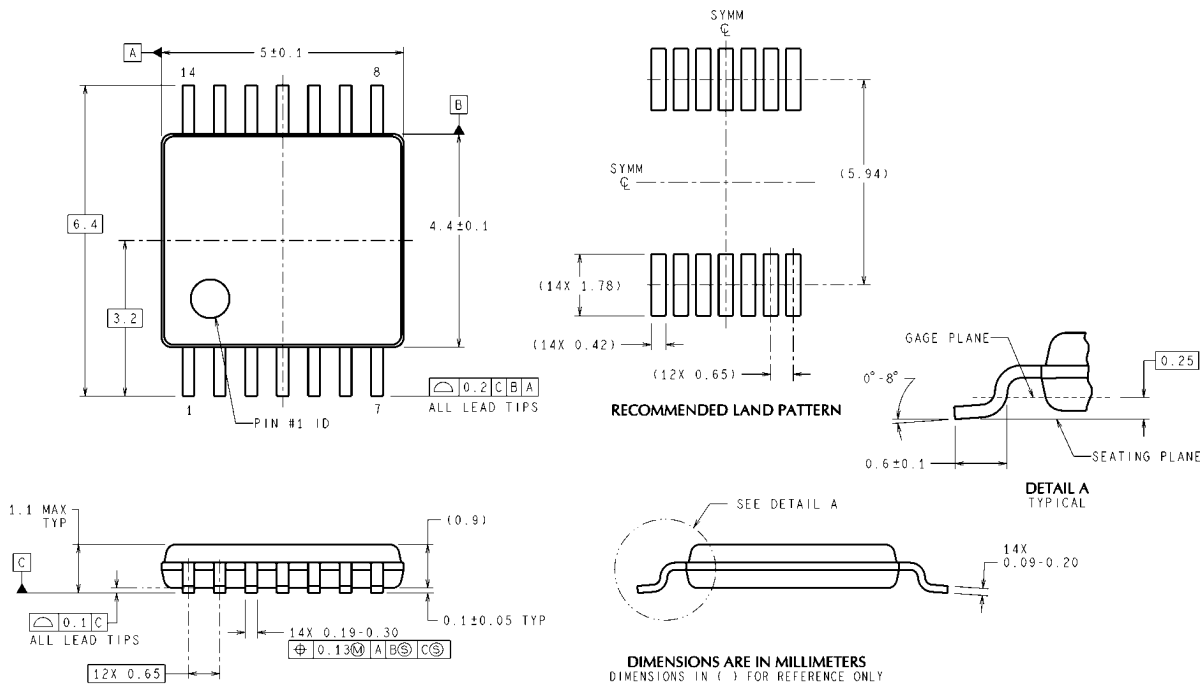

14-Pin TSSOP
NS Package Number MTC14

MTC14 (Rev D)

Notes

Notes

IMPORTANT NOTICE

Texas Instruments Incorporated and its subsidiaries (TI) reserve the right to make corrections, enhancements, improvements and other changes to its semiconductor products and services per JESD46C and to discontinue any product or service per JESD48B. Buyers should obtain the latest relevant information before placing orders and should verify that such information is current and complete. All semiconductor products (also referred to herein as "components") are sold subject to TI's terms and conditions of sale supplied at the time of order acknowledgment.

TI warrants performance of its components to the specifications applicable at the time of sale, in accordance with the warranty in TI's terms and conditions of sale of semiconductor products. Testing and other quality control techniques are used to the extent TI deems necessary to support this warranty. Except where mandated by applicable law, testing of all parameters of each component is not necessarily performed.

TI assumes no liability for applications assistance or the design of Buyers' products. Buyers are responsible for their products and applications using TI components. To minimize the risks associated with Buyers' products and applications, Buyers should provide adequate design and operating safeguards.

TI does not warrant or represent that any license, either express or implied, is granted under any patent right, copyright, mask work right, or other intellectual property right relating to any combination, machine, or process in which TI components or services are used. Information published by TI regarding third-party products or services does not constitute a license to use such products or services or a warranty or endorsement thereof. Use of such information may require a license from a third party under the patents or other intellectual property of the third party, or a license from TI under the patents or other intellectual property of TI.

Reproduction of significant portions of TI information in TI data books or data sheets is permissible only if reproduction is without alteration and is accompanied by all associated warranties, conditions, limitations, and notices. TI is not responsible or liable for such altered documentation. Information of third parties may be subject to additional restrictions.

Resale of TI components or services with statements different from or beyond the parameters stated by TI for that component or service voids all express and any implied warranties for the associated TI component or service and is an unfair and deceptive business practice. TI is not responsible or liable for any such statements.

Buyer acknowledges and agrees that it is solely responsible for compliance with all legal, regulatory and safety-related requirements concerning its products, and any use of TI components in its applications, notwithstanding any applications-related information or support that may be provided by TI. Buyer represents and agrees that it has all the necessary expertise to create and implement safeguards which anticipate dangerous consequences of failures, monitor failures and their consequences, lessen the likelihood of failures that might cause harm and take appropriate remedial actions. Buyer will fully indemnify TI and its representatives against any damages arising out of the use of any TI components in safety-critical applications.

In some cases, TI components may be promoted specifically to facilitate safety-related applications. With such components, TI's goal is to help enable customers to design and create their own end-product solutions that meet applicable functional safety standards and requirements. Nonetheless, such components are subject to these terms.

No TI components are authorized for use in FDA Class III (or similar life-critical medical equipment) unless authorized officers of the parties have executed a special agreement specifically governing such use.

Only those TI components which TI has specifically designated as military grade or "enhanced plastic" are designed and intended for use in military/aerospace applications or environments. Buyer acknowledges and agrees that any military or aerospace use of TI components which have **not** been so designated is solely at the Buyer's risk, and that Buyer is solely responsible for compliance with all legal and regulatory requirements in connection with such use.

TI has specifically designated certain components which meet ISO/TS16949 requirements, mainly for automotive use. Components which have not been so designated are neither designed nor intended for automotive use; and TI will not be responsible for any failure of such components to meet such requirements.

Products

Audio	www.ti.com/audio
Amplifiers	amplifier.ti.com
Data Converters	dataconverter.ti.com
DLP® Products	www.dlp.com
DSP	dsp.ti.com
Clocks and Timers	www.ti.com/clocks
Interface	interface.ti.com
Logic	logic.ti.com
Power Mgmt	power.ti.com
Microcontrollers	microcontroller.ti.com
RFID	www.ti-rfid.com
OMAP Mobile Processors	www.ti.com/omap
Wireless Connectivity	www.ti.com/wirelessconnectivity

Applications

Automotive and Transportation	www.ti.com/automotive
Communications and Telecom	www.ti.com/communications
Computers and Peripherals	www.ti.com/computers
Consumer Electronics	www.ti.com/consumer-apps
Energy and Lighting	www.ti.com/energy
Industrial	www.ti.com/industrial
Medical	www.ti.com/medical
Security	www.ti.com/security
Space, Avionics and Defense	www.ti.com/space-avionics-defense
Video and Imaging	www.ti.com/video

TI E2E Community e2e.ti.com