

**LM2657**

*LM2657 Dual Synchronous Buck Regulator Controller*

PDF.Support



Literature Number: SNVS342A

# LM2657

## Dual Synchronous Buck Regulator Controller

### General Description

The LM2657 is an adjustable 200kHz-500kHz dual channel voltage-mode controlled high-speed synchronous buck regulator controller ideally suited for high current applications. The LM2657 requires only N-channel FETs for both the upper and lower positions of each stage. It features line feedforward to improve the response to input transients. At very light loads, the user can choose between the high-efficiency Pulse-skip mode or the constant frequency Forced-PWM mode. Lossless current limiting without the use of external sense resistors is made possible by sensing the voltage drop across the bottom FET. A unique adaptive duty cycle clamping technique is incorporated to significantly reduce peak currents under abnormal load conditions. The two independently programmable outputs switch 180° out of phase (interleaved switching) reducing the input capacitor and filter requirements. The input voltage range is 4.5V to 28V while the output voltages are adjustable down to 0.6V. Standard supervisory and control features include Soft-start, Power Good, output Under-voltage and Over-voltage protection, Under-voltage Lockout, and chip Enable.

### Features

- Input voltage range from 4.5V to 28V
- Synchronous dual-channel interleaved switching
- Forced-PWM or Pulse-skip modes
- Lossless bottom-side FET current sensing
- Adaptive duty cycle clamp
- High current N-channel FET drivers
- Low shutdown supply current
- Reference voltage accurate to within  $\pm 1.5\%$
- Output voltage adjustable down to 0.6V
- Power Good flag and Chip Enable
- Under-voltage lockout
- Over-voltage/Under-voltage protection
- Soft-start
- Switching frequency adjustable 200kHz-500kHz
- TSSOP-28 package

### Applications

- Low Output Voltage High-Efficiency Buck Regulators

### Typical Application (Channel 2 in parenthesis)

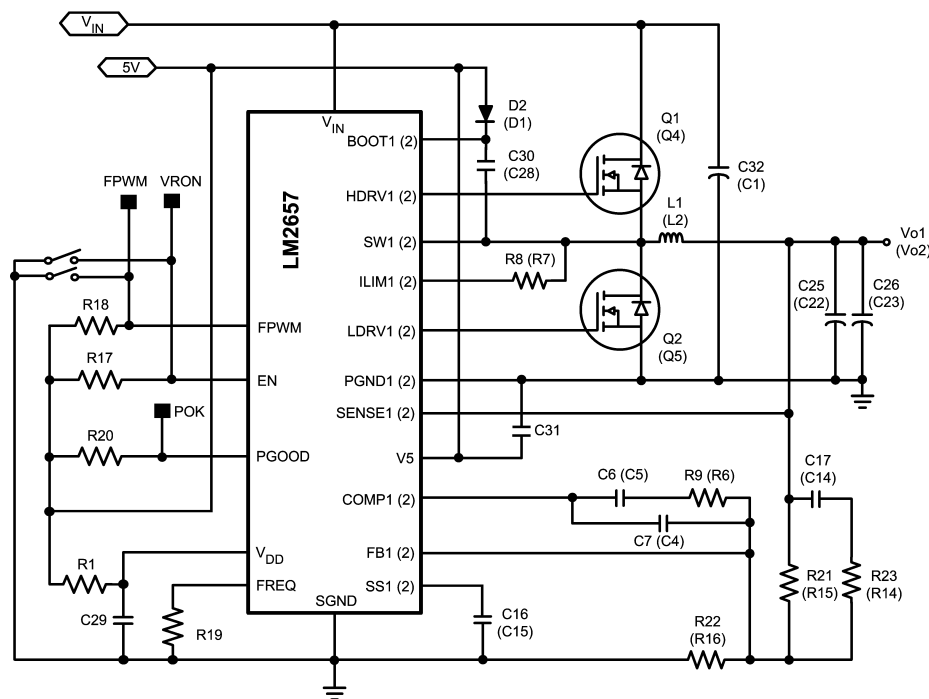

20134704

## Typical Application (Channel 2 in parenthesis) (Continued)

### Connection Diagram

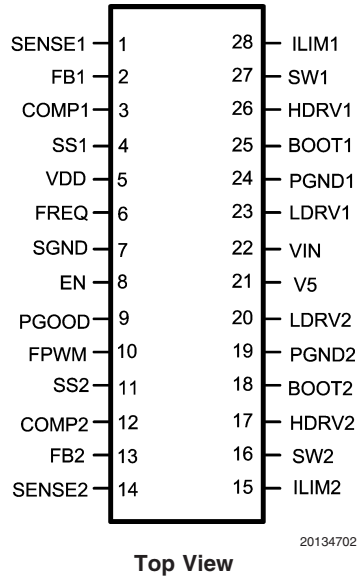

### Ordering Information

Order Number	Package Drawing	Supplied As
LM2657MTC	MTC28	48 Units/Rail
LM2657MTCX	MTC28	2500 Units/13" Reel

### Pin Description

**Pin 1, SENSE1:** Output voltage sense pin for Channel 1. It is tied directly to the output rail. The SENSE pin voltage is used by the IC, together with the VIN voltage (Pin 22) to calculate the CCM (continuous conduction mode) duty cycle. This is used by the IC to set the minimum duty cycle in the SKIP mode to 85% of the CCM value. It is also used to set the adaptive duty cycle clamp (see Pin 3).

**Pin 2, FB1:** Feedback pin for Channel 1. This is the inverting input of the channel's error amplifier. The voltage on this pin under regulation is nominally at 0.6V. A 'Power Good window' on this pin determines if the output voltage is within regulation limits ( $\pm 13\%$ ). If the voltage (on either channel) falls outside this window for more than 7 $\mu$ s, 'Power Not Good' is signaled on the PGOOD pin (Pin 9). Additionally, if the FB voltage is above the upper limit, an over-voltage fault condition occurs which turns on the low-side FET. The part will resume normal operation on the next high side cycle in which no fault is detected. When single channel operation is desired (one channel is used, the other is disabled), the feedback pins of both channels must be connected together, near the IC. All other pins specific to the unused channel should be left floating (not connected to each other, either).

**Pin 3, COMP1:** Compensation pin for Channel 1. This is the output of the error amplifier. The voltage level on this pin is compared with an internally generated ramp signal to set the duty cycle for normal regulation. Since the Feedback pin is the inverting input of the same error amplifier, the appropriate control loop compensation components are placed between this pin and the Feedback pin. The COMP pin is internally pulled low during Soft-start to limit the duty cycle. Once Soft-start is completed, the voltage on this pin can take up the value required to maintain output regulation. Note that

an internal voltage clamp does not allow the pin to go much higher than the steady-state requirement. This forms the 'adaptive duty cycle clamp' circuit, which serves to limit the maximum allowable duty cycle and peak currents under sudden overloads. Also note that this clamp has been designed with enough 'headroom' to permit an adequate response to step loads within normal operating range.

**Pin 4, SS1:** Channel 1 Soft-start pin. A Soft-start capacitor is placed between this pin and ground. A typical capacitance of 0.1 $\mu$ F is recommended. During startup using chip Enable/power-up, soft-start is reset by connecting an internal 1.8 k $\Omega$  resistor between this pin and ground ( $R_{SS\_DCHG}$ , see Electrical Characteristics table). It discharges any remaining charge on the Soft-start capacitors to ensure that the voltage on both Soft-start pins is below 100mV. Reset having thus been obtained, an 11 $\mu$ A current source at this pin charges up the Soft-start capacitor. The voltage on this pin controls the maximum duty cycle, and this produces a gradual ramp-up of the output voltage, thereby preventing large inrush currents into the output capacitors. The voltage on this pin finally clamps close to 5V. During current limit,  $V_{DD}$  UVLO, or  $V_{IN}$  UVLO this pin is connected to an internal 115 $\mu$ A current sink whenever a current limit event is in progress. This sink current quickly discharges the Soft-start capacitor and forces the duty cycle low to protect the power components.

**Pin 5, VDD:** 5V supply rail for the control and logic sections of both channels. For normal operation to start, the voltage on this pin must be brought above 4.5V. Subsequently, the voltage on this pin (including any ripple component) should not be allowed to fall below 4V for a duration longer than 7 $\mu$ s. Since this pin is also the supply rail for the internal control sections, it should be well-decoupled particularly at high frequencies. A minimum 0.1 $\mu$ F-0.47 $\mu$ F (ceramic) capacitor should be placed on the component side very close to the IC

## Pin Description (Continued)

with no intervening vias between this capacitor and the  $V_{DD}/SGND$  pins. If the voltage on Pin 5 falls below the lower UVLO threshold, the upper and lower FETs are both turned OFF. 'Power Not Good' is also signaled immediately (on Pin 9.) Normal operation will resume once the fault condition has cleared. Additionally if the voltage on this pin falls below the minimum voltage required for logic operation (about 1.8V typ) the part will shutdown identically to enable (see pin 8) being pulled low.

**Pin 6, FREQ:** Frequency adjust pin. The switching frequency (for both channels) is set by a resistor connected between this pin and ground. A value of 22.1k $\Omega$  sets the frequency to 300kHz (nominal). If the resistance is increased, the switching frequency falls. An approximate relationship is that for every 7.3k $\Omega$  increase (or decrease) in the value of the frequency adjust resistance, the time period (1/f) increases (or decreases) by about 1 $\mu$ s.

**Pin 7, SGND:** Signal Ground pin. This is the lower rail for the control and logic sections of both channels. SGND should be connected on the PCB to the system ground, which in turn is connected to PGND1 and PGND2. The layout is important and the recommendations in the section *Layout Guidelines* should be followed.

**Pin 8, EN:** IC Enable pin. When EN is taken high, both channels are enabled by means of a Soft-start power-up sequence (see Pin 4). When EN is brought low, 'Power Not Good' is signaled within 100ns. The Soft-start capacitor is then discharged by an internal 1.8k $\Omega$  resistor ( $R_{SS\_DCHG}$ , see Electrical Characteristics table) to ground.

**Pin 9, PGOOD:** Power Good output pin. An open-Drain logic output that is pulled high with an external pull-up resistor, indicating that both output voltages are within a pre-defined 'Power Good' window,  $V_{IN}$  and  $V_{DD}$  are within required operating range, and enable is high. Outside this window, this pin is internally pulled low ('Power Not Good' signaled) provided the output error lasts for more than 7 $\mu$ s. The pin also goes low within 100ns of the Enable pin being taken low, or  $V_{DD}$  going below UVLO, or  $V_{IN}$  going below UVLO irrespective of the output voltage level. Regulation on both channels must be achieved first before fault monitoring becomes active (i.e. PGOOD must have been high prior to occurrence of the fault condition for a fault to be asserted). For correct signaling on this pin under single-channel operation, see description of Pin 2.

**Pin 10, FPWM:** Logic input for selecting either the Forced PWM ('FPWM') Mode or Pulse-skip Mode ('SKIP') for both channels (together). When the pin is driven high, the IC operates in the FPWM mode, and when pulled low or left floating, the SKIP mode is enabled. In FPWM mode, the lower FET of a given channel is always ON whenever the upper FET is OFF (except for a narrow shoot-through protection deadband). This leads to continuous conduction mode of operation, which has a fixed frequency and (almost) fixed duty cycle down to very light loads. But this does reduce efficiency at light loads. The alternative is the SKIP mode, where the lower FET remains ON only till the voltage on the Switch pin (see Pin 27 or Pin 16) goes above -2.2mV (typical). So for example, for a 21m $\Omega$  FET, this translates to a current threshold of  $2.2/21 = 0.1A$ . Therefore if the (instantaneous) inductor current falls below this value, the lower FET will turn OFF every cycle at this point (when operated in SKIP mode). This threshold is set by the 'Zero-cross Comparator' in the Block Diagram. Note that if the inductor current waveform is high enough to cause the SW pin to be

always below this 'zero-cross threshold' (see Electrical Characteristics table), there will be no observable difference between FPWM and SKIP mode settings (in steady-state). SKIP mode, when it occurs, is clearly a discontinuous mode of operation. However, in conventional discontinuous mode, the duty cycle keeps falling (towards zero) as the load decreases. But the LM2657 does not 'allow' the duty cycle to fall by more than 15% of its original value (at the CCM-DCM boundary). This leads to pulse-skipping, and so the average frequency decreases as the load decreases. This mode of operation improves efficiency at light loads, but the frequency is effectively no longer a constant. Note that a minimum preload of 0.1mA should be maintained on the output of each channel to ensure regulation in SKIP mode. The resistive divider from output to ground used to set the output voltage could be designed to serve as this preload.

**Pin 11, SS2:** Soft-start pin for Channel 2. See Pin 4.

**Pin 12, COMP2:** Compensation pin for Channel 2. See Pin 3.

**Pin 13, FB2:** Feedback pin for Channel 2. See Pin 2.

**Pin 14, SENSE2:** Output voltage sense pin for Channel 2. See Pin 1.

**Pin 15, ILIM2:** Channel 2 Current Limit pin. When the bottom FET is ON, a 62 $\mu$ A (typical) current flows out of this pin into an external current limit setting resistor connected to the drain of the lower FET. This is a current source so the drop across this resistor tries to push the voltage on this pin to a more positive value. However, the drain of the lower FET, which is connected to the other side of the same resistor, is trying to go more negative as the load current increases. Therefore at some value of current, the voltage on this pin will cross zero and start to go negative. This is the current limiting condition and it is detected by the 'Current Limit Comparator' seen in the Block Diagram. When a current limit condition has been detected, the next ON-pulse of the upper FET will be omitted. The lower FET will again be monitored to determine if the current has fallen below the threshold. If it has, the next ON-pulse will be permitted. If not, the upper FET will stay OFF, and remain so for several cycles if necessary, until the current returns to normal. Eventually, if the overcurrent condition persists and the upper FET has not been turned ON, the output will start to fall eventually triggering "Power not Good".

**Pin 16, SW2:** The Switching node of the buck regulator of Channel 2. Also serves as the lower rail of the floating driver of the upper FET.

**Pin 17, HDRV2:** Gate drive pin for the upper FET of Channel 2 (High-side drive). The top gate driver is interlocked with the bottom gate driver to prevent shoot-through/cross-conduction.

**Pin 18, BOOT2:** Bootstrap pin for Channel 2. This is the upper supply rail for the floating driver of the upper FET. It is bootstrapped by means of a ceramic capacitor connected to the channel Switching node. This capacitor is charged up by the IC to a value of about 5V as derived from the V5 pin (Pin 21).

**Pin 19, PGND2:** Power Ground pin of Channel 2. This is the return path for the bottom FET gate drive. Both the PGND's are to be connected on the PCB to the system ground and also to the Signal ground (Pin 7) in accordance with the recommended Layout Guidelines .

**Pin 20, LDRV2:** Gate drive pin for the Channel 2 bottom FET (Low-side drive). The bottom gate driver is interlocked with the top gate driver to prevent shoot-through/cross-conduction.

## Pin Description (Continued)

**Pin 21, V5:** Upper rail of the lower FET drivers of both channels. Also used to charge up the bootstrap capacitors of the upper FET drivers. This is connected to an external 5V supply. The 5V rail may be the same as the rail used to provide power to the VDD pin (Pin 5). If these rails are connected, the VDD pin must be well-decoupled so that it does not interact with the V5 pin. A minimum 0.1 $\mu$ F (ceramic) capacitor should be placed on the component side very close to the IC with no intervening vias between this capacitor and the V5/PGND pins.

**Pin 22, VIN:** The input that powers both the buck regulator channels. It also is used by the internal ramp generator to implement the line 'feedforward' feature. The VIN pin is also

used with the SENSE pin voltage to predict the CCM (continuous conduction mode) duty cycle and to thereby set the minimum allowed DCM duty cycle to 85% of the CCM value (in SKIP mode, see Pin 10). This is a high input impedance pin, drawing only about 115 $\mu$ A from the input rail. A fault condition will occur if this voltage drops below its UVLO threshold.

**Pin 23, LDRV1:** LDRV pin of Channel 1. See Pin 20.

**Pin 24, PGND1:** PGND pin for Channel 1. See Pin 19.

**Pin 25, BOOT1:** Boot pin of Channel 1. See Pin 18.

**Pin 26, HDRV1:** HDRV pin of Channel 1. See Pin 17.

**Pin 27, SW1:** SW pin of Channel 1. See Pin 16.

**Pin 28, ILIM1:** Channel 1 Current Limit pin. See Pin 15.

## Absolute Maximum Ratings (Note 1)

If Military/Aerospace specified devices are required, please contact the National Semiconductor Sales Office/Distributors for availability and specifications.

Voltages from the indicated pins to GND unless otherwise indicated (Note 2):

VIN	-0.3V to 30V
V5	-0.3V to 7V
VDD	-0.3V to 7V
BOOT1, BOOT2	-0.3V to 36V
BOOT1 to SW1, BOOT2 to SW2	-0.3V to 7V
SW1, SW2	-0.3V to 30V
ILIM1, ILIM2	-0.3V to 30V
SENSE1, SENSE2, FB1, FB2	-0.3V to 7V
PGOOD	-0.3V to 7V

EN	-0.3V to 7V
Junction Temperature	+150°C
ESD Rating (Note 3)	2kV
Ambient Storage Temperature Range	-65°C to +150°C
Soldering Dwell Time, Temperature	
Wave	4 sec, 260°C
Infrared	10 sec, 240°C
Vapor Phase	75 sec, 219°C

## Operating Ratings (Note 1)

VIN	4.5V to 28V
VDD, V5	4.5V to 5.5V
Junction Temperature	-40°C to +125°C

## Electrical Characteristics

Specifications with standard typeface are for  $T_J = 25^\circ\text{C}$ , and those with **boldface** apply over full

**Operating Junction Temperature** range.  $V_{DD} = V_5 = 5V$ ,  $V_{SGND} = V_{PGND} = 0V$ ,  $V_{IN} = 15V$ ,  $V_{EN} = 3V$ ,  $R_{FADJ} = 22.1k\Omega$  unless otherwise stated (Note 4). Datasheet min/max specification limits are guaranteed by design, test, or statistical analysis.

Symbol	Parameter	Conditions	Min	Typical (Note 5)	Max	Units
<b>Reference</b>						
$V_{FB}$	FB Pin Voltage at Regulation (either FB Pin)	$V_{DD} = 4.5V$ to $5.5V$ , $V_{IN} = 4.5V$ to $28V$	<b>591</b>	600	<b>609</b>	mV
$V_{FB\_LINE\ REG}$	$V_{FB}$ Line Regulation ( $\Delta V_{FB}$ )	$V_{DD} = 4.5V$ to $5.5V$ , $V_{IN} = 4.5V$ to $28V$		0.5		
$I_{FB}$	FB Pin Current (sourcing)	$V_{FB}$ at regulation		20	<b>100</b>	nA
<b>Chip Supply</b>						
$I_{Q\_VIN}$	VIN Quiescent Current	$V_{FB1} = V_{FB2} = 0.7V$		100	<b>200</b>	$\mu\text{A}$
$I_{SD\_VIN}$	VIN Shutdown Current	$V_{EN} = 0V$		0	<b>5</b>	$\mu\text{A}$
$I_{Q\_VDD}$	VDD Quiescent Current	$V_{FB1} = V_{FB2} = 0.7V$		2.5	<b>4</b>	mA
$I_{SD\_VDD}$	VDD Shutdown Current	$V_{EN} = 0V$		6	<b>15</b>	$\mu\text{A}$
$I_{Q\_V5}$	V5 Normal Operating Current	$V_{FB1} = V_{FB2} = 0.7V$		0.3	<b>0.5</b>	mA
		$V_{FB1} = V_{FB2} = 0.5V$		1	<b>1.5</b>	
$I_{SD\_V5}$	V5 Shutdown Current	$V_{EN} = 0V$		0	<b>5</b>	$\mu\text{A}$
$I_{Q\_BOOT}$	BOOT Quiescent Current	$V_{FB1} = V_{FB2} = 0.7V$		2	<b>5</b>	$\mu\text{A}$
		$V_{FB1} = V_{FB2} = 0.5V$		300	<b>500</b>	
$I_{SD\_BOOT}$	BOOT Shutdown Current	$V_{EN} = 0V$		1	<b>5</b>	$\mu\text{A}$
$V_{DD\_UVLO}$	VDD UVLO Threshold	VDD rising up to $V_{UVLO}$	<b>3.9</b>	4.2	<b>4.5</b>	V
	VDD UVLO Hysteresis	VDD = V5 falling from $V_{UVLO}$	<b>0.5</b>	0.7	<b>0.9</b>	V
$V_{IN\_UVLO}$	VIN UVLO Threshold	VIN rising up to $V_{UVLO}$	<b>3.9</b>	4.2	<b>4.5</b>	V
	VIN UVLO Hysteresis	VIN falling from $V_{UVLO}$		0.1	<b>0.3</b>	V
<b>Logic</b>						
$I_{EN}$	EN Input Current	$V_{EN} = 0$ to $5V$		0		$\mu\text{A}$
$V_{EN\_HI}$	Minimum EN Input Logic High		<b>2</b>			V
$V_{EN\_LO}$	Maximum EN Input Logic Low				<b>0.8</b>	V
$R_{FPWM}$	FPWM Pull-down	$V_{FPWM} = 2V$	<b>100</b>	200	<b>1000</b>	k $\Omega$

## Electrical Characteristics (Continued)

Specifications with standard typeface are for  $T_J = 25^\circ\text{C}$ , and those with **boldface** apply over full

**Operating Junction Temperature** range.  $V_{DD} = V_5 = 5\text{V}$ ,  $V_{SGND} = V_{PGND} = 0\text{V}$ ,  $V_{IN} = 15\text{V}$ ,  $V_{EN} = 3\text{V}$ ,  $R_{FADJ} = 22.1\text{k}\Omega$  unless otherwise stated (Note 4). Datasheet min/max specification limits are guaranteed by design, test, or statistical analysis.

Symbol	Parameter	Conditions	Min	Typical (Note 5)	Max	Units
$V_{FPWM\_HI}$	Minimum FPWM Input Logic High		<b>2</b>			V
$V_{FPWM\_LO}$	Maximum FPWM Input Logic Low				<b>0.8</b>	V
<b>Power Good and OVP</b>						
$V_{PGOOD\_HI}$	Power Good Upper Threshold as a Percentage of Internal Reference	FB voltage rising above $V_{FB}$	<b>110</b>	113	<b>116</b>	%
$V_{PGOOD\_LOW}$	Power Good Lower Threshold as a Percentage of Internal Reference	FB voltage falling below $V_{FB}$	<b>84</b>	87	<b>90</b>	%
$HYS_{PGOOD}$	Power Good Hysteresis			7		%
$\Delta t_{PG\_OK}$	Power Good Delay	From both output voltages "good" to PGOOD assertion.	<b>10</b>	20	<b>30</b>	$\mu\text{s}$
$\Delta t_{PG\_NOK}$		From the first output voltage "bad" to PGOOD de-assertion	<b>4</b>	7	<b>10</b>	
$\Delta t_{SD}$		From Enable low to PGOOD low		0.03	<b>0.1</b>	
$V_{PGOOD\_SAT}$	PGOOD Saturation Voltage	PGOOD de-asserted (Power Not Good) and sinking 1.5mA		0.12	<b>0.4</b>	V
$I_{PGOOD\_LEAK}$	PGOOD Leakage Current	PGOOD = 5V and asserted		0	<b>1</b>	$\mu\text{A}$
<b>Soft-start</b>						
$I_{SS\_CHG}$	Soft-start Charging Current	$V_{SS} = 1\text{V}$	<b>8</b>	11	<b>14</b>	$\mu\text{A}$
$R_{SS\_DCHG}$	Soft-shutdown Resistance (SS pin to SGND, either channel)	$V_{EN} = 0\text{V}$ , $V_{SS} = 1\text{V}$		1800		$\Omega$
$I_{SS\_DCHG}$	Soft-start Discharge Current	In Current Limit	<b>80</b>	115	<b>160</b>	$\mu\text{A}$
$V_{SS\_RESET}$	Soft-start pin reset voltage (Note 6)	SS charged to 0.5V, EN low to high		100		mV
$V_{OS}$	SS to COMP Offset Voltage	$V_{SS} = 0.5\text{V}$ and $1\text{V}$ , $V_{FB1} = V_{FB2} = 0\text{V}$		600		mV
<b>Error Amplifier</b>						
GAIN	DC Gain			70		dB
$V_{SLEW}$	Voltage Slew Rate	COMP rising		4.45		V/ $\mu\text{s}$
		COMP falling		2.25		
BW	Unity Gain Bandwidth			6.5		MHz
$I_{COMP\_SOURCE}$	COMP Source Current	$V_{FB} = \text{lower COMP} = 0.5\text{V}$	<b>2</b>	5		mA
$I_{COMP\_SINK}$	COMP Sink Current	$V_{FB} = \text{higher than internal reference}$ COMP = 5V	<b>7</b>	14		mA
<b>Current Limit and Zero-Cross</b>						
$I_{ILIM}$	ILIM Pin Current (sourcing, either ILIM pin)	$V_{ILIM1} = V_{ILIM2} = 0\text{V}$	<b>46</b>	62	<b>76</b>	$\mu\text{A}$
$V_{ILIM\_TH}$	ILIM Threshold Voltage		<b>-10</b>	0	<b>10</b>	mV
$V_{SW\_ZERO}$	Zero-cross Threshold (SW Pin)	LDRV goes low		-2.2		mV



## Electrical Characteristics (Continued)

Specifications with standard typeface are for  $T_J = 25^\circ\text{C}$ , and those with **boldface** apply over full **Operating Junction Temperature** range.  $V_{DD} = V_5 = 5\text{V}$ ,  $V_{SGND} = V_{PGND} = 0\text{V}$ ,  $V_{IN} = 15\text{V}$ ,  $V_{EN} = 3\text{V}$ ,  $R_{FADJ} = 22.1\text{k}\Omega$  unless otherwise stated (Note 4). Datasheet min/max specification limits are guaranteed by design, test, or statistical analysis.

Symbol	Parameter	Conditions	Min	Typical (Note 5)	Max	Units
<b>Oscillator</b>						
$F_{OSC}$	PWM Frequency	$R_{FADJ} = 22.1\text{k}\Omega$	<b>255</b>	300	<b>345</b>	kHz
		$R_{FADJ} = 12.4\text{k}\Omega$		500		
		$R_{FADJ} = 30.9\text{k}\Omega$		200		
$V_{RAMP}$	PWM Ramp Peak-to-peak Amplitude	$V_{IN} = 4.5\text{V}$		0.48		V
		$V_{IN} = 15\text{V}$		1.6		
		$V_{IN} = 28\text{V}$		3.0		
$V_{VALLEY}$	PWM Ramp Valley			0.8		V
$\Delta_{FOSC\_VIN}$	Frequency Change with VIN	$V_{IN} = 4.5\text{V to } 28\text{V}$		$\pm 1$		%
$\Delta_{FOSC\_VDD}$	Frequency Change with VDD	$V_{DD} = 4.5\text{V to } 5.5\text{V}$		$\pm 2$		%
$\theta_{CH}$	Phase Shift Between Channels	Phase from HDRV1 to LDRV2	<b>165</b>	180	<b>195</b>	deg
$V_{FREQ\_VIN}$	FREQ Pin Voltage vs. VIN			0.107		V/V
<b>System</b>						
$t_{on-min}$	Minimum ON Time	$V_{FPWM} = 3\text{V}$		30		ns
$D_{MAX}$	Maximum Duty Cycle	$V_{IN} = 4.5\text{V}$	<b>60</b>	70		%
		$V_{IN} = 15\text{V}$	<b>40</b>	50		%
		$V_{IN} = 28\text{V}, V_{DD} = 4.5\text{V}$	<b>24</b>	30		%
<b>Gate Drivers</b>						
$R_{HDRV\_SOURCE}$	HDRV Source Impedance	HDRV Pin Current (sourcing) = 1.2A		7		$\Omega$
$R_{HDRV\_SINK}$	HDRV Sink Impedance	HDRV Pin Current (sinking) = 1A		2		$\Omega$
$R_{LDRV\_SOURCE}$	LDRV Source Impedance	LDRV Pin Current (sourcing) = 1.2A		7		$\Omega$
$R_{LDRV\_SINK}$	LDRV Sink Impedance	LDRV Pin Current (sinking) = 2A		1		$\Omega$
$t_{DEAD}$	Cross-conduction Protection Delay (deadtime)	HDRV Falling to LDRV Rising		40		ns
		LDRV Falling to HDRV Rising		70		

**Note 1:** Absolute maximum ratings indicate limits beyond which damage to the device may occur. Operating Ratings are conditions under which operation of the device is guaranteed. For guaranteed performance limits and associated test conditions, see the Electrical Characteristics table.

**Note 2:** PGND1, PGND2 and SGND are all electrically connected together on the PCB.

**Note 3:** ESD is applied by the human body model, which is a 100pF capacitor discharged through a 1.5 k $\Omega$  resistor into each pin.

**Note 4:**  $R_{FADJ}$  is the frequency adjust resistor between FREQ pin and SGND pin.

**Note 5:** Typical numbers are at  $25^\circ\text{C}$  and represent the most likely norm.

**Note 6:** If the LM2657 starts up with a pre-charged soft start capacitor, it will first discharge the capacitor to  $V_{SS\_RESET}$  and then begin the normal Soft-start process.



# Block Diagram

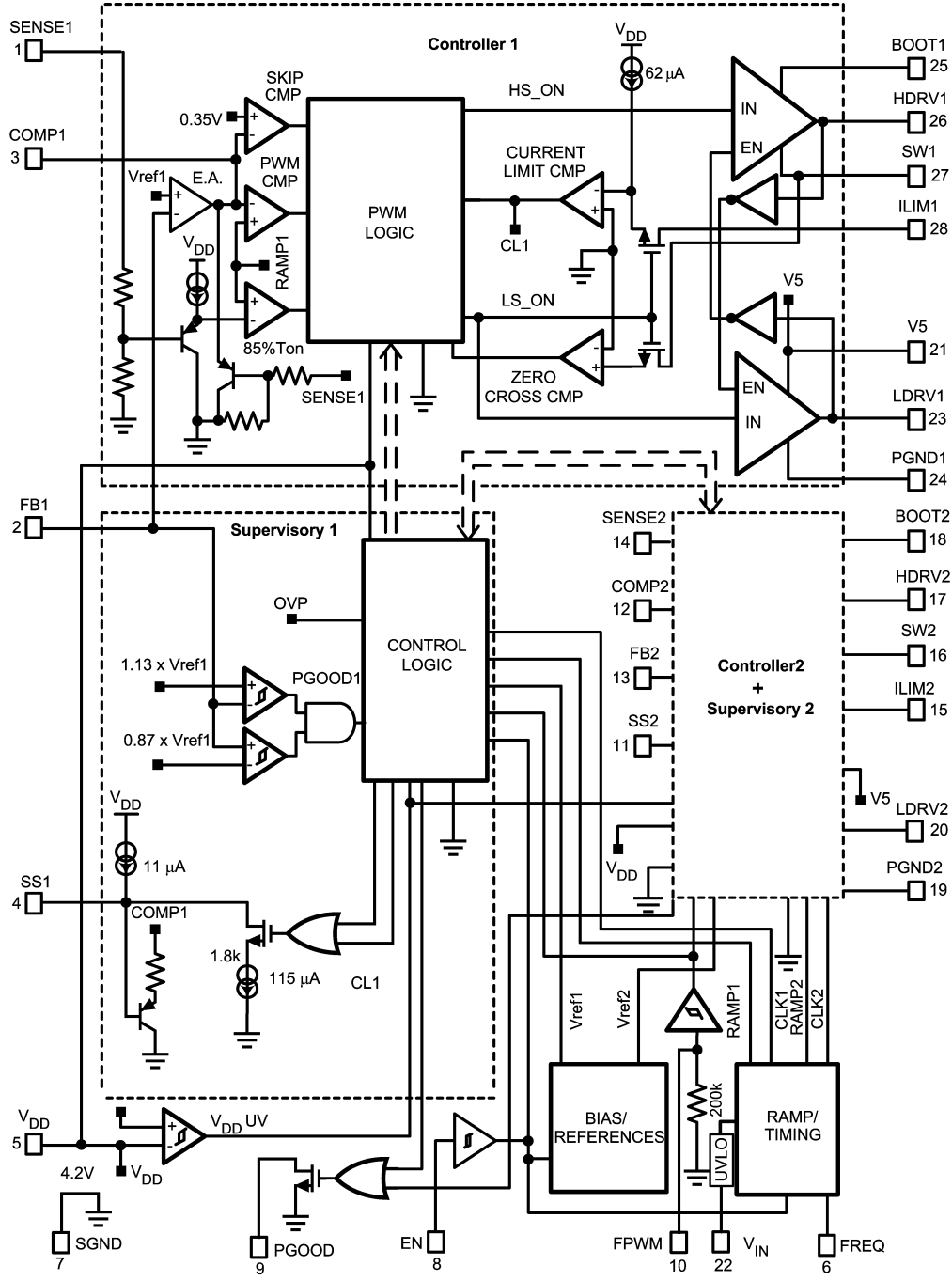

20134701

**Typical Performance Characteristics** The system efficiency plots below were measured using input voltages of 15V, 20V, 24V, 28V. These input voltages correspond with the uppermost curve to lowermost curve, respectively. The output current ( $I_O$ ) refers to simultaneous loading of both channels.

**System Efficiency for 5V/3.3V Outputs**

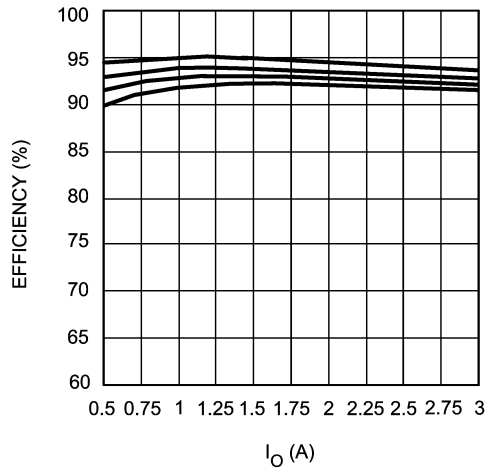

20134705

**System Efficiency for 2.5V/3.3V Outputs**

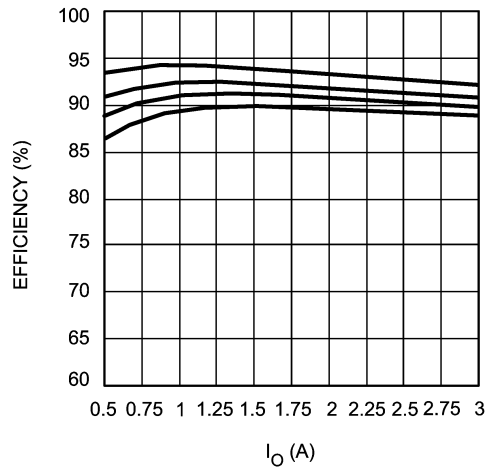

20134706

**System Efficiency for 1.8V/1.2V Outputs**

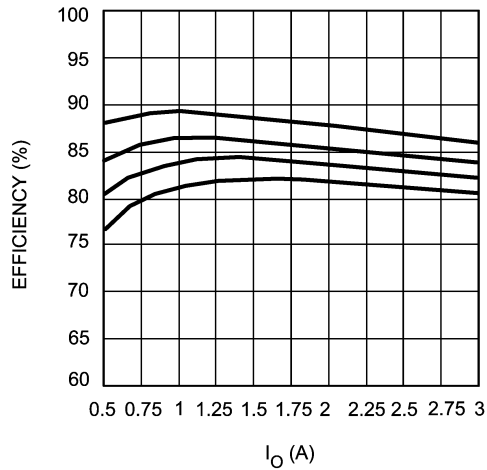

20134707

**System Max  $V_{OUT}$  For A Given  $V_{IN}$**   
 $T_J = 25^\circ\text{C}$

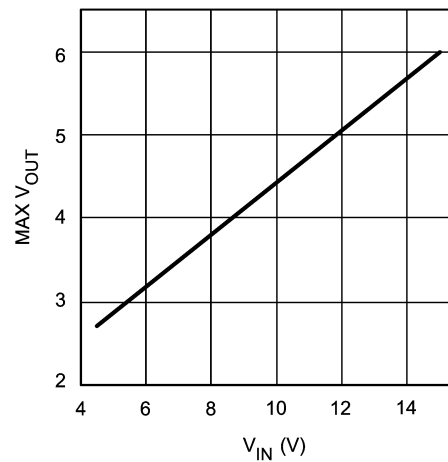

20134703

**Modulator (Plant) Gain**

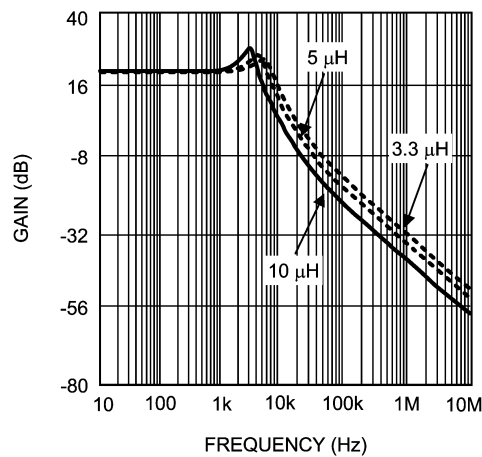

20134708

## Operation Descriptions

### GENERAL

The LM2657 provides two identical synchronously switched buck regulator channels that operate 180° out of phase. A voltage-mode control topology was selected to provide fixed-frequency PWM regulation at very low duty cycles, in preference to current-mode control, because the latter has inherent limitations in being able to achieve low pulse widths due to blanking time requirements. Because of a minimum pulse width of about 30ns for the LM2657, very low duty cycles (low output, high input) are possible. The main advantage of current-mode control is the fact that the slope of its ramp (derived from the switch current), automatically increases with an increase in input voltage. This leads to improved line rejection and fast response to line variations. In typical voltage-mode control, the ramp is derived from the clock, not from the switch current. But by using the input voltage together with the clock signal to generate the ramp as in the LM2657, this advantage of current-mode control can in fact be completely replicated. The technique is called line feedforward. In addition, the LM2657 features a user-selectable Pulse-skip mode that significantly improves efficiency at light loads by reducing switching losses and driver consumption, both of which are proportional to switching frequency.

### INPUT VOLTAGE FEEDFORWARD

The feedforward circuit of the LM2657 adjusts the slope of the internal PWM ramp in proportion to the regulator input voltage. See *Figure 1* for an illustration of how the duty cycle changes as a result of the change in the slope of the ramp, even though the error amplifier output has not had time to react to the line disturbance. The almost instantaneous duty cycle correction provided by the feedforward circuit significantly improves line transient rejection.

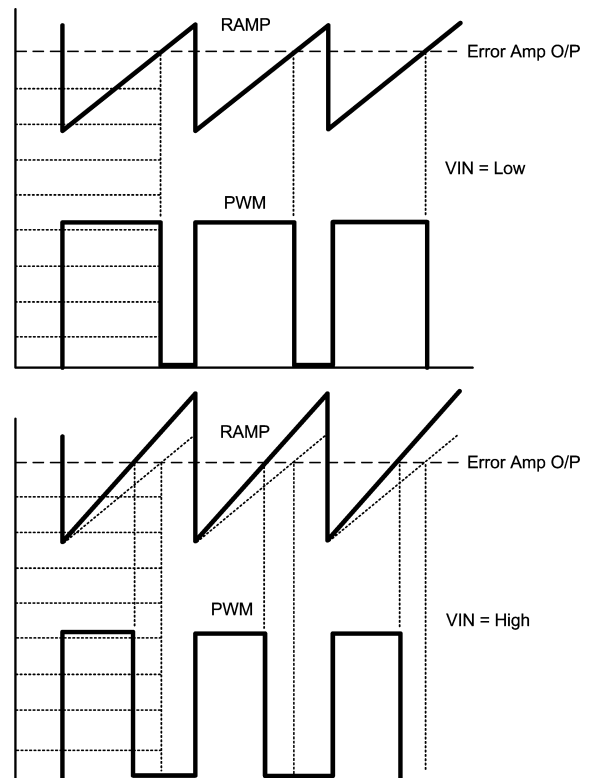

20134709

FIGURE 1. Voltage Feedforward

### FORCED-PWM MODE AND PULSE-SKIP MODE

Forced-PWM mode (FPWM) leads to Continuous Conduction Mode (CCM) even at very light loads. It is one of two user-selectable modes of operation provided by the LM2657. When FPWM is chosen (FPWM pin high), the bottom FET will always be turned ON whenever the top FET is OFF. See *Figure 2* for a typical FPWM plot.



20134710

CH1: HDRV, CH2: LDRV, CH3: SW, CH4:  $I_L$  (0.2A/div)  
Output 1V @ 0.04A,  $V_{IN}$  = 10V, FPWM, L = 10 $\mu$ H, f = 300kHz

FIGURE 2. Normal FPWM Mode Operation at Light Loads

## Operation Descriptions (Continued)

In a conventional converter, as the load is decreased to about 10-30% of maximum load current, DCM (Discontinuous Conduction Mode) occurs. In this condition the inductor current falls to zero during the OFF-time, and stays there until the start of the next switching cycle. In this mode, if the load is decreased further, the duty cycle decreases (pinches off), and ultimately may decrease to the point where the required pulse width becomes less than the minimum ON-time achievable by the converter (controller + FETs). Then a sort of random skipping behavior occurs as the error amplifier struggles to maintain regulation. There are two ways to prevent random pulse skipping from occurring.

One way is to keep the lower FET ON until the start of the next cycle (as in the LM2657 operated in FPWM mode). This allows the inductor current to drop to zero and then actually reverse direction (negative direction through inductor, passing from drain to source of lower FET, see Channel 4 in *Figure 2*). Now the current can continue to flow continuously until the end of the switching cycle. This maintains CCM and the duty cycle does not start to pinch off as in typical DCM. Nor does it lead to the undesirable random skipping described above. Note that the pulse width (duty cycle) for CCM is virtually constant for any load and therefore does not usually run into the minimum ON-time restriction. But it can happen, especially when the application consists of a very high input voltage, a low output voltage rail, and the switching frequency is set high. Let us check the LM2657 to rule out this remote possibility. For example, with an input of 24V, an output of 1V, the duty cycle is  $1/24 = 4.2\%$ . This leads to a required ON-time of  $0.042 \times 3.3\mu\text{s} = 0.14\mu\text{s}$  at a switching frequency of 300kHz ( $T=3.3\mu\text{s}$ ). Since 140ns exceeds the minimum ON-time of 30ns of the LM2657, normal constant frequency CCM mode of operation is assured in FPWM mode at virtually any load.

The second way to prevent random pulse skipping in discontinuous mode is the Pulse-skip (SKIP) Mode. In SKIP Mode, a zero-cross detector at the SW pin turns off the bottom FET when the inductor current decays to zero (actually at  $V_{\text{SW\_ZERO}}$ , see Electrical Characteristics table). This, however, would still amount to conventional DCM, with its attendant idiosyncrasies at extremely light loads as described earlier. The LM2657 avoids the random skipping behavior and replaces it with a more consistent SKIP mode. In conventional DCM, a converter would try to reduce its duty cycle from the CCM value as the load decreases, as explained previously. So it would start with the CCM duty cycle value (at the CCM-DCM boundary), but as the load decreases, the duty cycle would try to shrink to zero. However, in the LM2657, the DCM duty cycle is not allowed to fall below 85% of the CCM value. So when the theoretically required DCM duty cycle value falls below what the LM2657 is allowed to deliver (in this mode), pulse-skipping starts. It will be seen that several of these excess pulses may be delivered until the output capacitors charge up enough to notify the error amplifier and cause its output to reverse. Thereafter, several pulses could be skipped entirely until the output of the error amplifier again reverses. The SKIP mode therefore leads to a reduction in the average switching frequency. Switching losses and FET driver losses, both of which are proportional to frequency, are significantly reduced at very light loads and efficiency is boosted. SKIP mode also reduces the circulating currents and energy associated with the FPWM mode. See *Figure 3* for a typical plot of SKIP mode at very light loads. Note the bunching of several fixed-width pulses fol-

lowed by skipped pulses. The average frequency can actually fall very low at very light loads. When this happens the inductor core is seeing only very mild flux excursions, and no significant audible noise is created. But if EMI is a particularly sensitive issue for the particular application, the user can simply opt for the slightly less efficient, constant frequency FPWM mode.

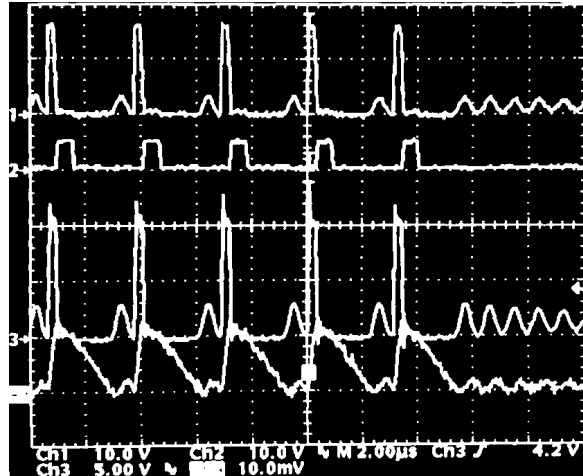

CH1: HDRV, CH2: LDRV, CH3: SW, CH4:  $I_L$  (0.2A/div)  
Output 1V @ 0.04A, VIN = 10V, SKIP, L = 10µH, f = 300kHz

**FIGURE 3. Normal SKIP Mode Operation at Light Loads**

The SKIP mode is enabled when the FPWM pin is held low (or left floating). At higher loads, and under steady state conditions (above CCM-DCM boundary), there will be absolutely no difference in the behavior of the LM2657 and the associated converter waveforms based on the voltage applied on the FPWM pin. The differences show up only at light loads.

Also, under startup, since the currents are high until the output capacitors have charged up, there will be no observable difference in the shape of the ramp-up of the output rails in either SKIP mode or FPWM mode. The design has thus forced the startup waveforms to be identical irrespective of whether the FPWM mode or the SKIP mode has been selected.

The designer must realize that even at zero load condition, there is circulating current when operating in FPWM mode. This is illustrated in *Figure 4*. Since duty cycle is the same as for conventional CCM, from  $V = L \cdot \Delta I / \Delta t$  it can be seen that  $\Delta I$  (or  $I_{pp}$  in *Figure 4*) must remain constant for any load, including zero. At zero load, the average current through the inductor is zero, so the geometric center of the sawtooth waveform (the center being always equal to load current) is along the x-axis. At critical conduction (boundary between conventional CCM and what should have been DCM were it not in FPWM mode), the load current is equal to  $I_{pp}/2$ . Note that excessively low values of inductance will produce much higher current ripple and this will lead to higher circulating currents and dissipation.

## Operation Descriptions (Continued)

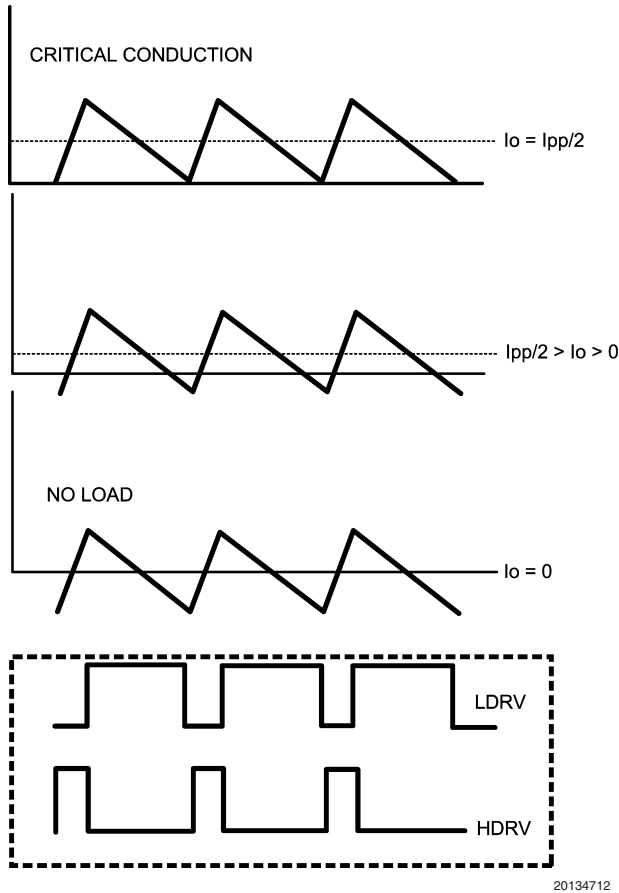

FIGURE 4. Inductor Current in FPWM Mode

### START-UP AND STATE-TRANSITIONS AT LIGHT LOADS

During startup the LM2657 is allowed to operate in SKIP mode regardless of the voltage on the FPWM pin. Starting in SKIP mode prevents the low-side FET from having to sink excessive amounts of negative current during start-up. This would occur if the output was pre-biased and the converter operated in FPWM mode. The FB pin would sense that the output was high and force a very low duty cycle, which would keep the low-side FET on longer than it should be in steady state. Without a load on the output the inductor current will reverse and become negative. This negative inductor current can be quite large depending on the voltage on the output and the size of the output capacitor.

A similar situation can occur if the converter transitions from SKIP mode to FPWM mode under a light load condition (converter is operating below the DCM boundary). This can occur after startup if FPWM mode is selected for use in a light load condition or if the FPWM pin is toggled high during normal operation at light load. The problem occurs because in SKIP mode the converter is operating at a set duty cycle and a lower average frequency. When the converter is forced into FPWM mode, this represents a change to the system. The pulse widths and frequency need to readjust suddenly and in the process momentary imbalances can be created. Like the case of a pre-biased load, there can be negative surge current passing from drain to source of the

lower FET. It must be kept in mind that though the LM2657 has current limiting for current passing in the 'positive' direction (positive with regards to the inductor, i.e. passing from source to drain of the lower FET), there is no limit for reverse currents. The amount of reverse current when the FPWM pin is toggled 'on the fly' can be very high. This current is determined by several factors. One key factor is the output capacitance. Large output capacitances will lead to higher peak reverse currents. The reverse swing will be higher for lighter loads because of the bigger difference between the duty cycles/average frequency in the two modes. See Figure 5 for a plot of what happened in going from SKIP to FPWM mode at 0A load (worst case). The peak reverse current was as high as 3A, lasting about 0.1ms. The inductor could also saturate severely at this point if designed for light loads. In general, if the designer wants to toggle the FPWM pin while the converter is operating or if FPWM mode is required for a light load application, the low side FET and inductor should be closely evaluated under this specific condition.

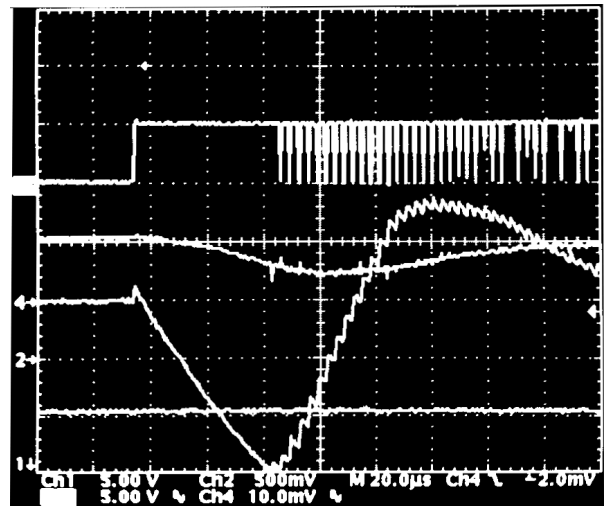

CH1: PGOOD, CH2: Vo, CH3: LDRV, CH4:  $I_L$  (1A/div)  
Output 1V @ 0A, VIN = 10V, L = 10µH, f = 300kHz

FIGURE 5. SKIP to FPWM 'On The Fly'

If the part is operated in FPWM mode with a light load the user will experience lower efficiency and negative current during the transition (as discussed). The user may also experience a momentary drop on Vout when the transition is made from SKIP to FPWM mode. This only occurs for no load or very light load conditions (above the DCM boundary there is no difference between SKIP FPWM modes).

In some cases, such as low Vout (<1.5V), a glitch may be present on PGOOD. If this is problematic, the glitch may be eliminated by either operating in SKIP mode or using a small sized soft start capacitor. See the following section for selecting soft start capacitors.

### SOFT-START

The maximum output voltage of the error amplifier is limited during start-up by the voltage on the 0.1µF capacitor connected between the SS pin and ground. When the controller is enabled (by taking EN pin high), the following steps may occur. First, the SS capacitor is discharged (if it has a pre-charge) by a 1.8 kΩ internal resistor ( $R_{SS\_DCHG}$ , see Electrical Characteristics). This ensures that reset is obtained. Note that reset is said to occur only when the voltage

## Operation Descriptions (Continued)

on *both* the SS pins falls below 100mV ( $V_{SS\_RESET}$ , see Electrical Characteristics table). Then a charging current source  $I_{SS\_CHG}$  of 11 $\mu$ A is applied at this pin to bring up the voltage of the Soft-start capacitor gradually. This causes the (maximum allowable) duty cycle to increase slowly, thereby limiting the charging current into the output capacitor and also ensuring that the inductor does not saturate. The Soft-start capacitor will eventually charge up close to the 5V input rail. When EN is pulled low the Soft-start capacitor is discharged by the same 1.8 k $\Omega$  internal resistor and the controller is shutdown. Now the sequence is allowed to repeat the next time EN is taken high.

One must be careful in selecting a soft start capacitor. Selecting a value that is too small will cause the switcher to go into current limit during startup. The minimum startup time may be estimated by the capacitor charging equation:

$$\Delta t_{STARTUP} = C_{OUT} \frac{\Delta V_{OUT}}{I_{CurrentLimit}}$$

### SHUTDOWN

When the EN pin is driven low, the LM2657 initiates shutdown by turning OFF both upper and lower FETs completely (this occurs irrespective of FPWM or SKIP modes). See *Figure 6* for a typical shutdown plot and note that the LDRV goes to zero (and stays there). Though not displayed, Power Good also goes low within less than 100ns of the EN pin going low ( $\Delta t_{SD}$ , see Electrical Characteristics table). Therefore in this case, the controller is NOT waiting for the output to actually fall out of the Power Good window before it signals Power Not Good.

When the part is shutdown with a constant current load, the time taken for the output to decay may be calculated using the equation  $\Delta V/\Delta t = i/C$ . For example, there is a constant current 2A load applied at the output and the charge stored on the output capacitor continues to discharge into the load. From  $\Delta V/\Delta t = i/C = 2A/330\mu F$ , it can be seen that the output voltage (say 1V) will fall to zero in about 165 $\mu$ s.

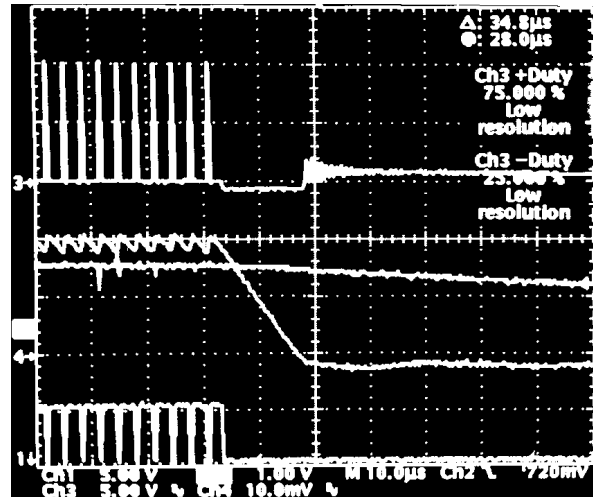

CH1: LDRV, CH2: Vo, CH3: SW, CH4:  $I_L$  (1A/div)

Output 1V @ 2A, VIN = 10V, FPWM/SKIP, L = 10 $\mu$ H, f = 300kHz,  $C_{OUT}$  = 330 $\mu$ F

FIGURE 6. Shutdown

### POWER GOOD/NOT GOOD SIGNALING

PGOOD is an open-drain output pin with an external pull-up resistor connected to 5V. It goes high (non-conducting) when both the outputs are within the regulation band as determined by the Power Good window detector stage on the feedback pin (see Block Diagram). PGOOD goes low (conducting) when either of the two outputs falls out of this window. This signal is referred to as Power Not Good. A glitch filter of 7 $\mu$ s filters out noise, and helps prevent spurious PGOOD responses. So Power Not Good is not asserted until 7 $\mu$ s after either of the two outputs have fallen out of the Power Good window (see  $\Delta t_{PG\_NOK}$  in Electrical Characteristics table). During power-up/Enable/recovery from a fault, the feedback pin voltage rises towards the regulation value. With the feedback pin rising, there is a 20 $\mu$ s delay between both the outputs being in regulation and the signaling of Power Good (see  $\Delta t_{PG\_OK}$  in Electrical Characteristics table).

Power Not Good is signaled within 100ns of the Enable pin being pulled low (see  $\Delta t_{SD}$  in Electrical Characteristics table), irrespective of the fact that the outputs could still be in regulation. The Soft-start capacitor is also then discharged as explained earlier.

### VIN POWER-OFF (UVLO)

The LM2657 has an internal comparator that monitors Vin. If Vin falls to approximately 4.2V, switching ceases and both top and bottom FETs are turned OFF. 'Power Not Good' has meanwhile already been signaled and a fault condition asserted shortly thereafter.

### VDD POWER-OFF (UVLO)

If VDD falls below approximately 4V, switching ceases and both top and bottom FETs are turned OFF. If VDD falls below about 1.8V, the part is disabled identically to EN being pulled low and the soft-start sequence is reset.

## Operation Descriptions (Continued)

### OVER-VOLTAGE PROTECTION

In addition to a Power Not Good fault being asserted, if the FB pin is above the PGOOD window, an over-voltage fault occurs. The low-side FET is turned ON and the high-side FET is turned OFF immediately. Normal operation will resume upon the next switching cycle where an over-voltage fault is not detected. If the fault persists, the low-side FET will stay on and the high-side FET will not turn back on until the FB pin falls within the power good window.

### CURRENT LIMIT AND PROTECTION

Output current limiting is achieved by sensing the negative  $V_{ds}$  drop across the low side FET when the FET is turned ON. The Current Limit Comparator (see Block Diagram) monitors the voltage at the ILIM pin with  $62\mu\text{A}$  (typical value) of current being sourced from the pin. The  $62\mu\text{A}$  source flows through an external resistor connected between ILIM and

the drain of the lower FET. The voltage drop across the ILIM resistor is compared with the drop across the lower FET and the current limit comparator trips when the two are of the same magnitude. This determines the threshold of current limiting. For example, if excessive inductor current causes the voltage across the lower FET to exceed the voltage drop across the ILIM resistor, the ILIM pin will go negative (with respect to ground) and trip the comparator. The comparator then sets a latch that prevents the top FET from turning ON during the next PWM clock cycle. The top FET will resume switching only if the current limit comparator was not tripped in the previous switching cycle. This operates identically to an over-voltage fault.

Additionally, the Soft-start capacitor at the SS pin is discharged with a  $115\mu\text{A}$  current source when an overcurrent event is in progress. The purpose of discharging the Soft-start capacitor during an overcurrent event is to eventually allow the voltage on the SS pin to fall low enough to cause additional duty cycle limiting.



## Application Information

### SETTING OUTPUT VOLTAGE

When setting the output voltage, one should consider the maximum duty cycle constraints. The maximum duty cycle limits the maximum output voltage for a given input voltage (see Electrical Characteristics) according to the formula:

$$V_{OUT\_MAX} = D_{MAX} \times V_{IN}$$

One should also note that resistors R21, R15 are involved in setting the gain of the error amplifier for their respective channels. For the following example the value of  $R_T$  has been set to 43.2k $\Omega$  for both channels. In general, only the bottom resistor should be adjusted unless the compensation is modified. Open-loop gain information is provided in the next section should it be necessary to change both top and bottom resistor values.

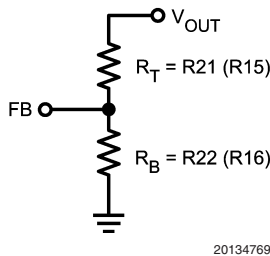

FIGURE 7. Component Designation

Output Voltage equation:

$$V_{OUT} = \frac{R_T + R_B}{R_B} V_{FB}$$

Rearranging, we can express the value of RB as simply:

$$R_B = \frac{R_T \times V_{FB}}{V_{OUT} - V_{FB}}$$

Therefore from the Bill of Materials (High Current Board, Figure 14):

For **Channel #1** ( $V_{OUT1} = 1.8V$ ),

$R_T = R21 = 43.2k\Omega$

$$R_B = \frac{43.2 k\Omega \times 0.6V}{1.8V - 0.6V}$$

$R_B = 21.6k\Omega$ , however the closest standard value is 21.5k $\Omega$ . Therefore

$R_B = R22 = 21.5k\Omega$

For **Channel #2** ( $V_{OUT2} = 1.2V$ ),

$R_T = R15 = 43.2k\Omega$

$$R_B = \frac{43.2 k\Omega \times 0.6V}{1.2V - 0.6V}$$

$R_B = 43.2k\Omega$  which is a standard value. Therefore

$R_B = R16 = 43.2k\Omega$

Looking again at the output voltage equation:

$$V_{OUT1} = \frac{(43.2 + 21.5) \times 0.6}{21.5} = 1.806V$$

$$V_{OUT2} = \frac{(43.2 + 43.2) \times 0.6}{43.2} = 1.2V$$

### OUTPUT FILTER

At this point the designer must consider the load requirements for output voltage ripple ( $V_{RIPPLE}$ ), voltage droop ( $V_{DROOP}$ ), and current ripple ( $I_{RIPPLE}$ ).

The following equation may be used in calculating an appropriate inductor value:

$$L = \frac{V_{OUT}(V_{IN} - V_{OUT})}{V_{IN} I_{RIPPLE} f_{SW}} 10^3$$

Where  $f_{SW}$  is in kHz and L is in  $\mu H$ .

From the relationship above it becomes apparent that there is a tradeoff between ripple current and inductor size. A good starting point for selecting an inductor is to set  $I_{RIPPLE}$  equal to 30% of the maximum load current.

Once an inductor has been selected, the capacitor value may be determined by considering the maximum load step (difference between maximum and minimum currents drawn by the load) and the acceptable level that the voltage will droop during that load step (typically not more than 2% of the output voltage). This relationship is given by the following:

$$C = \frac{L(I_{MAX} - I_{MIN})^2}{2V_{DROOP}(V_{IN} - V_{OUT})}$$

Where L is in  $\mu H$  and C is in  $\mu F$ .

Capacitors have a parasitic series resistance (ESR) that is responsible for voltage ripple in the output. To ensure that the capacitor will meet the given requirements, it must have an ESR not greater than the following:

$$ESR = \frac{V_{RIPPLE}}{I_{RIPPLE}}$$

The output capacitor must be able to withstand the load requirements by having a voltage and RMS current rating higher than the output voltage and RMS load current respectively. The RMS load current may be determined using the following relationship:

$$I_{RMS\_OUT} = \frac{I_{RIPPLE}}{\sqrt{12}}$$

Iteration is usually required to ensure the best overall solution for a given application.

Should the designer require a more detailed set of equations, application notes AN-1197 and AN-1207 available from [www.national.com](http://www.national.com) are an excellent resource.

## Application Information (Continued)

### MOSFET SELECTION

Selection of FETs for the controller must be done carefully taking into account efficiency, thermal dissipation and drive requirements. Typically the component selection is made according to the most efficient FET for a given price.

When looking for a FET, it is often helpful to compose a spreadsheet of key parameters. These parameters may be summarized as on resistance ( $R_{DS\_ON}$ ), gate charge ( $Q_{GS}$ ), rise and fall times ( $t_r$  and  $t_f$ ). The power dissipated in a given device may then be calculated according to the following equations:

High side FET:

$$P = P_C + P_{GC} + P_{SW}$$

Where

$$P_C = D \times (I_{OUT}^2 \times R_{DS\_ON})$$

$$P_{GC} = 5V \times Q_{GS} \times f$$

$$P_{SW} = 0.5 \times V_{IN} \times I_{OUT} \times (t_r + t_f) \times f$$

Low side FET:

$$P = P_C + P_{GC}$$

Where

$$P_C = (1 - D) \times (I_{OUT}^2 \times R_{DS\_ON})$$

$$P_{GC} = 5V \times Q_{GS} \times f$$

One will note that the gate charge requirements should be low to ensure good efficiency. However, if a FET's gate charge requirement is too low (less than 8nC), the FET can turn on spuriously. A good starting point for a 10A load is to use a high side and low side FET each with an on resistance of 5m $\Omega$  (FET on resistance is a function of temperature, therefore it is advisable to apply the appropriate correction factor provided in the FET datasheet), gate to source charge of 8nC (total gate charge of 36 nC),  $t_r = 11$ ns,  $t_f = 47$ ns, and temp coefficient of 1.4. For a 5V input and 1.2V/10A output ( $f = 300$ kHz), this yields a power dissipation of 0.62 W (high side FET) and 0.54 W (low side FET). The efficiency (Efficiency =  $\frac{P_{OUT}}{P_{OUT} + P_{Low\_Side\_FET} + P_{High\_Side\_FET} + V_{IN} \times I_Q}$ ) is then 91%. While the same FET may be used for both the high side and low side, optimal performance may not be realized.

### CURRENT LIMIT RESISTOR

The timing scheme implemented in the LM2657 makes it possible for the IC to continue monitoring an overcurrent condition and to respond appropriately every cycle. This is explained as follows:

Consider the LM2657 working under normal conditions, just before an overload occurs. After the end of a given ON-pulse (say 'ton1'), the LM2657 starts sampling the current in the low-side FET. This is the OFF-duration called 'toff1' in this analysis. If an overcurrent condition is detected during this OFF-duration 'toff1' the controller will decide to omit the next ON-pulse (which would have occurred during the duration 'ton2'). This is done by setting an internal 'overcurrent latch' which will keep HDRV low. The LDRV will now not only stay high during the present OFF-duration ('toff1') but during the duration of the next (omitted) ON-pulse ('ton2'), and then as expected also during the succeeding OFF-duration ('toff2'). But the 'overcurrent latch' is reset at the very start of the next OFF-duration 'toff2'. Therefore, if the overcurrent condition persists, it can be recognized during 'toff2' and a decision to skip the next ON-pulse (duration 'ton3') can be taken. Finally, several ON-pulses may get skipped until the current in the lower FET falls below the current limit threshold.

Note that about 150ns after LDRV first goes high (start of low-side conduction), the current monitoring starts. The peak current seen by the current limit detector is slightly lower than the peak inductor current.

To set the value of the current limiting resistor ( $R_{LIM}$ , between ILIM pin and SW pin), the function of the ILIM pin must be understood. Refer to *Figure 8* to see how the voltage on the ILIM pin changes as current ramps up.

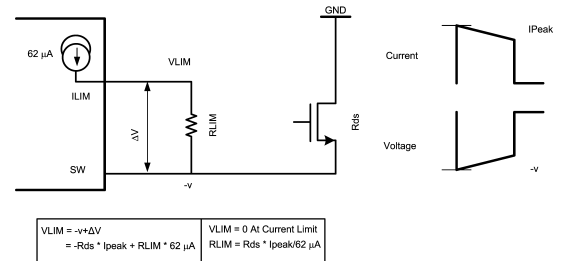

20134719

FIGURE 8. Understanding Current Sensing

For this analysis, the nominal value of current sourced ( $I_{LIM}$ , see Electrical Characteristics table) and the  $R_{DS\_ON}$  of the lower FET at 100°C should be used. This will ensure adequate headroom without the need for excessively large components. For the chosen low-side FET of the high current Evaluation board (Si4442DY), the typical  $R_{DS\_ON}$  at room temperature is 4.1m $\Omega$ , but this is not to be used here. The MAX FET  $R_{DS\_ON}$  at room temperature is 5m $\Omega$ . From the datasheet, at 100°C the  $R_{DS\_ON}$  goes up typically 1.4 times. Therefore, the  $R_{DS\_ON}$  to be used in the actual current limit calculation is  $1.4 \times 5\text{m}\Omega = 7\text{m}\Omega$ .

Using  $I_{LIM} = 62\mu\text{A}$  (see Electrical Characteristics table) and 7m $\Omega$  here will provide the lowest possible value of current limit considering tolerances and temperature (for a given  $R_{LIM}$  resistor). This limit must be set higher than the actual peak current in the converter under normal operation to ensure that full rated power can be delivered under all conditions by the converter without reaching the set current limit value.

At the point where current limiting occurs (peak inductor current becomes equal to current limit) the resistor for setting the current limit can be calculated. The (peak) current limit value depends on two factors:

- The peak current in the inductor with the converter delivering maximum rated load. This should be calculated at  $V_{inmax}$ .
- The 'overload margin' (above maximum load) that needs to be maintained. This will depend on the step loads likely to be seen in the application and the response expected.

The peak inductor current under normal operation (maximum load) depends on the load and the inductance. It is given by

$$I_{peak} = I_{OUT} + \frac{I_{RIPPLE}}{2}$$

where  $I_{RIPPLE}$  was determined in the output filter section.

**Example:** Let  $I_{RIPPLE}$  be 2A. The peak current under normal operation is

## Application Information (Continued)

$$I_{\text{peak}} = 10\text{A} + \frac{2\text{A}}{2} = 11\text{A}$$

Usually it is necessary to set the current limit about 20% higher than the peak inductor current. This overload margin helps handle sudden load changes. A 20% margin will require a current limit of  $11\text{A} \times 1.2 = 13.2\text{A}$  so RLIM will need to be

$$\text{RLIM} = \frac{R_{\text{ds}_{100}} \times I_{\text{CLIM}}}{62 \mu\text{A}}$$

$$\text{RLIM} = \frac{7 \text{ m}\Omega \times 13.2\text{A}}{62 \mu\text{A}} = 1.49 \text{ k}\Omega$$

A standard value of  $1.5\text{k}\Omega$  may be chosen.

A larger overload margin greater than 20% (say 40%) would help in obtaining good dynamic response. This is necessary if the load steps from an extremely low value (say zero) up to maximum load current. A larger current limit will, however, generate stresses in the FETs during abnormal load condition (such as a shorted output). A 40% overload margin equates to setting  $I_{\text{CLIM}}$  at  $15.4\text{A}$  ( $I_{\text{CLIM}} = 11\text{A} \times 1.4 = 15.4\text{A}$ ). This requires RLIM be  $7\text{m}\Omega \times 15.4\text{A} / 62\mu\text{A} = 1.73\text{k}\Omega$  (a standard value of  $1.74\text{k}\Omega$  may be chosen).

Summarizing, for a  $1.2\text{V}/10\text{A}$  rated output, using a  $1.9\mu\text{H}$  inductor and any low side equivalent FET (same  $R_{\text{DS\_ON}}$  as Si4442DY):

- For 20% overload margin, select current limit resistor to be  $1.5\text{k}\Omega$
- For 40% overload margin, select current limit resistor to be  $1.74\text{k}\Omega$

Repeating the calculation for a  $1\mu\text{H}$  inductor for a  $1.8\text{V}/20\text{A}$  rated output, and any low side equivalent FET (with the same  $R_{\text{DS\_ON}}$  as Si4838DY) we get the following requirement:

- For 20% overload margin, select current limit resistor to be  $1.87\text{k}\Omega$
- For 40% overload margin, select current limit resistor to be  $2.15\text{k}\Omega$

Note that if the lower FET  $R_{\text{DS\_ON}}$  is different from the one used on the Evaluation board, the current limit resistor RLIM must be recalculated according the new  $R_{\text{DS\_ON}}$ .

### INPUT CAPACITOR

For buck regulators, the input capacitor provides most of the pulsed current waveform demanded by the switch.

For the LM2657, there are two ways of calculating and meeting the input capacitance requirement. They are to use separate input capacitors for each channel or use a single capacitor for both channels.

By keeping separate input capacitors the possibility of interaction between the two channels is reduced, and the layout is less critical. Using two components also requires more board space and may be more costly.

The reason cost can be reduced when using one input capacitor in the LM2657 is because the two channels run

$180^\circ$  out of phase (interleaved switching). It can be shown that this dramatically reduces the ripple current requirement at the input. See Figure 9 for typical waveforms to understand how this happens.

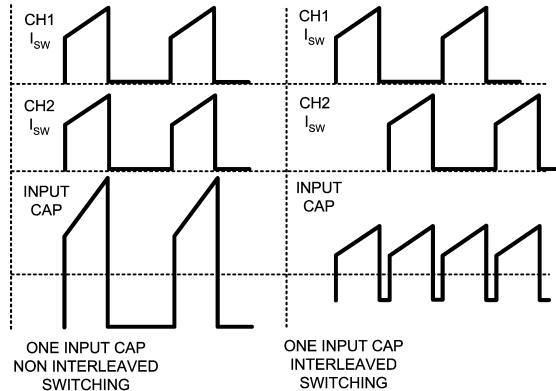

20134727

**FIGURE 9. Switch and Input Capacitor Currents**

**Example:** Consider two channels running at  $1.8\text{V}/20\text{A}$  and  $1.2\text{V}/10\text{A}$ . What is the worst case input capacitor RMS current if the input varies from  $5\text{V}$  to  $28\text{V}$ ?

**Step 1:** Call the output with the higher voltage as  $V_{\text{OUT}1}$  and the other as  $V_{\text{OUT}2}$ . Then find the ratio 'y' as shown below

$$y = \frac{V_{\text{OUT}2}}{V_{\text{OUT}1}} = \frac{1.2}{1.8} = 0.67$$

As a check, y should be less than or equal to 1 (since we said  $V_{\text{OUT}2} \leq V_{\text{OUT}1}$ ).

**Step 2:** The equation for the input current reveals that the worst-case occurs when the duty cycle of the first channel is:

$$D1 = \frac{I_{\text{OUT}1}^2 + (y \times I_{\text{OUT}2}^2)}{2 \times (I_{\text{OUT}1} + (I_{\text{OUT}2} \times y))^2}$$

So

$$D1 = \frac{20^2 + (0.67 \times 10^2)}{2 \times (20 + (10 \times 0.67))^2} = 0.33$$

Therefore, the input voltage to calculate the worst case RMS input current is:

$$V_{\text{IN}} = \frac{V_{\text{OUT}1}}{D1} = \frac{1.8}{0.33} = 5.49\text{V}$$

**Step 3:** Calculate the duty cycle of the other channel when this happens

$$D2 = \frac{V_{\text{OUT}2}}{V_{\text{IN}}} = 0.24$$

## Application Information (Continued)

**Step 4:** Calculate input capacitor RMS current by using the known equation

$$I_{IN} = \sqrt{(I_{OUT1}^2 \times D1) + (I_{OUT2}^2 \times D2) - [I_{OUT1} \times D1 + I_{OUT2} \times D2]^2}$$

$$I_{IN} = \sqrt{(20^2 \times 0.33) + (10^2 \times 0.24) - [(20 \times 0.33) + (10 \times 0.24)]^2}$$

Solving

$$I_{IN} = 8.66A$$

**Step 5:** The current calculated in Step 4 might not be the maximum current provided by the input capacitor. This is because we have only considered the case when both channels are loaded. In some cases, the maximum current is drawn from the input capacitor when a single channel is loaded.

Suppose one channel was completely unloaded. So in effect there is only a single output of 1.2V/10A. The equation for the RMS current through the input capacitor is then

$$I_{IN} = I_{OUT} \sqrt{D(1-D)}$$

The function  $D(1-D)$  has a maxima at  $D = 0.5$ . This would correspond to an input voltage of  $1.2V/0.5 = 2.4V$  (although the switcher is not operational at this input voltage, we will continue with the calculation). The input capacitor current at this worst case input voltage would be

$$I_{IN} = 10 \sqrt{0.5(1 - 0.5)} = 10 \times 0.5 = 5A$$

We must always take the higher of the two values calculated to ensure proper component selection.

Note, step 5 is used to calculate the input capacitor current requirements for either single channel operation or when using separate input capacitors.

In all cases, the input capacitor(s) must be positioned physically close to their respective stages. If separate input capacitors are being used for each channel, the input traces to the two inputs must be long and thin so as to introduce a measure of high frequency decoupling between the now separated stages.

The equations used in the above sections apply only if the duty cycles of both channels are less than or equal to 50% (and there is no overlap in the current waveforms).

### MODULATOR GAIN/COMPENSATION

The LM2657 may be used with type 3 compensation. A model illustrating the use of type 3 compensation is shown in Figure 10. Using this model we obtain the modulator transfer function:

$$H(s) = k \frac{(sA_1 + 1)(sA_2 + 1)}{s(sA_3 + A_4)(sA_5 + 1)}$$

where

$$A1 = R_3 C_2$$

$$A2 = C_1 (R_1 + R_2)$$

$$A3 = R_2 R_3 C_2 C_3$$

$$A4 = R_2 (C_2 + C_3)$$

$$A5 = R_1 C_1$$

$$k = 10V/V$$

$$s = j\omega$$

From this equation we make some approximations and say that

$$A_1 = 1/\omega_1 = R_3 C_2$$

$$A_2 = 1/\omega_2 \approx R_2 C_1$$

$$A_3 = 1/\omega_3 \approx R_3 C_3$$

$$A_4 = 1$$

$$A_5 = 1/\omega_4 \approx R_1 C_1$$

$$k \approx 10\omega_1 (R_1 / R_2)$$

Since the unity gain bandwidth of the error amplifier is taken as 6.5MHz, its effect on frequency response is ignored in this analysis.

The output filter transfer function may be expressed as:

$$H_O(s) = \frac{\frac{s}{\omega_{2A}} + 1}{\frac{s^2}{\omega_{1A}^2} + \frac{1}{Q} \frac{s}{\omega_{1A}} + 1}$$

Where

$$\omega_{1A} = \frac{1}{\sqrt{LC}}$$

$$\omega_{2A} = \frac{1}{CR_{ESR}}$$

$$Q = \frac{R_{LOAD}}{\sqrt{L/C}}$$

$$s = j\omega$$

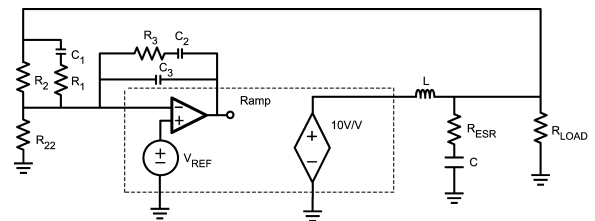

20134750

**FIGURE 10. LM2657 Closed Loop Model with Type 3 Compensation**

Component values may be selected according to the following guideline:

$$\omega_3 = \omega_{2A}, \omega_4 = 6.28 \times f_{SW}/2, \omega_1 = \omega_2 = \omega_{1A}.$$

## Application Information (Continued)

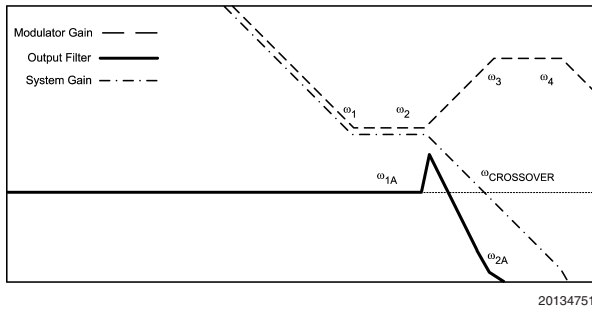

**FIGURE 11. Bode Magnitude Plot of Relative Pole and Zero Locations**

We start with an initial value for R2 and midband gain (gain between zeros  $\omega_1$  and  $\omega_2$ ). These values are typically  $R_2 = 43.2\text{k}\Omega$  and Midband gain = 15dB. To calculate the remaining component values

$$R_1 = \frac{1}{\omega_4 C_1}$$

$$R_3 = 10 \left( \frac{\text{MidbandGain}}{20} - 1 \right) R_2$$

$$C_1 = \frac{1}{\omega_2 R_2}$$

$$C_2 = \frac{\omega_2 R_2}{\omega_1 R_3} C_1$$

$$C_3 = \frac{1}{\omega_3 R_3}$$

This provides the user a fast and easy way of compensating the switcher.

When applying this guide, there are several things to keep in mind. The crossover frequency ( $f_{\text{CROSSOVER}} = \omega_{\text{CROSSOVER}}/6.28$ ) should be less than 1/5 the switching frequency. The designer should also consider the control loop damping. A phase margin ( $\phi_m$ ) of  $52^\circ$  is typically considered optimal. While this is typical, any phase margin between  $45^\circ$  and  $90^\circ$  should provide acceptable performance.

If a specific phase margin is desired, a more detailed design procedure may be employed.

A straightline approximation of the output filter, modulator, and system frequency response is shown in *Figure 11*. While the specific pole and zero locations will depend on the system variables, this plot may be used as a general guide.

A helpful approach in finding the appropriate values is to draw a straightline approximation of the output filters Bode phase plot. Using the approximate compensator pole and zero locations given, the designer may concern himself/

herself only with the placement of these poles and zeros. This is done to achieve the desired phase margin at the desired  $f_{\text{CROSSOVER}}$ .

Once a satisfactory phase margin is realized, the designer may concern himself/herself with the compensator gain. Since the pole and zero locations are known, all that remains is to make a Bode magnitude plot. A good starting point is at the crossover frequency. Starting at the crossover frequency the gain (zero at  $f_{\text{crossover}}$ ) and slope ( $-20 \text{ dB/Decade}$ ) are known. At this point it becomes quite easy to draw the remainder of the plot and calculate component values.

This approach is quite intuitive and provides an accurate way of compensating the switcher for a variety of component values.

### SNUBBER CIRCUITS

Some users may experience ringing on the switch pin. Ringing is caused by parasitic resonances in the circuit. Such resonances may produce excessive EMI or reduce efficiency. To prevent such problems, a 'snubber' circuit may be used as shown in *Figure 12*.

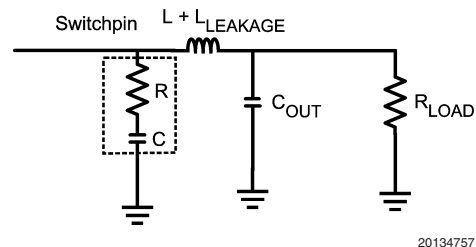

**FIGURE 12. Portion Of Circuit Containing Snubber (RC network in boxed diagram)**

Values are typically  $C \cong 4 \times$  Transistor Output Capacitance ( $C_{\text{DS}}$ ) and

$$R \approx \sqrt{L_{\text{Leakage}}/C_{\text{Transistor\_Output}}}$$

Typical values are  $C \cong 3300\text{pF}$  and  $R \cong 4.7\Omega$ . The snubber resistor should be able to dissipate at least  $P \cong f_{\text{SW}} C V_{\text{SW}}^2$ .

### LAYOUT GUIDELINES

When laying out the board, one should carefully consider the routing of the freq trace and surrounding traces. Any noise induced into this trace can cause jitter problems. These same routing guidelines and troubles apply to the VDD and V5 traces. A minimum  $0.1\mu\text{F}$  (ceramic) capacitor should be placed on the component side very close to the IC with no intervening vias between these capacitors and the VDD/SGND and V5/PGND pins respectively.

For high current applications, it is particularly important that  $C_{\text{IN}}$  be placed near the FETs. Also, the traces for each channel should be well separated to minimize cross talk between channels. In the critical path (path of highest current) the size of the traces should be carefully considered. Should thermal dissipation or resistive losses be a problem, one may connect layers of the board in parallel using vias.

For applications requiring low  $R_{\text{DS\_ON}}$  FETs, users may experience difficulty setting the current limit. This is due to the relative magnitude of the FETs resistance in comparison with

**Application Information** (Continued)

For more information on layout, consult 'Layout Guidelines' Application Note AN-1229.

the trace resistance. In instances such as this, the designer should minimize parasitic sources of resistance in the current limit traces.

20134767

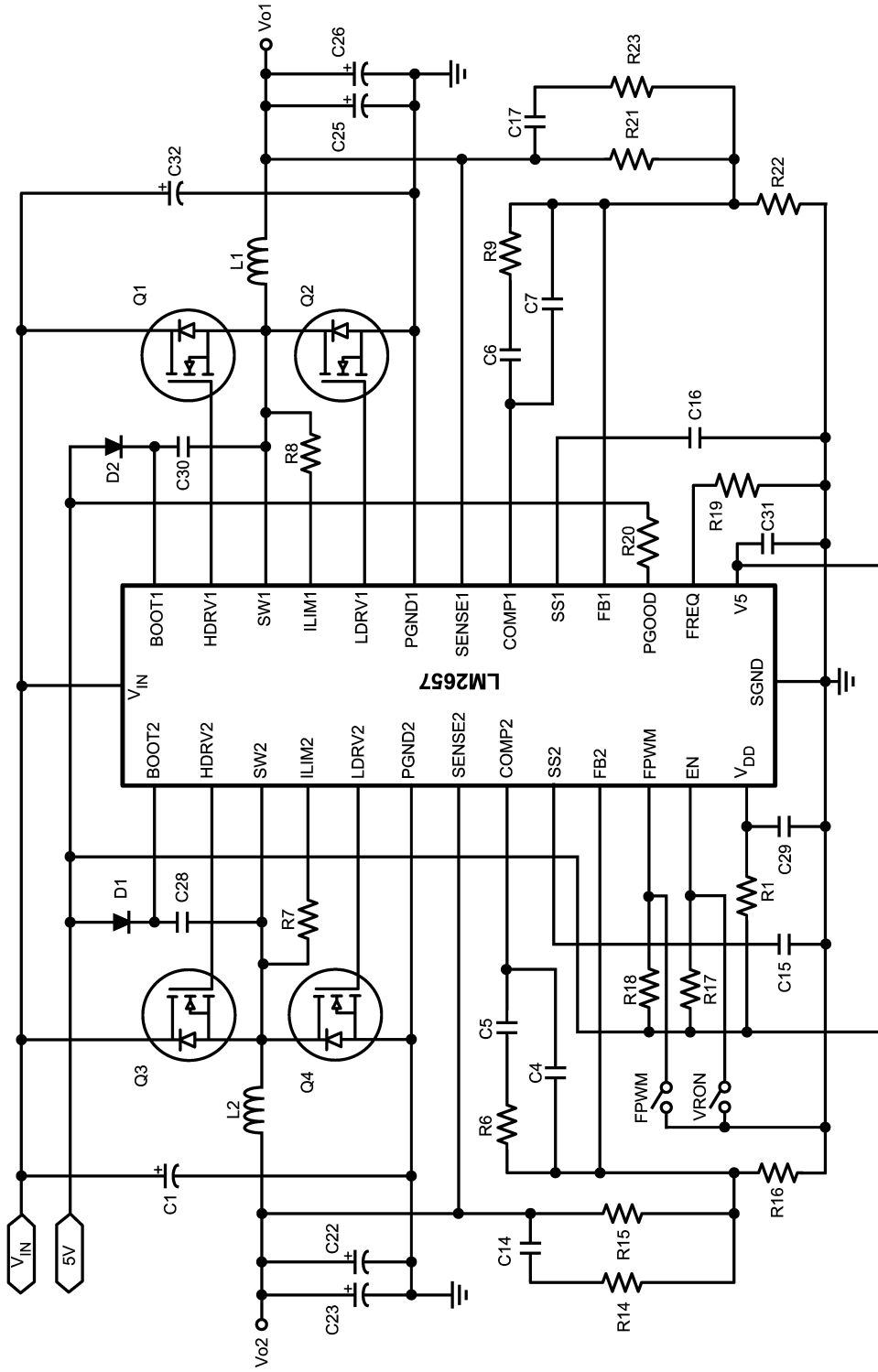
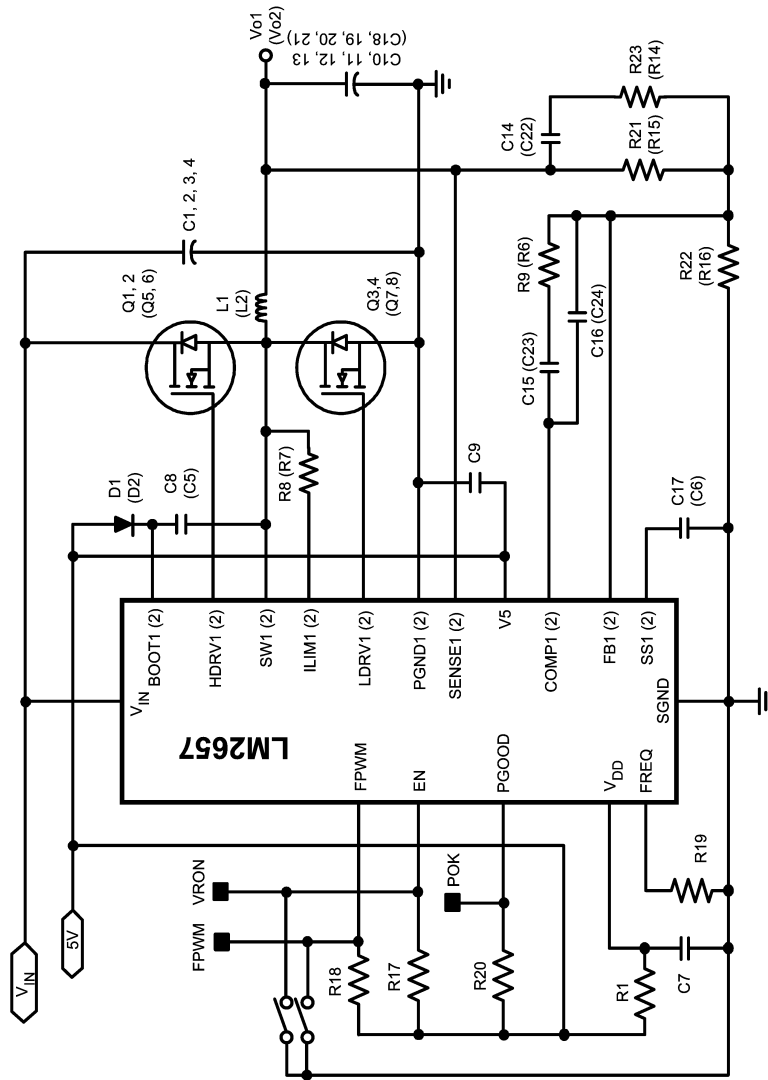

FIGURE 13. Typical Application (Expanded View)



High Current Application Circuit (Channel 2 in parenthesis)



20134780

FIGURE 14. High Current Application Circuit

**Bill of Materials (Figure 13)** (Low Current Board, 5V-to-2.5V at 1A and 5V-to-1.2V at 1A conversion).

Designator	Function	Description	Vendor	Part Number
C1	Cin	470 $\mu$ F	Sanyo	6MV470WG
C4	Comp Cap	180pF	Vishay	
C5	Comp Cap	2.7nF	Vishay	
C6	Comp Cap	2.7nF	Vishay	
C7	Comp Cap	150pF	Vishay	
C14	Cff (Ch2)	560pF	Vishay	
C15	Soft-start cap (Ch 2)	0.1 $\mu$ F	Vishay	
C16	Soft-start cap (Ch 1)	0.1 $\mu$ F	Vishay	
C17	Cff (Ch1)	680pf	Vishay	
C22	Output Cap (Ch2)	68 $\mu$ F	Sanyo	10TPE68M
C25	Output Cap (Ch1)	68 $\mu$ F	Sanyo	10TPE68M
C28	Cboot (Ch2)	0.1 $\mu$ F	Vishay	Ceramic
C29	V5 Decoupling	0.1 $\mu$ F	Vishay	Ceramic
C30	Cboot (Ch2)	0.1 $\mu$ F	Vishay	Ceramic
C31	V5 Decoupling	0.1 $\mu$ F	Vishay	Ceramic
C32	Cin - Optional	470 $\mu$ F	Sanyo	6MV470WG
R1	V5 to VDD Series pass	10, 5%	Vishay	
R6	Comp res (series with C, Ch2)	9.09k 1%	Vishay	
R7	Rlim (Ch 2)	909 1%	Vishay	
R8	Rlim (Ch 1)	866, 1%	Vishay	
R9	Comp Res (Series with C, Ch1)	11k 1%	Vishay	
R14	Rff (Ch 2)	1.74k 1%	Vishay	
R15	Res divider, upper (Ch 2)	43.2k 1%	Vishay	
R16	Res divider, lower (Ch 2)	43.2k 1%	Vishay	
R17	Enable pullup	12.7k 1%	Vishay	
R18	FPWM pullup	12.7k 1%	Vishay	
R19	Freq adj	22.1k 1%	Vishay	
R20	Pgood pullup	12.7k 1%	Vishay	
R21	Res divider, upper (Ch1)	43.2k 1%	Vishay	
R22	Res divider, lower (Ch1)	13.7k 1%	Vishay	
R23	Rff (Ch 1)	1.37k 1%	Vishay	
L1	Output Inductor (Ch1)	15 $\mu$ H	Coilcraft	DO1813P-472HC
L2	Output Inductor (Ch2)	10 $\mu$ H	Coilcraft	DO1813P-472HC
D1	Cboot diode (Ch 1)		Central	CMPD6263C-NST
D2	Cboot diode (Ch 2)		Central	CMPD6263C-NST
Q1	Upper FET (Ch 1)	Power FET	Vishay	Si9804DY
Q2	Lower FET (Ch1)	Power FET	Vishay	Si9804DY
Q4	Upper FET (Ch2)	Power FET	Vishay	Si9804DY
Q5	Lower FET (Ch2)	Power FET	Vishay	Si9804DY
U1	Controller	Controller	National	LM2657

## Bill of Materials (Figure 13)

(Typical Apps Board, 5V-to-2.5V at 5A and 5V-to-1.2V at 5A conversion)

Designator	Function	Description	Vendor	Part Number
C1	Cin	470 $\mu$ F	Sanyo	6MV470WG
C4	Comp Cap	4.7pF	Vishay	
C5	Comp Cap	1.2nF	Vishay	
C6	Comp Cap	1.2nF	Vishay	
C7	Comp Cap	4.7pF	Vishay	
C14	Cff (Ch2)	100pF	Vishay	
C15	Soft-start cap (Ch 2)	0.1 $\mu$ F	Vishay	
C16	Soft-start cap (Ch 1)	0.1 $\mu$ F	Vishay	
C17	Cff (Ch1)	100pf	Vishay	
C22	Output Cap (Ch2)	100 $\mu$ F	MuRata	GRM31CR60J226KE19L
C25	Output Cap (Ch1)	100 $\mu$ F	MuRata	GRM31CR60J226KE19L
C28	Cboot (Ch2)	0.1 $\mu$ F	Vishay	Ceramic
C29	V5 Decoupling	0.1 $\mu$ F	Vishay	Ceramic
C30	Cboot (Ch1)	0.1 $\mu$ F	Vishay	Ceramic
C31	V5 Decoupling	0.1 $\mu$ F	Vishay	Ceramic
C32	Cin - Optonal	470 $\mu$ F	Sanyo	6MV470WG
R1	V5 to VDD Series pass	10, 5%	Vishay	
R6	Comp res (series with C, Ch2)	136k 1%	Vishay	
R7	Rlim (Ch 2)	4.22k 1%	Vishay	
R8	Rlim (Ch 1)	4.32k, 1%	Vishay	
R9	Comp Res (Series with C, Ch1)	136k 1%	Vishay	
R14	Rff (Ch 2)	5.11k 1%	Vishay	
R15	Res divider, upper (Ch 2)	43.2k 1%	Vishay	
R16	Res divider, lower (Ch 2)	43.2k 1%	Vishay	
R17	Enable pullup	12.7k 1%	Vishay	
R18	FPWM pullup	12.7k 1%	Vishay	
R19	Freq adj	22.1k 1%	Vishay	
R20	Pgood pullup	12.7k 1%	Vishay	
R21	Res divider, upper (Ch1)	43.2k 1%	Vishay	
R22	Res divider, lower (Ch1)	13.7k 1%	Vishay	
R23	Rff (Ch 1)	5.1k 1%	Vishay	
L1	Output Inductor (Ch1)	4.7 $\mu$ H	Coilcraft	DO3316P-472HC
L2	Output Inductor (Ch2)	2.2 $\mu$ H	Coilcraft	DO3316P-472HC
D1	Cboot diode (Ch 1)		Central	CMPD6263C-NST
D2	Cboot diode (Ch 2)		Central	CMPD6263C-NST
Q1	Upper FET (Ch 1)	Power FET	Vishay	Si9804DY
Q2	Lower FET (Ch1)	Power FET	Vishay	Si9804DY
Q4	Upper FET (Ch2)	Power FET	Vishay	Si9804DY
Q5	Lower FET (Ch2)	Power FET	Vishay	Si9804DY
U1	Controller	Controller	National	LM2657

## Bill of Materials (Figure 14)

(High Current Board, 5V-to-1.8V@20A and 5V-to-1.2V@10A conversion)

Designator	Function	Description	Vendor	Part Number
C1,2,3,4	Cin (Ch 2)	(4) 1800 $\mu$ F	TDK	10MV1800WG
C5	Cboot (Ch2)	0.1 $\mu$ F	Vishay	Ceramic
C6	Soft-start cap (Ch 2)	0.1 $\mu$ F	Vishay	
C7	V5 Decoupling	0.1 $\mu$ F	Vishay	Ceramic
C8	Cboot (Ch2)	0.1 $\mu$ F	Vishay	Ceramic
C9	V5 Decoupling	0.1 $\mu$ F	Vishay	Ceramic
C10,11,12	Output Cap (Ch1)	2200 $\mu$ F	Sanyo	6MV2200WG
C14	Cff (Ch1)	680pf	Vishay	
C15	Comp Cap	680pF	Vishay	
C16	Comp Cap	15pF	Vishay	
C17	Soft-start cap (Ch 1)	0.1 $\mu$ F	Vishay	
C18,19,20	Output Cap (Ch2)	2200 $\mu$ F	Sanyo	6MV2200WG
C22	Cff (Ch2)	680pF	Vishay	
C23	Comp Cap	680pF	Vishay	
C24	Comp Cap	15pF	Vishay	
R1	V5 to VDD Series pass	10, 5%	Vishay	
R6	Comp res (series with C, Ch2)	57.6k 1%	Vishay	
R7	Rlim (Ch 2)	1.74k 1%	Vishay	
R8	Rlim (Ch 1)	2.15k, 1%	Vishay	
R9	Comp Res (Series with C, Ch1)	57.6k 1%	Vishay	
R14	Rff (Ch 2)	12.7k 1%	Vishay	
R15	Res divider, upper (Ch 2)	43.2k 1%	Vishay	
R16	Res divider, lower (Ch 2)	43.2k 1%	Vishay	
R17	Enable pullup	12.7k 1%	Vishay	
R18	FPWM pullup	12.7k 1%	Vishay	
R19	Freq adj	22.1k 1%	Vishay	
R20	Pgood pullup	12.7k 1%	Vishay	
R21	Res divider, upper (Ch1)	43.2k 1%	Vishay	
R22	Res divider, lower (Ch1)	21.5k 1%	Vishay	
R23	Rff (Ch 1)	12.7k 1%	Vishay	
L1	Output Inductor (Ch1)	1 $\mu$ H	Coilcraft	SER2009-102MX
L2	Output Inductor (Ch2)	1.9 $\mu$ H	TDK	RLF12560T-1R9N120
D1	Cboot diode (Ch 1)		Central	CMPD6263C-NST
D2	Cboot diode (Ch 2)		Central	CMPD6263C-NST
Q1	Upper FET (Ch 1)	Power FET	Vishay	Si4838Dy
Q2	Lower FET (Ch1)	Power FET	Vishay	Si4838Dy
Q4	Upper FET (Ch2)	Power FET	Vishay	Si4442Dy
Q5	Lower FET (Ch2)	Power FET	Vishay	Si4442Dy
U1	Controller	Controller	National	LM2657

In the BOMs listed above, the user has the option of using certain components in parallel. For example, in the typical apps board, C22 is a 100 $\mu$ F capacitor and C23 is optional. The user now has the option of using (2) 47 $\mu$ F capacitors. If this is done the compensation will need to be changed accordingly (C4 will be approximately half its original value.)

**Physical Dimensions** inches (millimeters) unless otherwise noted

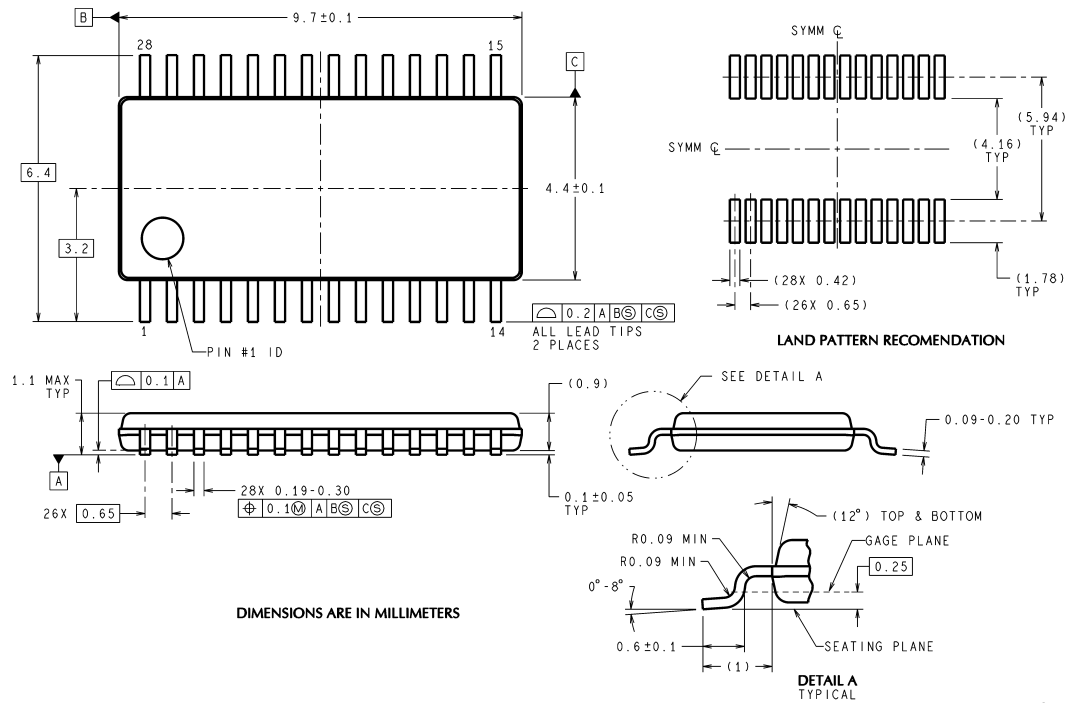

**28-Lead TSSOP Package**  
**NS Package Number MTC28**

MTC28 (Rev D)

National does not assume any responsibility for use of any circuitry described, no circuit patent licenses are implied and National reserves the right at any time without notice to change said circuitry and specifications.

For the most current product information visit us at [www.national.com](http://www.national.com).

**LIFE SUPPORT POLICY**

NATIONAL'S PRODUCTS ARE NOT AUTHORIZED FOR USE AS CRITICAL COMPONENTS IN LIFE SUPPORT DEVICES OR SYSTEMS WITHOUT THE EXPRESS WRITTEN APPROVAL OF THE PRESIDENT AND GENERAL COUNSEL OF NATIONAL SEMICONDUCTOR CORPORATION. As used herein:

1. Life support devices or systems are devices or systems which, (a) are intended for surgical implant into the body, or (b) support or sustain life, and whose failure to perform when properly used in accordance with instructions for use provided in the labeling, can be reasonably expected to result in a significant injury to the user.
2. A critical component is any component of a life support device or system whose failure to perform can be reasonably expected to cause the failure of the life support device or system, or to affect its safety or effectiveness.

**BANNED SUBSTANCE COMPLIANCE**

National Semiconductor manufactures products and uses packing materials that meet the provisions of the Customer Products Stewardship Specification (CSP-9-111C2) and the Banned Substances and Materials of Interest Specification (CSP-9-111S2) and contain no "Banned Substances" as defined in CSP-9-111S2.

**National Semiconductor**  
Americas Customer Support Center  
Email: [new.feedback@nsc.com](mailto:new.feedback@nsc.com)  
Tel: 1-800-272-9959

**National Semiconductor**  
Europe Customer Support Center  
Fax: +49 (0) 180-530 85 86  
Email: [europa.support@nsc.com](mailto:europa.support@nsc.com)  
Deutsch Tel: +49 (0) 69 9508 6208  
English Tel: +44 (0) 870 24 0 2171  
Français Tel: +33 (0) 1 41 91 8790

**National Semiconductor**  
Asia Pacific Customer Support Center  
Email: [ap.support@nsc.com](mailto:ap.support@nsc.com)

**National Semiconductor**  
Japan Customer Support Center  
Fax: 81-3-5639-7507  
Email: [jpn.feedback@nsc.com](mailto:jpn.feedback@nsc.com)  
Tel: 81-3-5639-7560

## IMPORTANT NOTICE

Texas Instruments Incorporated and its subsidiaries (TI) reserve the right to make corrections, modifications, enhancements, improvements, and other changes to its products and services at any time and to discontinue any product or service without notice. Customers should obtain the latest relevant information before placing orders and should verify that such information is current and complete. All products are sold subject to TI's terms and conditions of sale supplied at the time of order acknowledgment.

TI warrants performance of its hardware products to the specifications applicable at the time of sale in accordance with TI's standard warranty. Testing and other quality control techniques are used to the extent TI deems necessary to support this warranty. Except where mandated by government requirements, testing of all parameters of each product is not necessarily performed.

TI assumes no liability for applications assistance or customer product design. Customers are responsible for their products and applications using TI components. To minimize the risks associated with customer products and applications, customers should provide adequate design and operating safeguards.

TI does not warrant or represent that any license, either express or implied, is granted under any TI patent right, copyright, mask work right, or other TI intellectual property right relating to any combination, machine, or process in which TI products or services are used. Information published by TI regarding third-party products or services does not constitute a license from TI to use such products or services or a warranty or endorsement thereof. Use of such information may require a license from a third party under the patents or other intellectual property of the third party, or a license from TI under the patents or other intellectual property of TI.

Reproduction of TI information in TI data books or data sheets is permissible only if reproduction is without alteration and is accompanied by all associated warranties, conditions, limitations, and notices. Reproduction of this information with alteration is an unfair and deceptive business practice. TI is not responsible or liable for such altered documentation. Information of third parties may be subject to additional restrictions.

Resale of TI products or services with statements different from or beyond the parameters stated by TI for that product or service voids all express and any implied warranties for the associated TI product or service and is an unfair and deceptive business practice. TI is not responsible or liable for any such statements.

TI products are not authorized for use in safety-critical applications (such as life support) where a failure of the TI product would reasonably be expected to cause severe personal injury or death, unless officers of the parties have executed an agreement specifically governing such use. Buyers represent that they have all necessary expertise in the safety and regulatory ramifications of their applications, and acknowledge and agree that they are solely responsible for all legal, regulatory and safety-related requirements concerning their products and any use of TI products in such safety-critical applications, notwithstanding any applications-related information or support that may be provided by TI. Further, Buyers must fully indemnify TI and its representatives against any damages arising out of the use of TI products in such safety-critical applications.

TI products are neither designed nor intended for use in military/aerospace applications or environments unless the TI products are specifically designated by TI as military-grade or "enhanced plastic." Only products designated by TI as military-grade meet military specifications. Buyers acknowledge and agree that any such use of TI products which TI has not designated as military-grade is solely at the Buyer's risk, and that they are solely responsible for compliance with all legal and regulatory requirements in connection with such use.

TI products are neither designed nor intended for use in automotive applications or environments unless the specific TI products are designated by TI as compliant with ISO/TS 16949 requirements. Buyers acknowledge and agree that, if they use any non-designated products in automotive applications, TI will not be responsible for any failure to meet such requirements.

Following are URLs where you can obtain information on other Texas Instruments products and application solutions:

### Products

Audio	<a href="http://www.ti.com/audio">www.ti.com/audio</a>
Amplifiers	<a href="http://amplifier.ti.com">amplifier.ti.com</a>
Data Converters	<a href="http://dataconverter.ti.com">dataconverter.ti.com</a>
DLP® Products	<a href="http://www.dlp.com">www.dlp.com</a>
DSP	<a href="http://dsp.ti.com">dsp.ti.com</a>
Clocks and Timers	<a href="http://www.ti.com/clocks">www.ti.com/clocks</a>
Interface	<a href="http://interface.ti.com">interface.ti.com</a>
Logic	<a href="http://logic.ti.com">logic.ti.com</a>
Power Mgmt	<a href="http://power.ti.com">power.ti.com</a>
Microcontrollers	<a href="http://microcontroller.ti.com">microcontroller.ti.com</a>
RFID	<a href="http://www.ti-rfid.com">www.ti-rfid.com</a>
OMAP Mobile Processors	<a href="http://www.ti.com/omap">www.ti.com/omap</a>
Wireless Connectivity	<a href="http://www.ti.com/wirelessconnectivity">www.ti.com/wirelessconnectivity</a>

### Applications

Communications and Telecom	<a href="http://www.ti.com/communications">www.ti.com/communications</a>
Computers and Peripherals	<a href="http://www.ti.com/computers">www.ti.com/computers</a>
Consumer Electronics	<a href="http://www.ti.com/consumer-apps">www.ti.com/consumer-apps</a>
Energy and Lighting	<a href="http://www.ti.com/energy">www.ti.com/energy</a>
Industrial	<a href="http://www.ti.com/industrial">www.ti.com/industrial</a>
Medical	<a href="http://www.ti.com/medical">www.ti.com/medical</a>
Security	<a href="http://www.ti.com/security">www.ti.com/security</a>
Space, Avionics and Defense	<a href="http://www.ti.com/space-avionics-defense">www.ti.com/space-avionics-defense</a>
Transportation and Automotive	<a href="http://www.ti.com/automotive">www.ti.com/automotive</a>
Video and Imaging	<a href="http://www.ti.com/video">www.ti.com/video</a>

TI E2E Community Home Page

[e2e.ti.com](http://e2e.ti.com)

Mailing Address: Texas Instruments, Post Office Box 655303, Dallas, Texas 75265  
Copyright © 2011, Texas Instruments Incorporated