

April 7, 1998

TEL:805-498-2111 FAX:805-498-3804 WEB:http://www.semtech.com

DESCRIPTION

The LM2575/6 series switching regulators are monolithic integrated circuits designed for use in "buck" or "buck/boost" regulator applications requiring accurate output voltages over combined variations of line, load and temperature. This unique series greatly simplifies switching power supply design. The LM2575 has a maximum output current of 1A and the LM2576 is rated for 3A.

The LM2575/6 series miniconverters include a switching regulator and compensation network all within the same package. Just add a choke, catch diode and two capacitors to obtain an efficient DC-to-DC converter. Current limit and thermal shutdown features of the LM2575/6 series fully protect the device against overstress conditions.

The LM2575/6 series offers an alternative to popular 3 terminal linear regulators by providing higher efficiency with reduced heatsink size. In many applications a heat sink will not be required.

BLOCK DIAGRAM

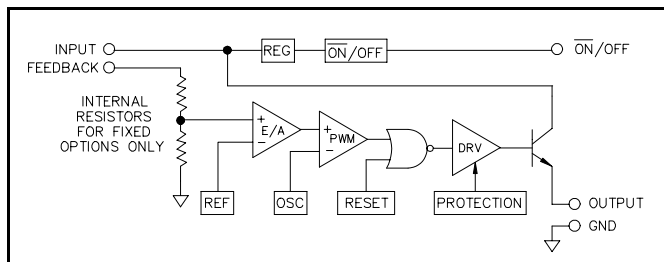

ORDERING INFORMATION

DEVICE ⁽¹⁾	PACKAGE	CURRENT
LM2575T-XX	TO-220 ⁽²⁾	1A
LM2575S-XX	TO-263 ⁽³⁾	
LM2576T-XX	TO-220 ⁽²⁾	3A
LM2576S-XX	TO-263 ⁽³⁾	

Notes:

(1) XX = Voltage Option 3.3, 5.0, 12, and ADJ (1.23V to 35V).

(2) T-XX = Straight in-line; T-XX-V = Vertical Staggered; T-XX-H = Horizontal Staggered.

(3) Add suffix 'TR' for tape and reel (TO-263).

FEATURES

- Pin for pin interchangeable with National's LM2575/LM2576 series
- DC-to-DC buck or buck/boost converter requiring only 4 support components
- Fixed or adjustable voltages
- Preset output voltages of 3.3, 5 and 12V
- Wide output voltage range, 1.23 to 35V
- 82% typical efficiency @ 5V
- Wide input voltage range, 4V to 40V
- Inhibit/enable control pin

ABSOLUTE MAXIMUM RATINGS

Parameter	Symbol	Maximum	Units
Input Voltage	V_{IN}	45	V
On/Off Pin Input Voltage		$-0.3 \leq V \leq V_{IN}$	V
Output Voltage to Common (Steady State)		-1	V
Power Dissipation	P_D	Internally Limited	W
Thermal Resistance Junction to Case TO-220 TO-263	θ_{JC}	2.0 2.0	°C/W
Thermal Resistance Junction to Ambient TO-220 TO-263	θ_{JA}	55 60	°C/W
Operating Junction Temperature Range	T_J	-40 to 125	°C
Storage Temperature Range	T_{STG}	-40 to 125	°C
Lead Temperature (Soldering) 10 Sec	T_{LEAD}	260	°C
ESD Class		2	

April 7, 1998

ELECTRICAL CHARACTERISTICS

 Unless otherwise specified, $V_{IN} = 12V$ for 3.3V, 5V and ADJ options; 25V for 12V; $V_{OUT} = 5V$ for ADJ, $T_J = 25^\circ C$.
 V_{IN} rated = 40V; $I_o = 0.5$ to 3A (LM2576), 0.2 to 1A (LM2575).

Parameter	Symbol	Test Conditions			Test Limits			Units
		V_{IN}	I_o	$T_J^{(4)}$	Min	Typ	Max	
Output Voltage LM2576-3.3	V_o		0.5A		3.23	3.30	3.37	V
		8V to V_{IN} Rated		O.T.	3.14	3.30	3.47	
					3.20	3.30	3.40	
LM2576-5	V_o		0.5A		4.90	5.00	5.10	V
		8V to V_{IN} Rated		O.T.	4.76	5.00	5.25	
					4.85	5.00	5.15	
LM2576-12	V_o		0.5A		11.76	12.00	12.24	V
		15V to V_{IN} Rated		O.T.	11.40	12.00	12.60	
					11.52	12.00	12.48	
Feedback Voltage $V_{OUT} = 5V$ LM2576-ADJ	I_{FB}		0.5A		1.217	1.230	1.243	V
		8V to V_{IN} Rated		O.T.	1.180	1.230	1.280	
					1.193	1.230	1.267	
Feedback Bias Current LM2576-ADJ	I_B	12V	0.5A			50	100	nA
				O.T.			500	
Output Voltage LM2575-3.3	V_o		0.2A		3.23	3.30	3.37	V
		8V to V_{IN} Rated		O.T.	3.14	3.30	3.47	
					3.20	3.30	3.40	
LM2575-5	V_o		0.2A		4.90	5.00	5.10	V
		8V to V_{IN} Rated		O.T.	4.75	5.00	5.25	
					4.85	5.00	5.15	
LM2575-12	V_o		0.2A		11.76	12.00	12.24	V
		15V to V_{IN} Rated		O.T.	11.40	12.00	12.60	
					11.52	12.00	12.48	
Feedback Voltage $V_{OUT} = 5V$ LM2575-ADJ	I_{FB}		0.2A		1.217	1.230	1.243	V
		8V to V_{IN} Rated		O.T.	1.180	1.230	1.280	
					1.193	1.230	1.267	
Feedback Bias Current LM2575-ADJ	I_B	12V	0.2A	O.T.			500	nA

(CONTINUED NEXT PAGE)

April 7, 1998

ELECTRICAL CHARACTERISTICS (cont.)

Parameter	Symbol	Test Conditions			Test Limits			Units
		V _{IN}	I _o	T _J ⁽⁴⁾	Min	Typ	Max	
Efficiency/Option	η	12V	LM2575-1A			77		%
3.3			LM2576-3A			82		
5		15V	88					
12		12V	82					
ADJ V _O = 5V								
Switching Frequency	F _{SW}				47	52	58	kHz
				O.T.	43	52	62	
Saturation Voltage ⁽¹⁾	V _{SAT}		LM2575-1A	O.T.		0.9	1.2	V
			LM2576-3A	O.T.		0.9	1.4	
Max Duty Cycle (On) ⁽³⁾	DC				93	98		%
Current Limit ⁽¹⁾	I _{CL}				4.2	5.8	6.9	A
Peak Current LM2576				O.T.	3.5		7.5	
Peak Current LM2575	I _{CL}				1.7	2.2	3.0	A
				O.T.	1.3		3.2	
Output Leakage Current ⁽²⁾	I _L	V _{IN} RATED					2	mA
Output = 0V								
Output = -1V						7.5	30	
Quiescent Current ⁽²⁾	I _Q					5	10	mA
				O.T.			12	
Standby Quiescent Current (On/Off Pin = 5V)	I _{STBY}					50		μA
				O.T.		50	500	
On/Off Pin Logic Input Level	V _{IH}				2.2	1.4		V
V _{OUT} = 0V					O.T.	2.4	1.4	
V _{OUT} = Option	V _{IL}					1.2	1.0	V
					O.T.		1.2	
On/Off Input Current								μA
On/Off = 5V (Off)	I _{IH}		0.5A			12	30	
On/Off = 0V (On)	I _{IL}		0.5A			0	10	

NOTES:

- (1) Output sourcing current-resistive load, no inductor or capacitor.
- (2) Feedback = V_O + 1.0V.
- (3) Feedback = 0V.
- (4) Over Temp. (O.T.) = over specified operating junction temperature range.

April 7, 1998

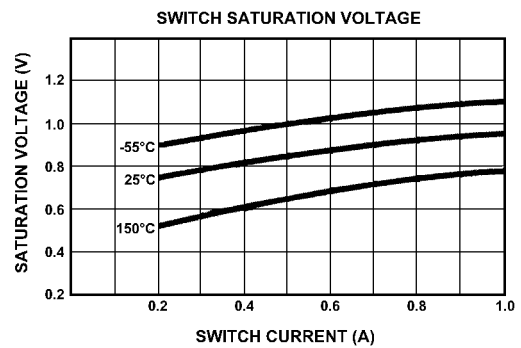
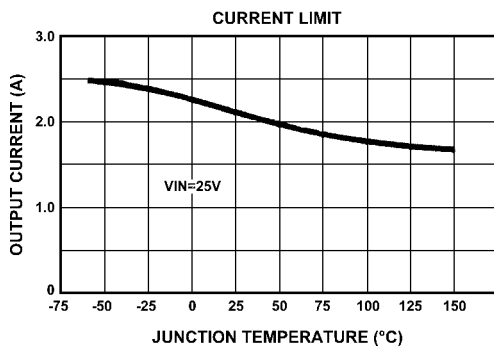
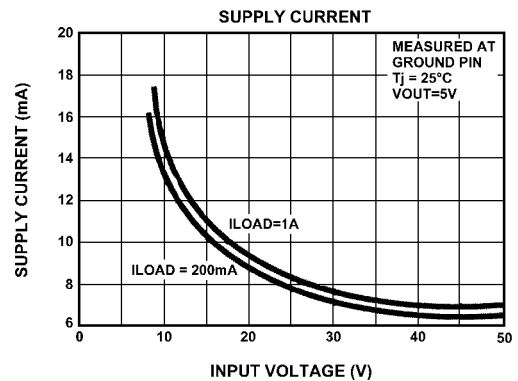
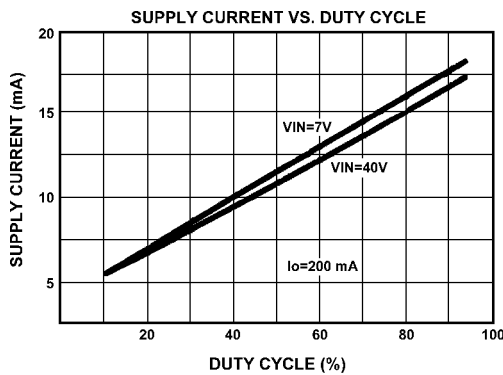
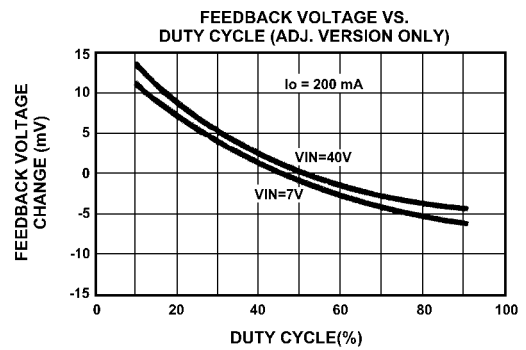
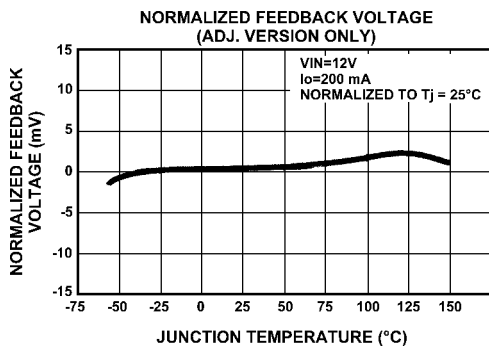
LM2575 - OPERATIONAL DATA

April 7, 1998

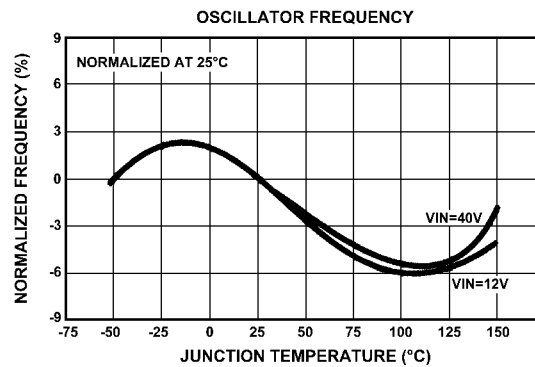
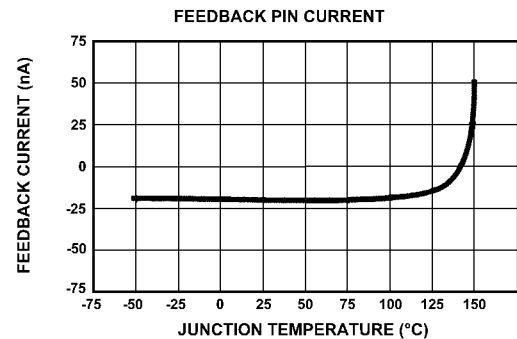
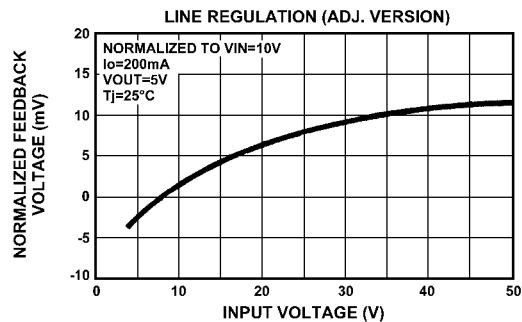
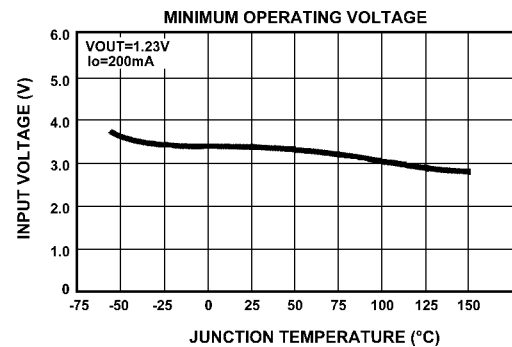
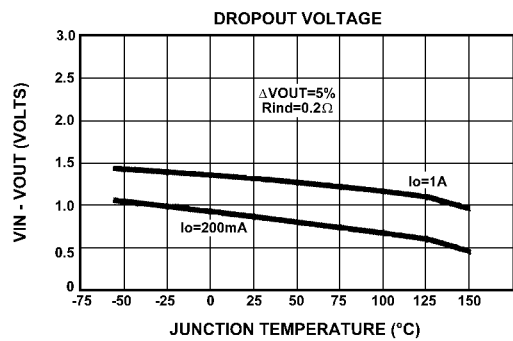
LM2575 - OPERATIONAL DATA

April 7, 1998

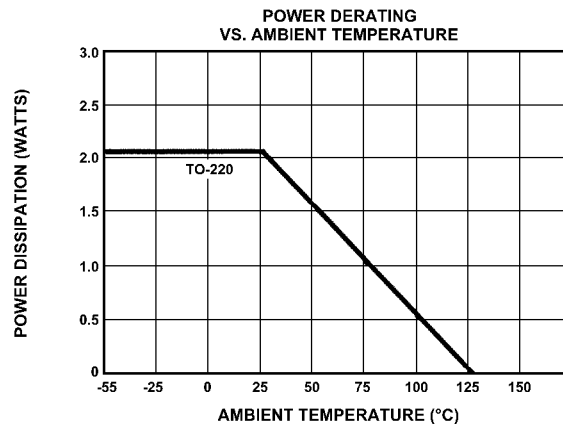
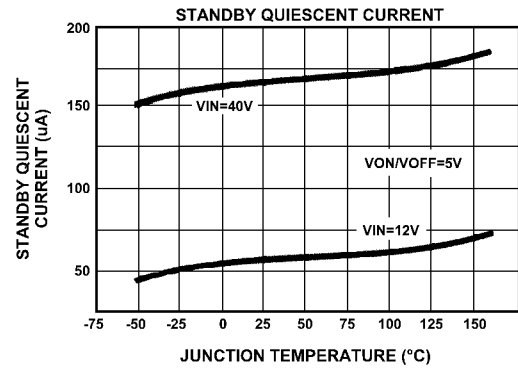
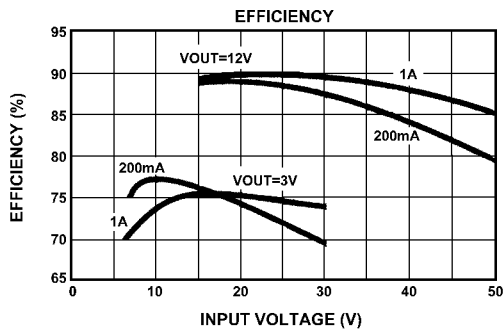
LM2575 - OPERATIONAL DATA

April 7, 1998

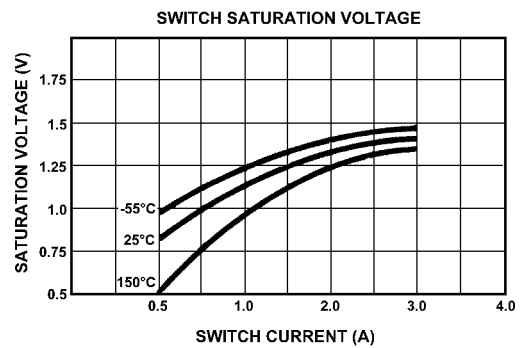
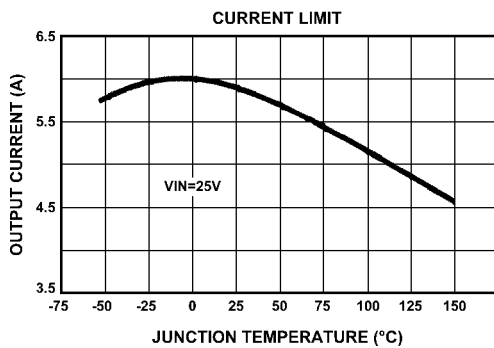
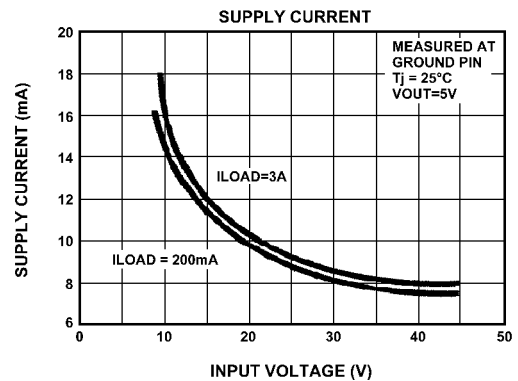
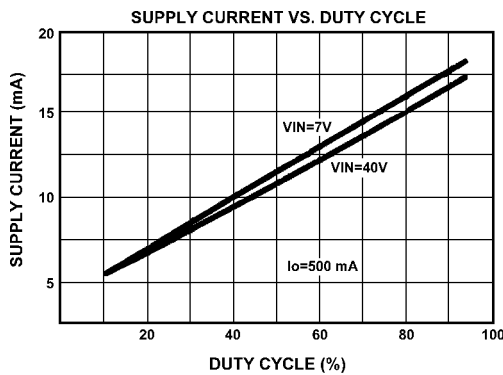
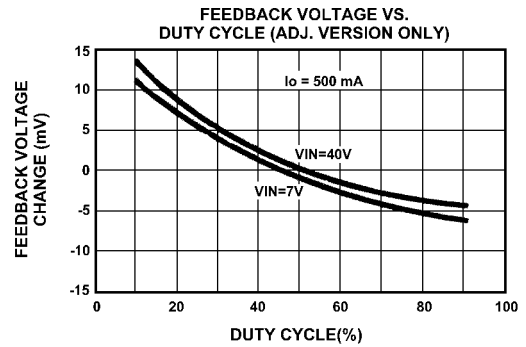
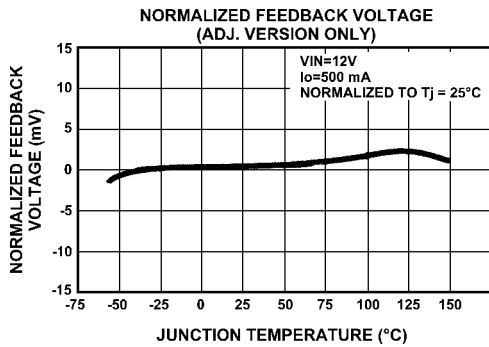
LM2576 - OPERATIONAL DATA

April 7, 1998

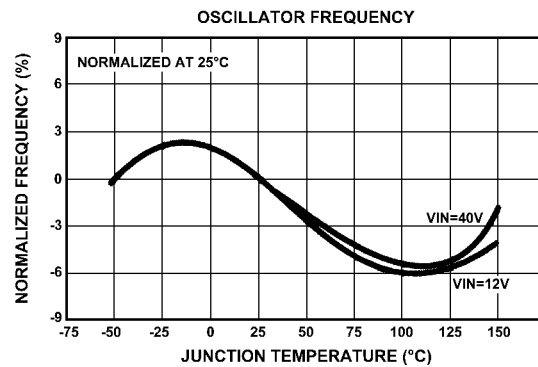
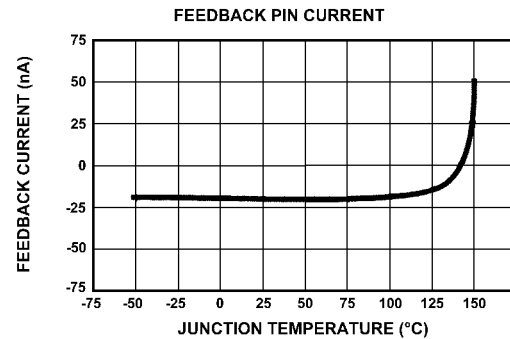
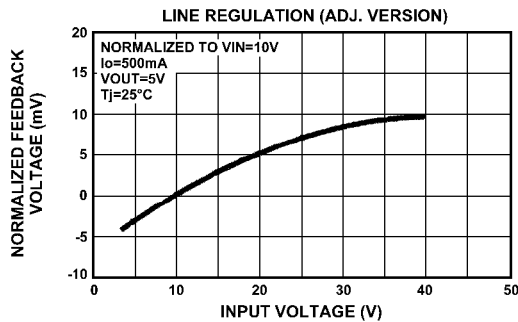
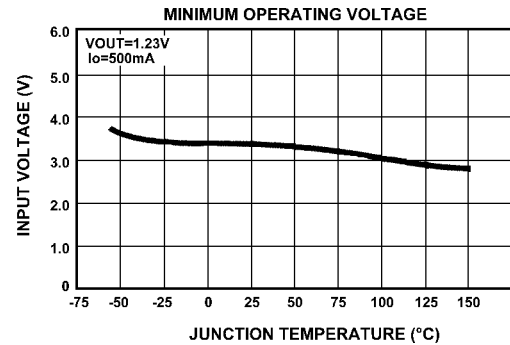
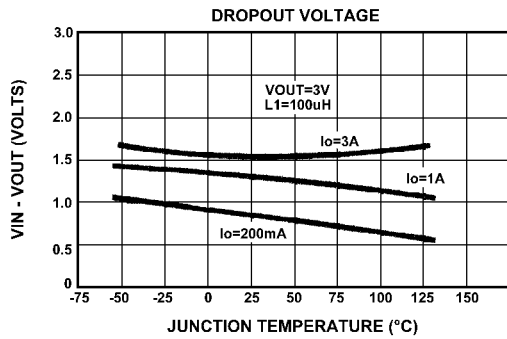
LM2576 - OPERATIONAL DATA

April 7, 1998

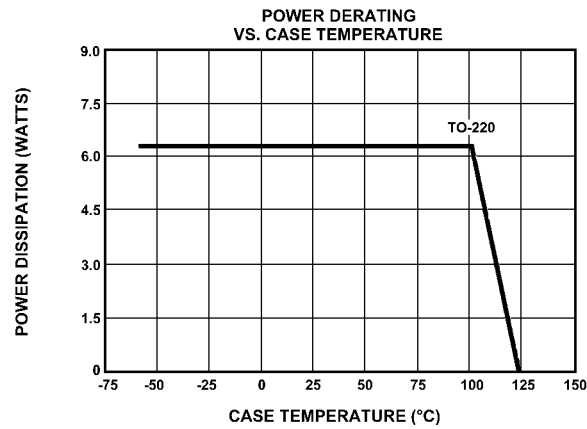
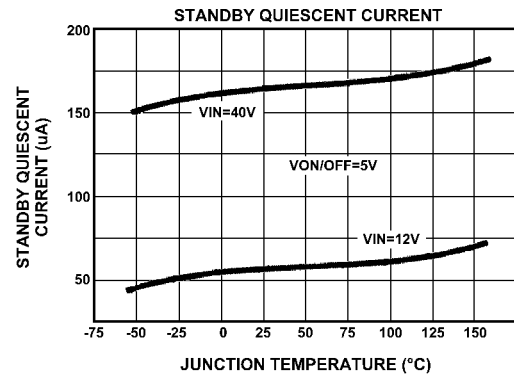
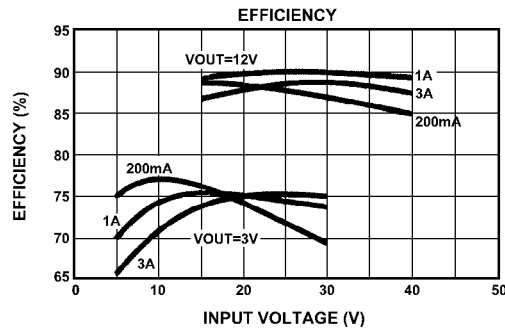
LM2576 - OPERATIONAL DATA

April 7, 1998

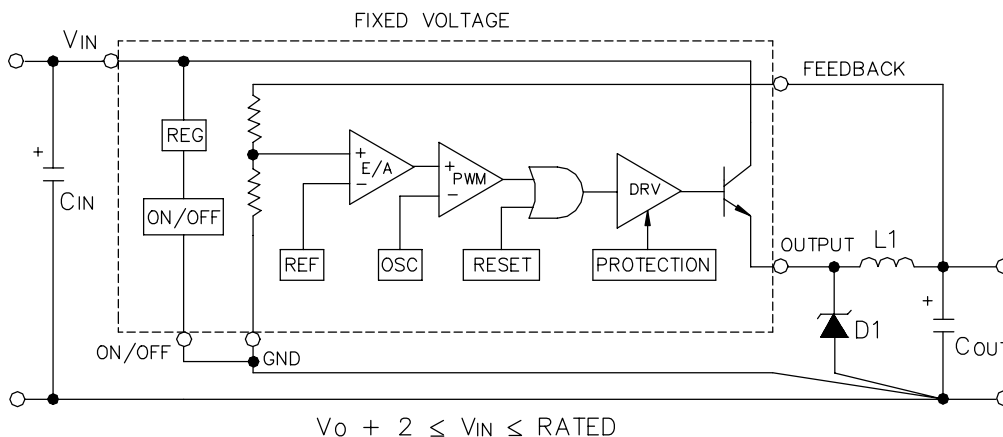
TYPICAL APPLICATION - BUCK MODE

	LM2575	LM2576
L_1	330 μ H	100 μ H
D_1	3A	7A
C_{IN}	68 μ F	120 μ F
C_{OUT}	330 μ F	1,000 μ F

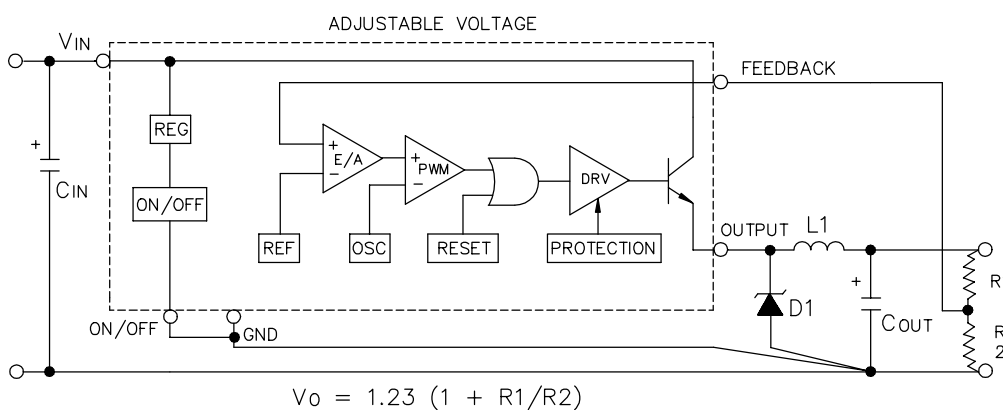

	LM2575	LM2576
L_1	330 μ H	100 μ H
D_1	3A	7A
C_{IN}	68 μ F	120 μ F
C_{OUT}	330 μ F	1,000 μ F

The above component selections will be adequate for most applications for output currents from 250mA to 3.0A (LM2576) or 150mA to 1.0A (LM2575). Applications with V_{OUT} below 5V or above 24V may require component adjustment for maximum performance; please contact factory for application assistance.

1. DEVICE SELECTION. Select an appropriate device from the "Ordering Information" guide based upon voltage option and package.

2. THERMAL CONDITIONS. Most applications will not require a heatsink for the TO-220 package. Approximate power dissipation is:

$$P = \frac{V_o I_o V_{SAT}}{V_{IN}} + 0.02 V_{IN} \frac{|V_o|}{V_{IN}}$$

3. CATCH DIODE. If the output must be capable of a sustained short, the I_F rating must be above 3A for the LM2575 and 7A for the LM2576. The use of an ultra fast diode with soft recovery characteristics or a Schottky will be adequate. The major impact on Schottky versus an ultra fast is efficiency. Schottkys will provide approximately 4% to 5% improvement for V_{OUTS} below 12V, whereas above 12V the difference will become less significant. Breakdown rating must be in excess of V_{IN} for margin.

4. INPUT CAPACITOR. The value shown will be adequate for most applications. Ripple voltage at the switching frequency is caused by the input capacitor supplying load current during the on time of the power switch. The use of a low ESR switching type capacitor will minimize ripple to an acceptable level.

April 7, 1998

5. LAYOUT. Use short connections with a central point ground to prevent improper operation caused by stray inductance and ground loops.

6. OUTPUT CAPACITOR. Ripple voltage on V_{OUT} is directly related to the value of C_{OUT} and the internal resistance ESR of C_{OUT} . Output noise can be lowered by increasing C_{OUT} or by selecting a capacitor with a lower ESR. ESR must be approximately 0.03Ω for the LM2576 or 0.07Ω for the LM2575, or above to maintain stability, otherwise raise value of C_{OUT} .

7. SWITCHING SPIKES. Switching spikes will also occur due to distributive capacitance across turns of the inductor when combined with output capacitor series inductance (ESL). Reduction to a level at or below the switching ripple can be achieved by using a post filter as shown.

SWITCHING SPIKE REDUCTION

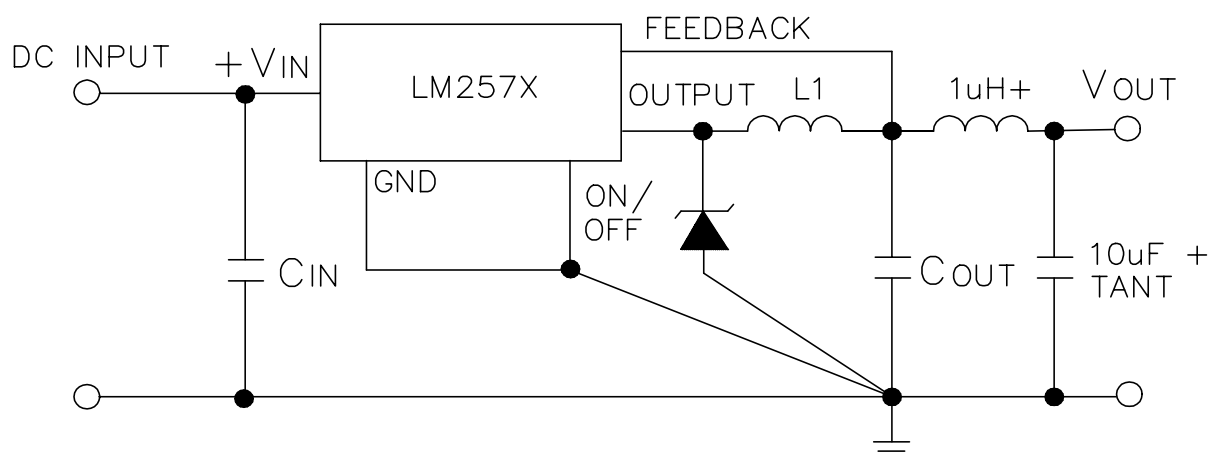

April 7, 1998

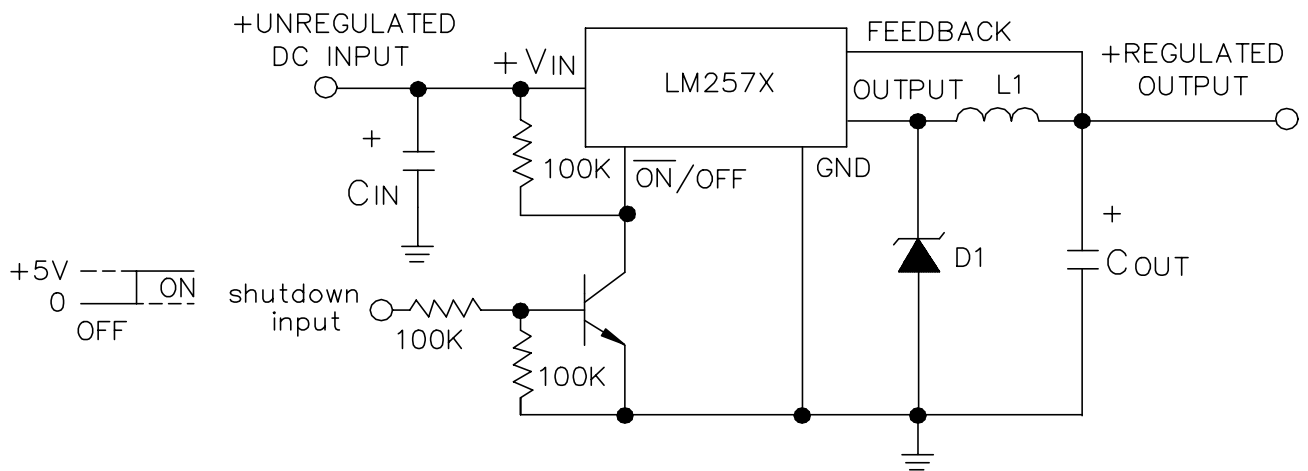
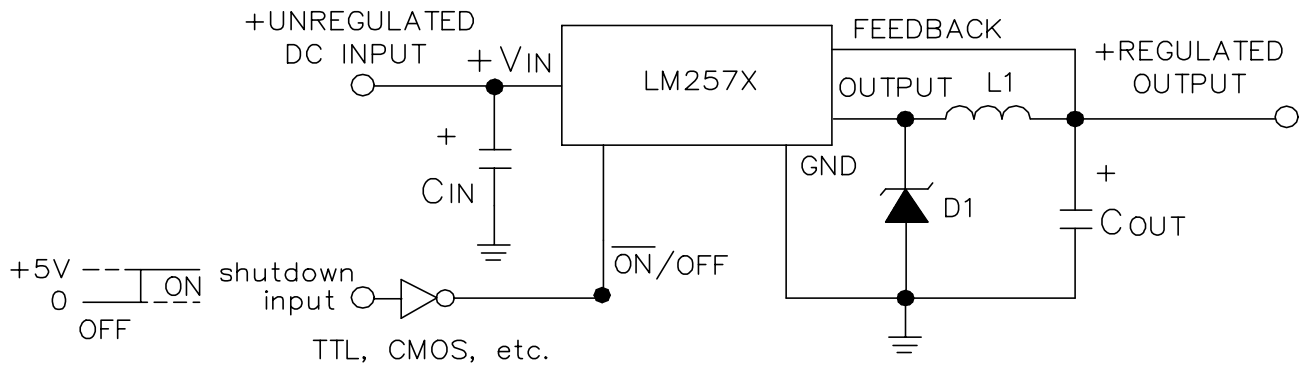
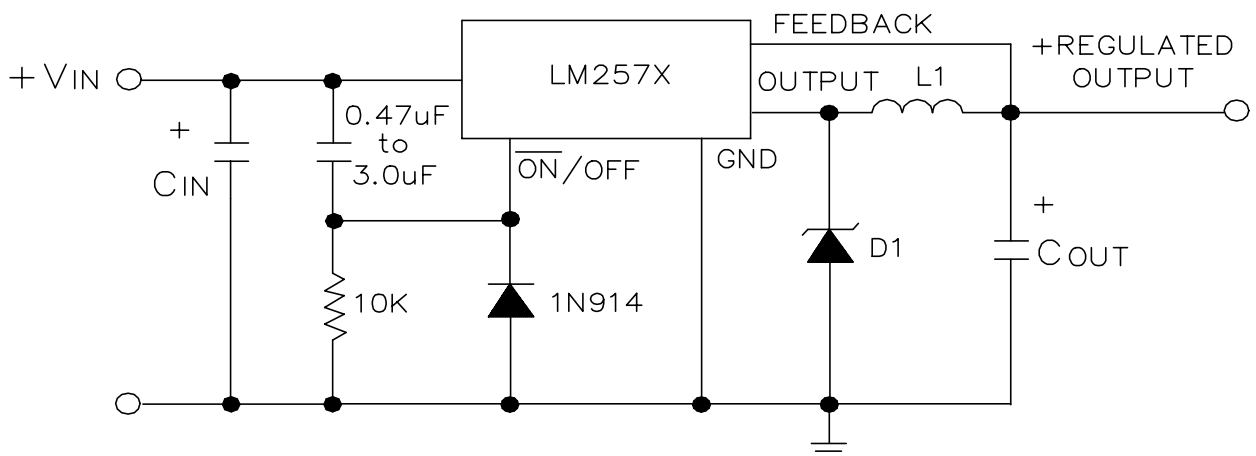
TYPICAL BUCK SHUTDOWN

TURN-ON DELAY

Circuit allows for C_{IN} to be fully charged before start-up, provides C_{IN} to supply hi-peak current instead of input supply.

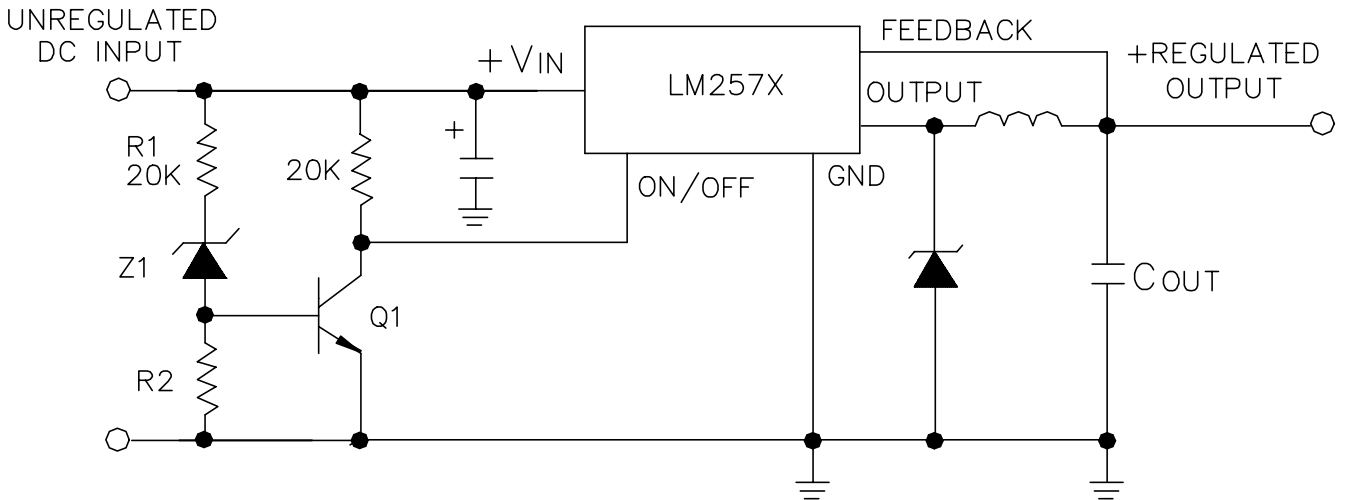
April 7, 1998

UNDER VOLTAGE LOCKOUT

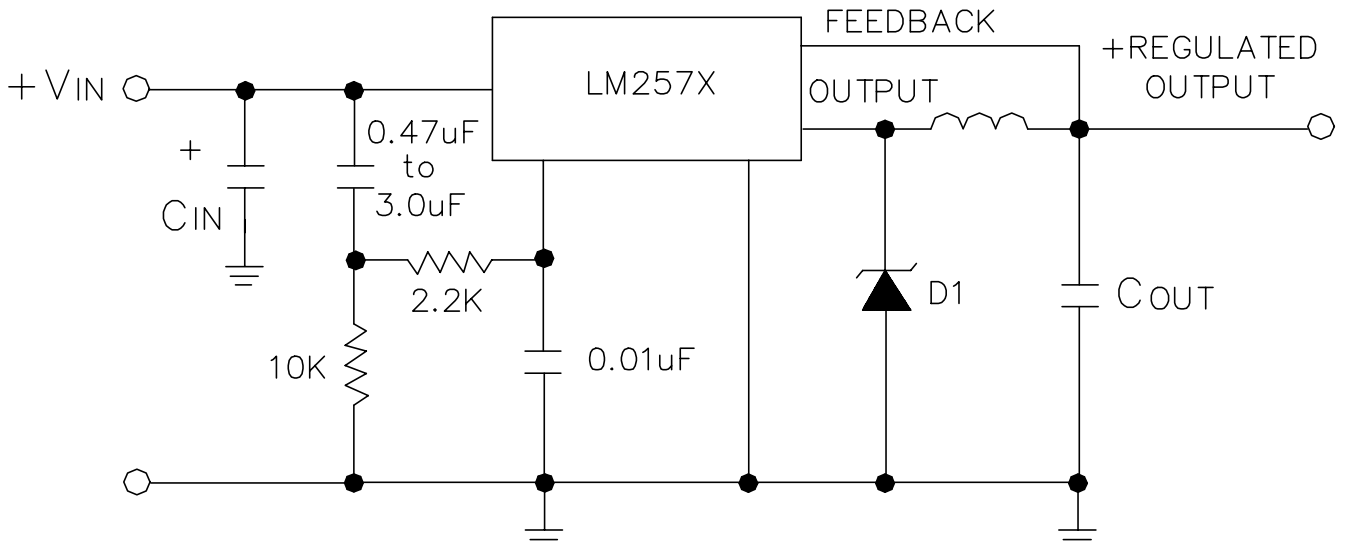
Regulator will be off until a V_{IN} set point is reached.
 $V_{IN} (ON) \cong V_Z + 3V_{BE Q1}$

TURN-ON DELAY WITH SPIKE FILTER

Spike filter reduces input noise, causing false triggering of delay.

April 7, 1998

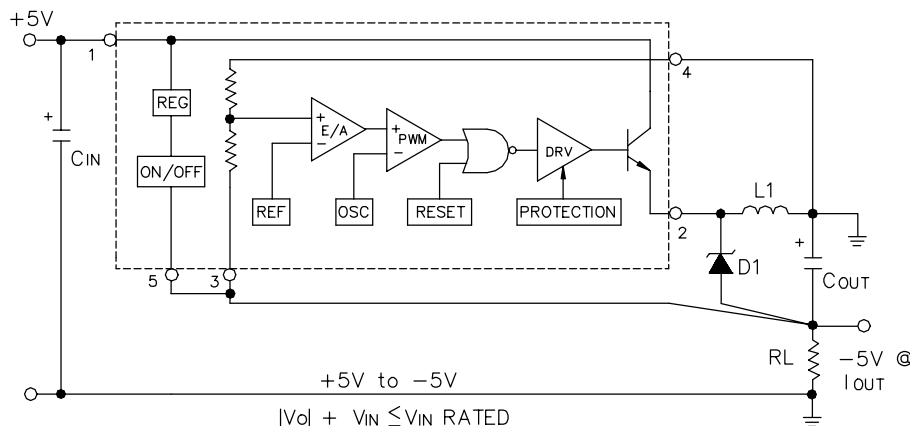
TYPICAL APPLICATION - INVERTING BUCK/BOOST

	LM2575	LM2576
C _{IN}	47μF	100μF
D1	3A	7A
L1	100μH	68μH
C _{OUT}	2,700μF	6,800μF
I _{OUT}	250mA	500mA

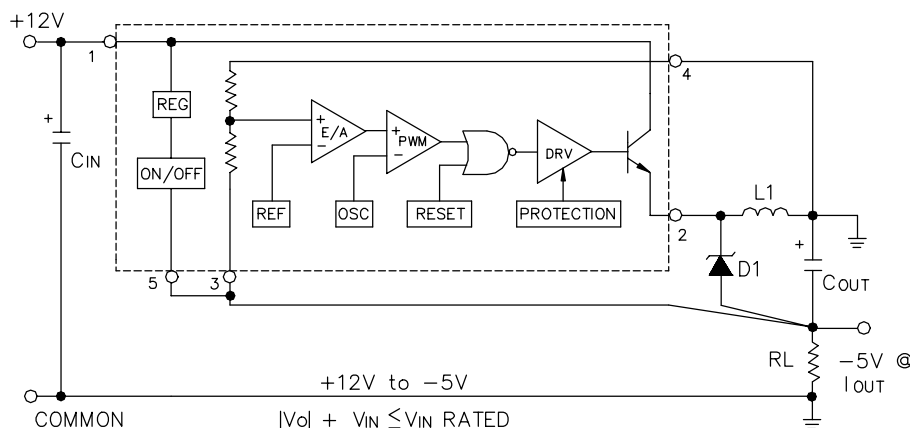

	LM2575	LM2576
C _{IN}	47μF	100μF
D1	3A	7A
L1	100μH	68μH
C _{OUT}	470μF	2,700μF
I _{OUT}	100mA	750mA

Inverting buck/boost operation is a different topology of operation than buck. This difference reduces the output current capability of the device, in that the inductor must supply all of the load current during the time the power switch is off. Maximum output current is approximately:

$$I_{OUT} \approx \frac{3.5}{2 \left(1 + \frac{|V_O|}{V_{IN}} \right)} \quad (\text{LM2576})$$

$$I_{OUT} \approx \frac{1.3}{2 \left(1 + \frac{|V_O|}{V_{IN}} \right)} \quad (\text{LM2575})$$

Component stress requirement is very similar to the buck with a few exceptions:

- catch diode breakdown V_{BR} must be greater than $V_{IN} + |V_{OUT}|$
- input capacitor is larger due to the increased peak current during switch turn on. Power dissipation is approximately:

$$P_D \approx \left(\frac{|V_O|}{|V_O| + V_{IN}} \right) I_O \left(1 + \frac{|V_O|}{V_{IN}} \right) V_{SAT} + 0.02 V_{IN} \frac{|V_O|}{V_{IN}}$$

Please contact factory for additional assistance when using the buck/boost topology.

April 7, 1998

INVERTING BUCK/BOOST SHUTDOWN

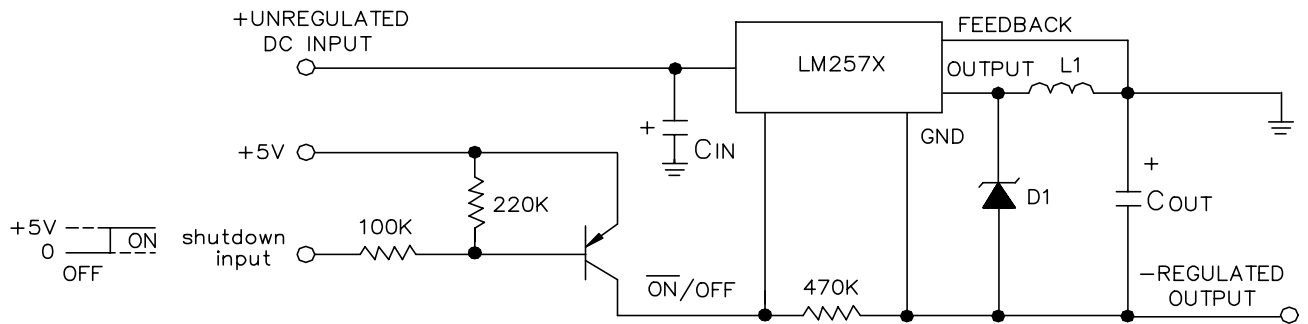
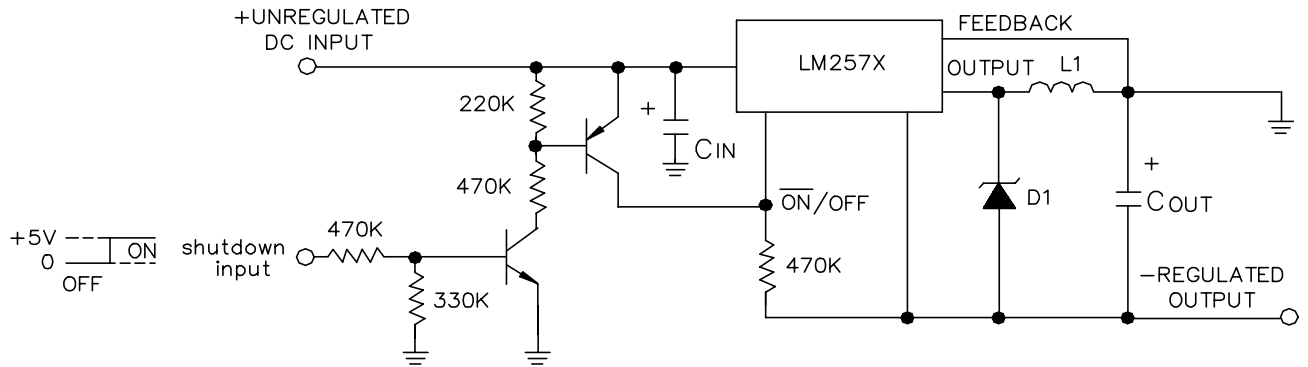

April 7, 1998

SUPPORT COMPONENTS INFORMATION

PRE-WOUND INDUCTORS:

Hurricane Electronics Lab
P.O. Box 1280
Hurricane Industrial Park
Hurricane, UT 84737
(801) 635-2003

CORE SOURCE:

Micro Metals, Inc.
1190 N. Hawk Circle
Anaheim, CA 92807
(714) 630-7420

CAPACITORS:

VPR Series
Mallory Capacitor Co.
4760 Kentucky Avenue
Indianapolis, IN 46241
(317) 856-3731

511D & 673 Series
Sprague Electric Co.
North Adams, MA
(413) 664-4411

HFQ, HFZ Series
Panasonic Industrial Co.
2 Panasonic Way
Secaucus, NJ 07094
(201) 392-6142

PF, PL Series
Nichicon Corp.
927 E. State Pkwy.
Schaumburg, IL 60195
(708) 843-7600

LXF Series
United Chemi-con
9801 West Higgins Road
Rosemont, IL 60018
(708) 696-2000

HEAT SINKS:

AAVID Engineering Co.
P.O.Box 400
One Kool Path
Laconia, NH 03247
(603) 528-3400

Thermalloy, Inc.
2021 W. Valley View Lane
Dallas, TX 76381
(214) 243-4321

DIODES - CATCH:

Ultra Fast/Soft Recovery
Semtech Corporation
652 Mitchell Road
Newbury Park, CA 91320
(805) 498-2111

DIODES - SCHOTTKY:

Fuji/Collmer Semiconductor
14368 Proton Road
Dallas, TX 76244
(800) 527-0521

Micro Quality
1000 N. Shiloh
Garland, TX 76046
(214) 272-7811

April 7, 1998

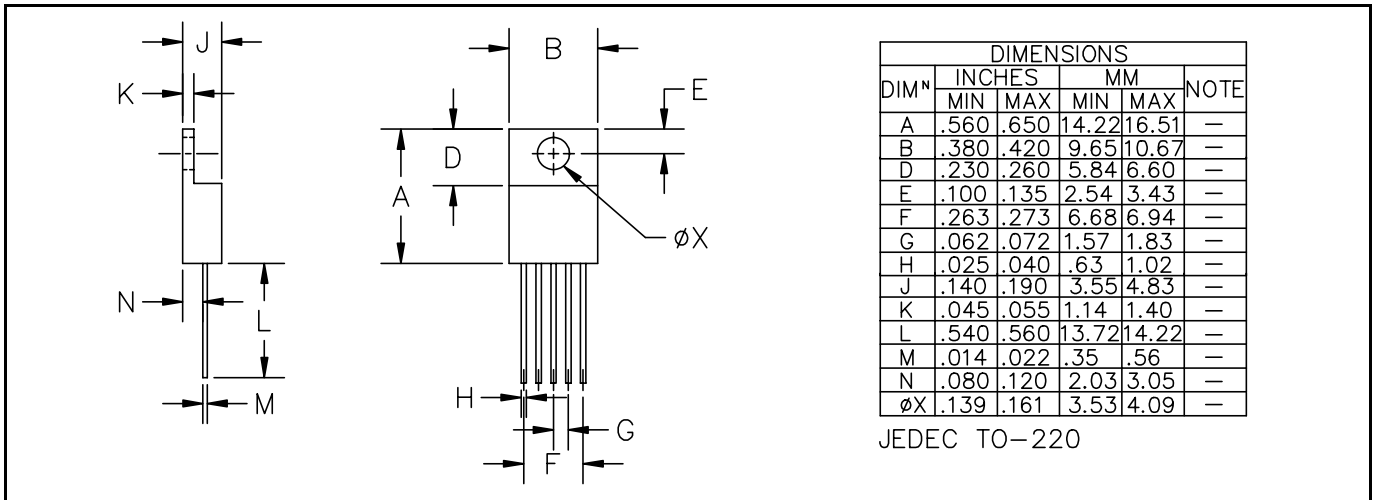
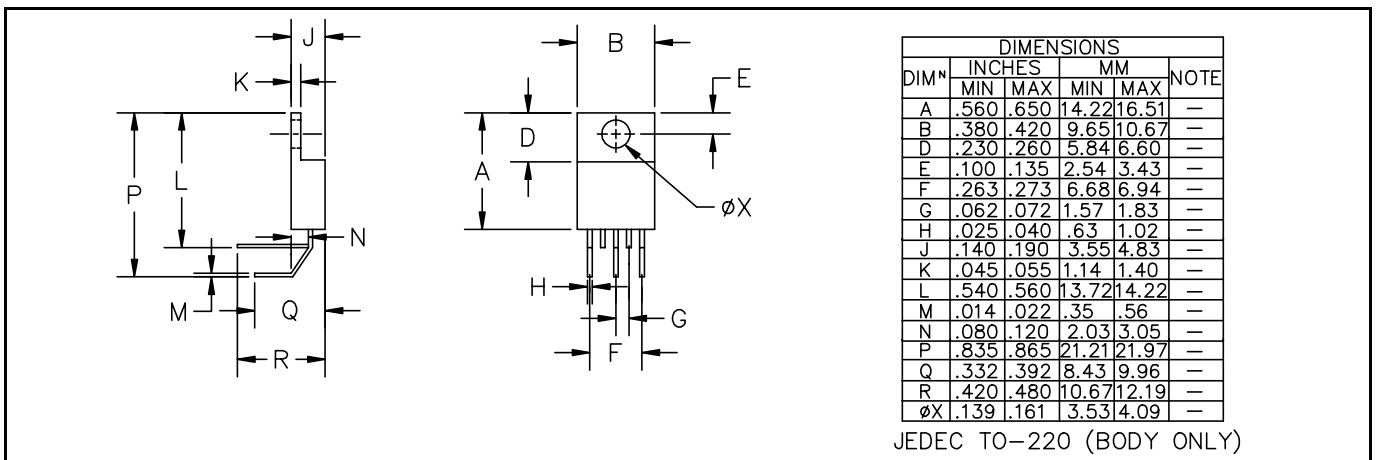
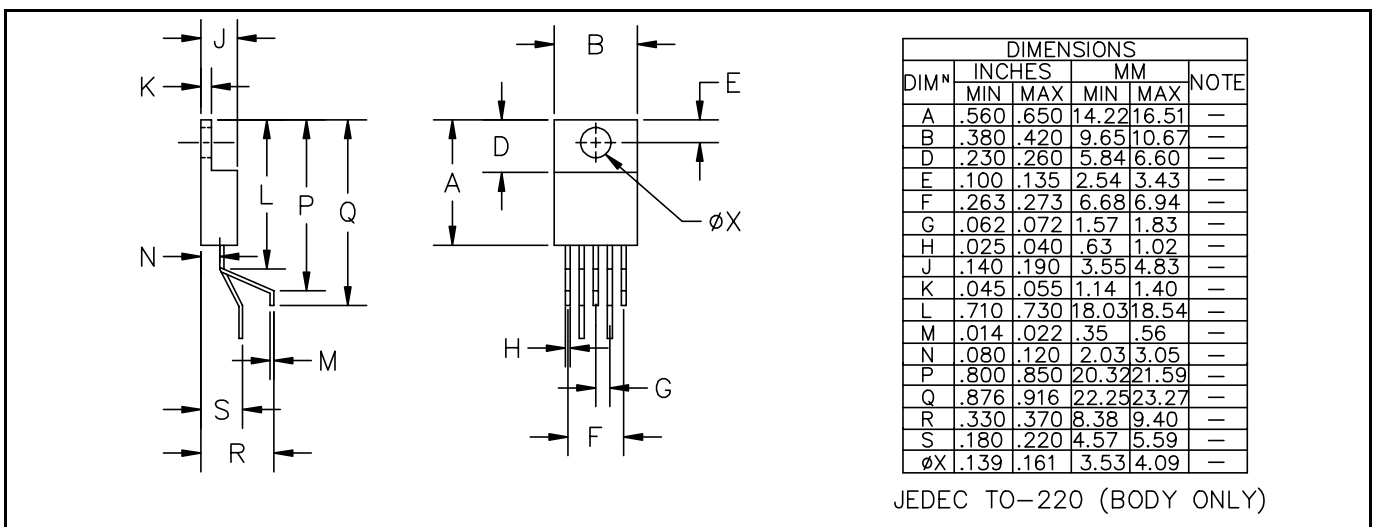
OUTLINE - TO-220 (T-XX Option)

OUTLINE - TO-220 (T-XX-H Option)

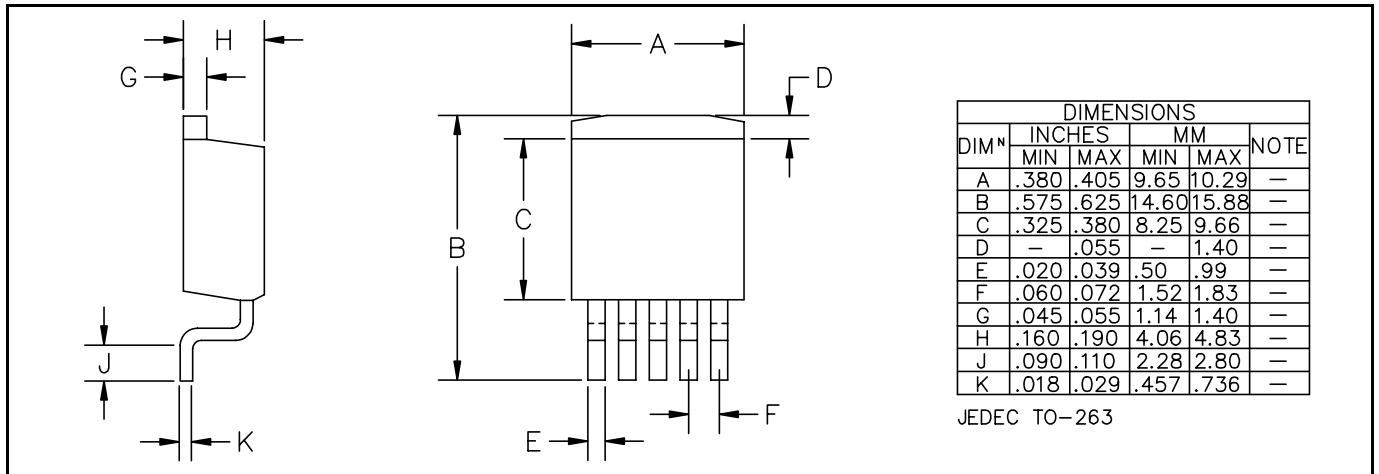
OUTLINE - TO-220 (T-XX-V Option)

April 7, 1998

OUTLINE - TO-263

PIN CONFIGURATIONS
