

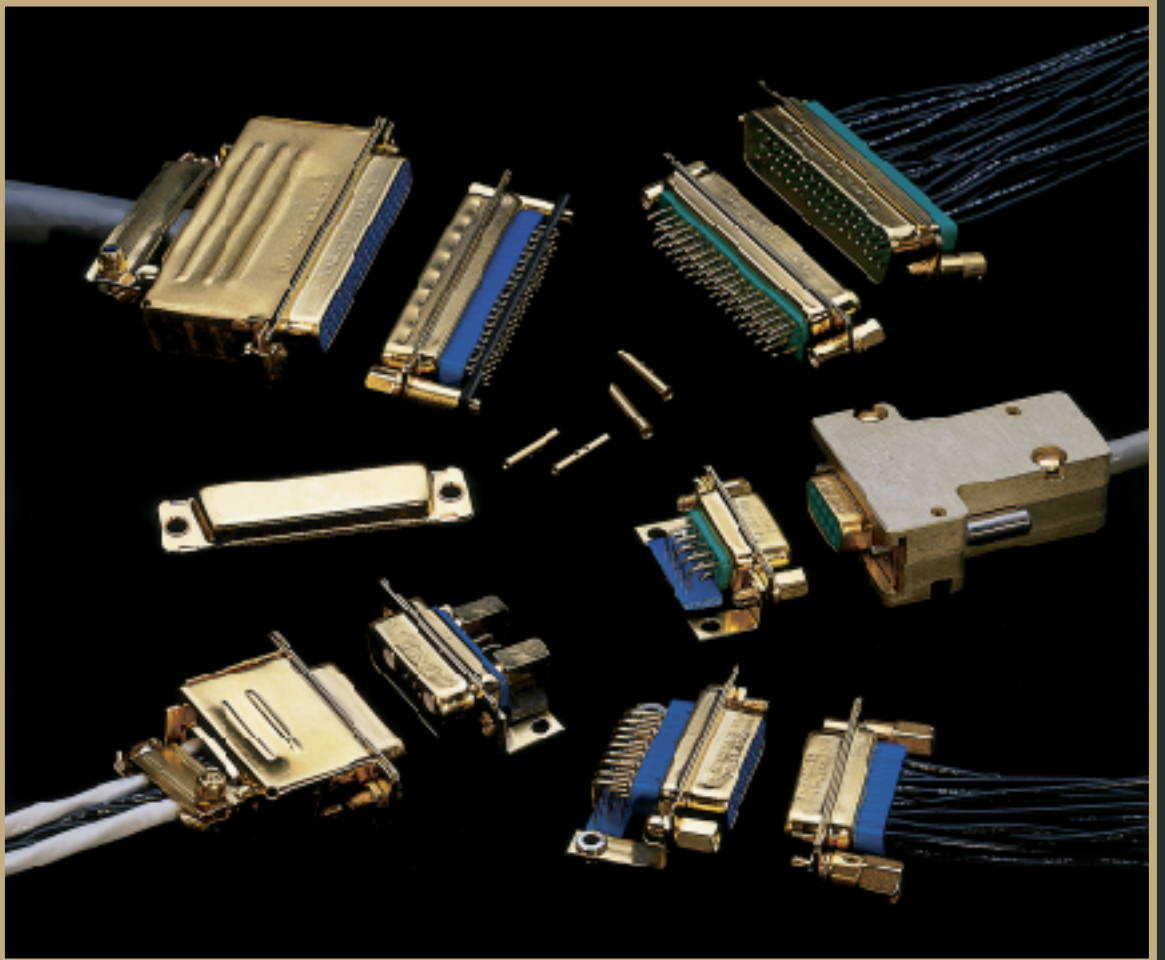

POSITRONIC INDUSTRIES



# SPACE APPLICATION SUBMINIATURE-D CONNECTORS



GSFC S-311-P-4  
GSFC S-311-P-10  
MIL-DTL-24308



## Maximum Torque Values for 4-40 UNC Threads

MATERIAL	TORQUE		
	Nm	in-lb	in-oz
Phos. Bronze	0.90	8.0	128
Brass	0.68	6.0	96
Aluminum	0.45	4.0	64
Nylon	0.11	1.0	16

These torque values are applicable for threads only and do not apply to hardware assemblies. These torque values are approximate and should not be accepted as accurate limits. Indeterminant factors in specific applications preclude the publication of accurate torque values for universal use.

### Unless otherwise specified, dimensional tolerances are:

- 1)  $\pm 0.001$  inches (0.03 mm) for male contact mating diameters.
- 2)  $\pm 0.003$  inches (0.08 mm) for contact termination diameters.
- 3)  $\pm 0.005$  inches (0.13 mm) for all other diameters.
- 4)  $\pm 0.015$  inches (0.38 mm) for all other dimensions.

CATALOG NUMBER:  
**C-005 REV. NC**

PUBLISHED IN THE UNITED STATES OF AMERICA

Positronic Industries, Inc. believes the data contained herein to be reliable. Since the technical information is given free of charge, the User employs such information at his own discretion and risk. Positronic Industries, Inc. assumes no responsibility for results obtained or damages incurred from use of such information in whole or in part.

**Positronic Industries' FEDERAL SUPPLY CODE FOR MANUFACTURERS is Number 28198.**

**This catalog should be accompanied by a copy of Positronic Industries' Subminiature-D Connector and Cable Accessory Catalog.**

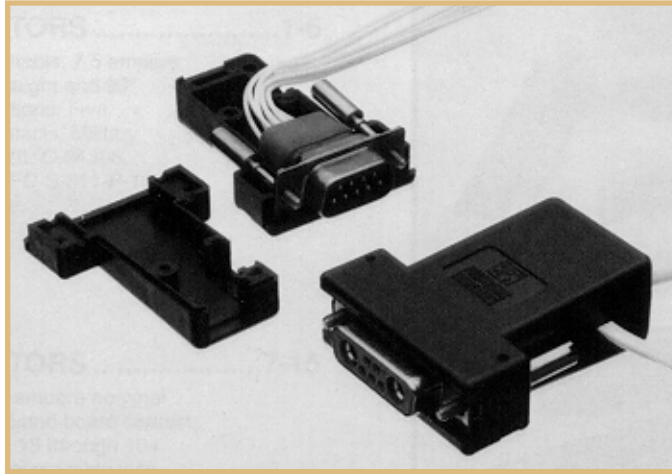

**Additional special application Subminiature-D Connector catalogs are available upon request. Contact our Factory Sales Office or your District Sales Manager for copies of these catalogs:**

**INDUSTRIAL & MILITARY APPLICATION  
SUBMINIATURE-D CONNECTORS**

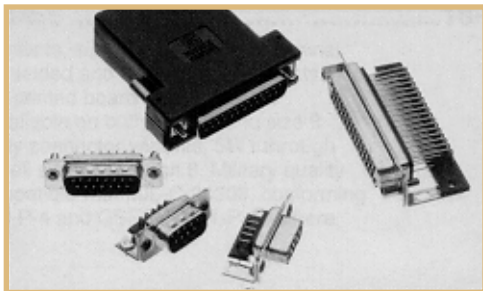

**ENVIRONMENTAL-D CONNECTORS**



**COMBO-D CONNECTORS**

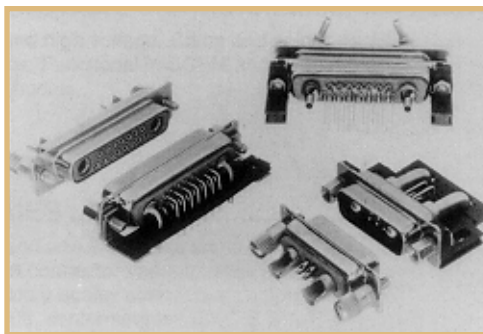

**DUAL-PORT CONNECTORS**

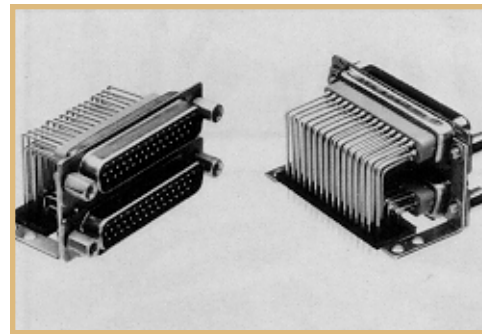

**FILTER-D CONNECTORS**

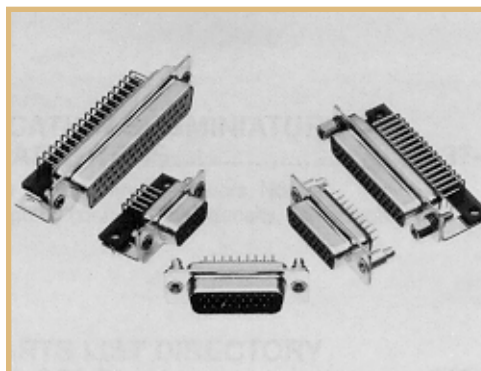

# TABLE OF CONTENTS

## SPACE NORMAL DENSITY SUBMINIATURE-D CONNECTORS .....1 - 7

SND Series. Removable or fixed contacts, 7.5 ampere nominal rating. Crimp, solder and straight and 90° printed board mount contact terminations. Five connector variants, 9 through 50 contacts. Military quality connectors compatible with MIL-DTL-24308, conforming to GSFC-S-311-P-4 and GSFC-S-311-P-10 where applicable.



## SPACE DENS-D SUBMINIATURE-D CONNECTORS .....8 - 16

SDD Series. Removable or fixed contacts, 5 ampere nominal rating. Crimp and straight and 90° printed board contact terminations. Six connector variants, 15 through 104 contacts. Military quality connectors compatible with MIL-DTL-24308, conforming to GSFC-S-311-P-4 where applicable.

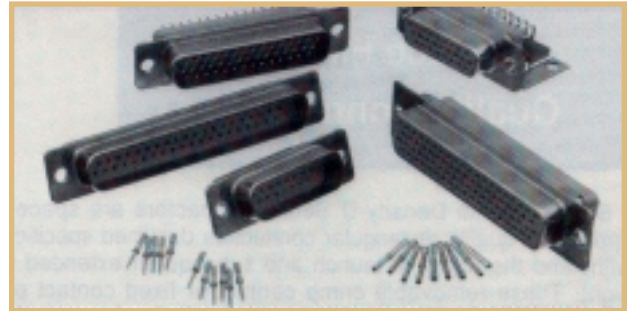

## SPACE COMBINATION CONTACT SUBMINIATURE-D CONNECTORS .....17 - 43

### SCBM SERIES .....17 - 35

Fixed signal contacts, Size 20, 7.5 ampere nominal rating. Size 8 shielded and power contacts. Solder cup and printed board mount contact terminations available on both Size 20 and Size 8 contacts. Twenty connector variants, 5W1 through 46W4, using shell sizes 1 through 6. Military quality connectors compatible with MIL-DTL-24308, conforming to GSFC-S-311-P-4 and GSFC-S-311-P-10 where applicable.

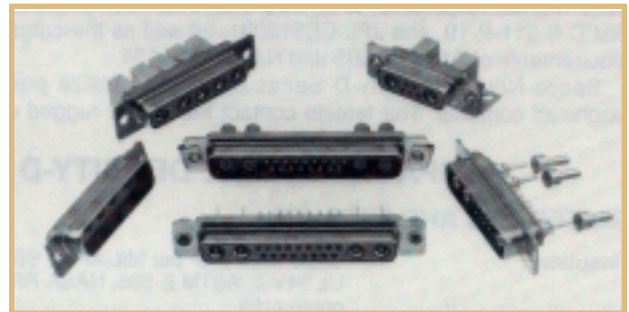

### SIZE 8 REMOVABLE CONTACTS .....27 - 34

Shielded and high voltage and power crimp and solder terminations. Functional in SCBM and SCBC connector bodies.

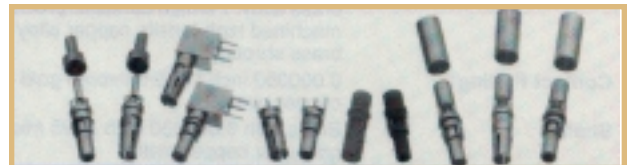

### SCBC SERIES .....32 - 43

Size 20 signal and Size 8 shielded and power removable contacts. Eleven connector variants, shell sizes 1 through 6. Military quality connectors compatible with MIL-DTL-24308, conforming to GSFC-S-311-P-4 where applicable.

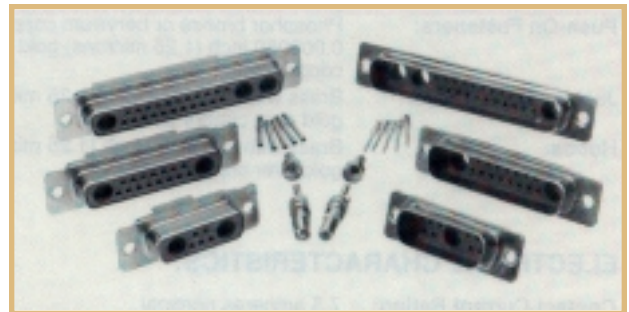

## SPACE APPLICATION SUBMINIATURE-D CONNECTOR SAVERS .....44 - 47

SAD, SADD and SACBM Series connector savers. Normal density, 9 through 50 contacts. High density, 15 through 104 contacts. Combination size 20 contact/ Size 8 contact connectors using shell sizes 1 through 6.



## ACCESSORIES .....48 - 54

## QUALIFIED PARTS LIST DIRECTORY PER GSFC-311-QPLD .....55 - 57

### CRIMP CONTACTS CLOSED CRIMP BARREL

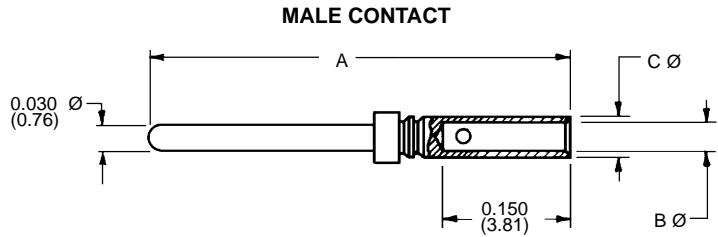
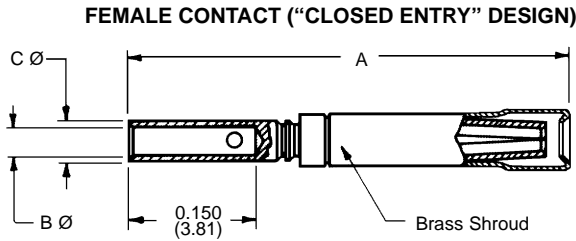

Crimp contacts may be supplied kitted with connector or ordered separately.

PART NUMBER	WIRE SIZE AWG/(mm <sup>2</sup> )	A	B Ø	C Ø
FC8022D-50-1202.0	22 / 24 / 26 / 28 / 30 (0.3/0.25/0.12/0.08/0.05)	0.518 (13.16)	0.035 (0.89)	0.047 (1.19)

PART NUMBER	WIRE SIZE AWG/(mm <sup>2</sup> )	A	B Ø	C Ø
MC8022D-50	22 / 24 / 26 / 28 / 30 (0.3/0.25/0.12/0.08/0.05)	0.531 (13.49)	0.035 (0.89)	0.047 (1.19)

**Material:** Leaded nickel copper.  
**Plating:** 0.000050 inch (1.25 μ) gold over copper.

**Material:** Brass.  
**Plating:** 0.000050 inch (1.25 μ) gold over copper.

### REELS FOR AUTOMATIC FEED PNEUMATIC CRIMP TOOLS

Contacts may be supplied in plastic carriers, packaged in reels holding 2,000 contacts for use with the automatic feed pneumatic crimp tools, catalog part number 9550-1. The same type carrier is used for both male and female contacts.

All male and female crimp contacts can be ordered in reels by adding letter "R" after the contact part number, such as MC8022DR-50 for a male contact and FC8022DR-50-1202.0 for female contact.

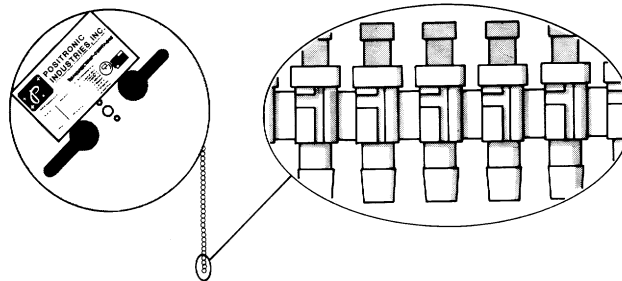

Enlarged section of plastic contact carriers

For SDD crimping information and crimp tools, see pages 13, 14, and 16.



### STRAIGHT PRINTED BOARD MOUNT CONTACTS

FEMALE CONTACT ("CLOSED ENTRY" DESIGN)

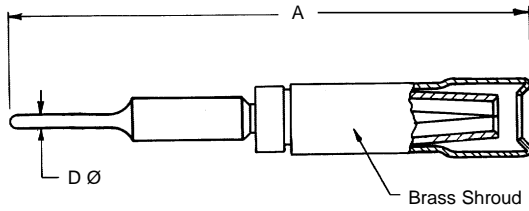

MALE CONTACT

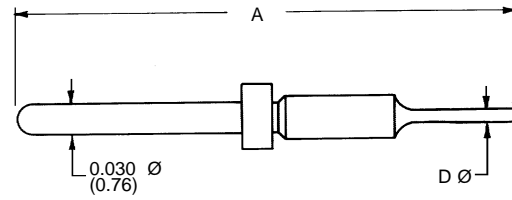

Straight printed board mount contacts are supplied in the connector.

CODE NUMBER	L	D Ø	A
3	0.150 (3.81)	0.020 (0.51)	0.725 (18.42)
32	0.300 (7.62)	0.020 (0.51)	0.865 (21.97)

For straight printed board mount contacts, specify Code Number in Step 4 of the Ordering Information.

CODE NUMBER	L	D Ø	A
3	0.150 (3.81)	0.020 (0.51)	0.737 (18.72)
32	0.300 (7.62)	0.020 (0.51)	0.877 (22.28)

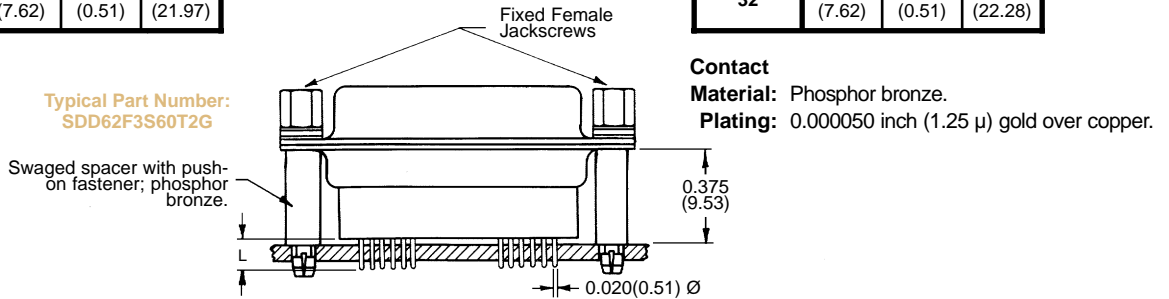

### 90° PRINTED BOARD MOUNT CONNECTOR

#### CODE 4, 0.450(11.43) CONTACT EXTENSION

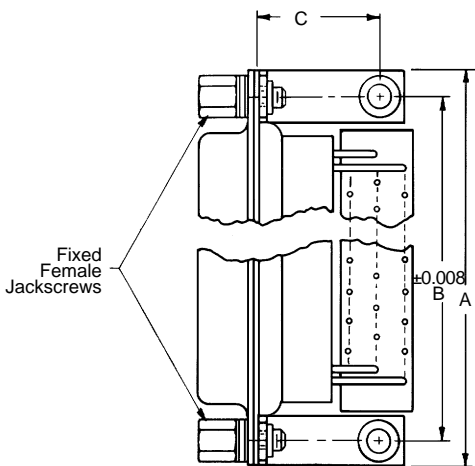

SDD004R7000 0.450(11.43) CONTACT EXTENSION				
PART NUMBER	A	B	C	D
SDD1504R7000	1.204 (30.58)	0.984 (24.99)	0.528 (13.41)	0.450 (11.43)
SDD2604R7000	1.532 (38.91)	1.312 (33.32)	0.528 (13.41)	0.450 (11.43)
SDD4404R7000	2.072 (52.63)	1.852 (47.04)	0.528 (13.41)	0.450 (11.43)
SDD6204R7000	2.720 (69.09)	2.500 (63.50)	0.528 (13.41)	0.450 (11.43)
SDD7804R7000	2.626 (66.70)	2.406 (61.11)	0.573 (14.55)	0.450 (11.43)
SDD10404R7000	2.720 (69.09)	2.500 (63.50)	0.614 (15.60)	0.450 (11.43)

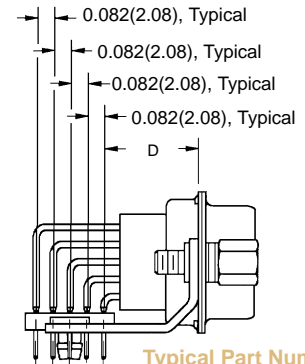

Typical Part Number: SDD104M4R7NT2G

Specify Code 4 in Step 4 of the Ordering Information.

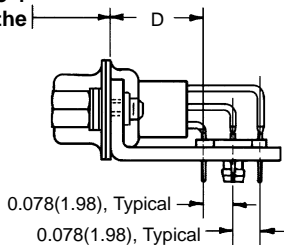

Typical Part Number: SDD44F4R7NT2G

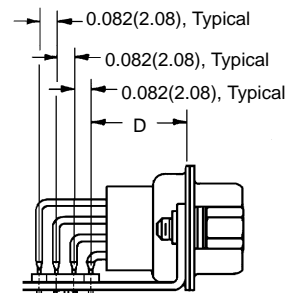
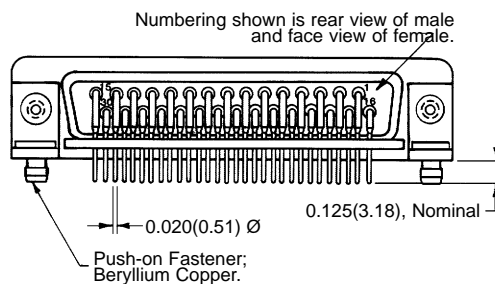

Typical Part Number: SDD78M4R7NT2G

DIMENSIONS ARE IN INCHES (MILLIMETERS). ALL DIMENSIONS ARE SUBJECT TO CHANGE.

### 90° AND STRAIGHT PRINTED BOARD CONTACT HOLE PATTERN

Mount connector with mating face positioned to follow direction of arrows.

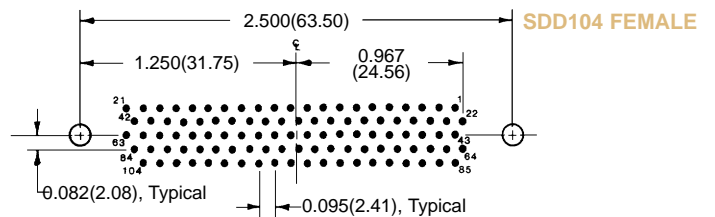
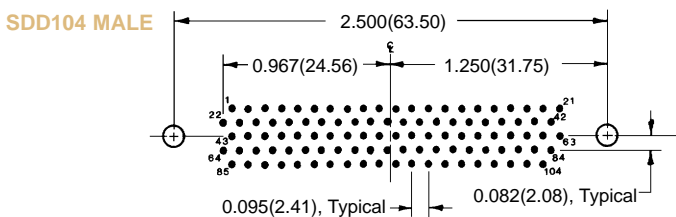
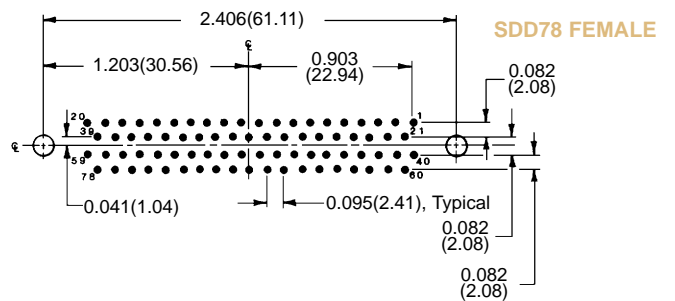
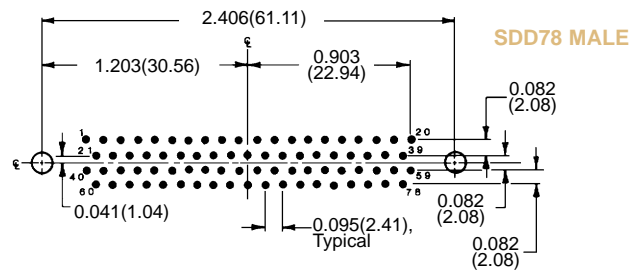
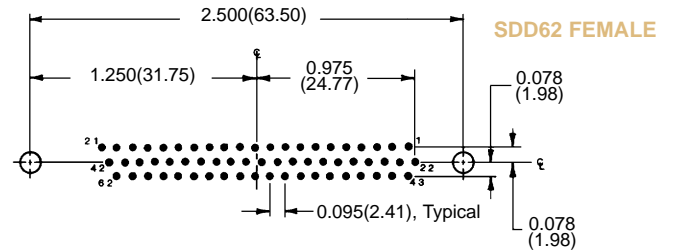
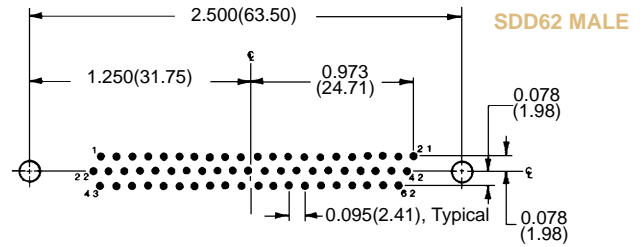
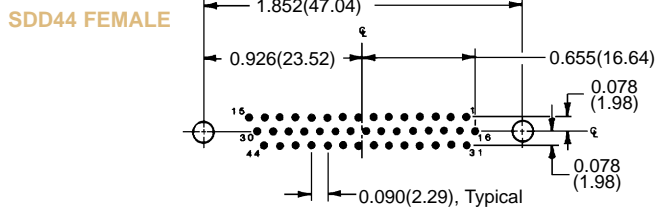
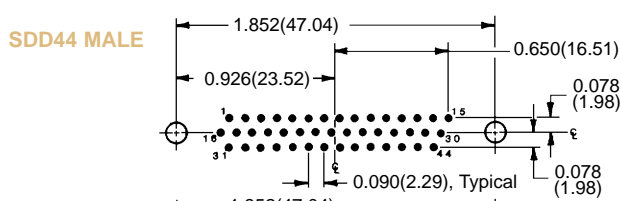
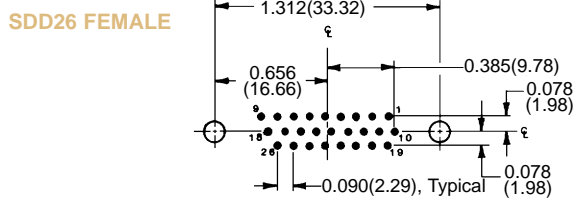
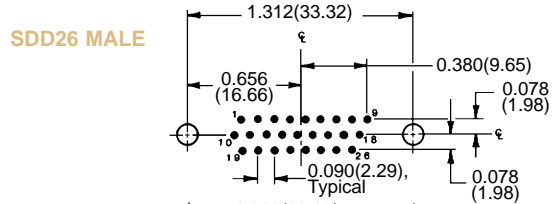
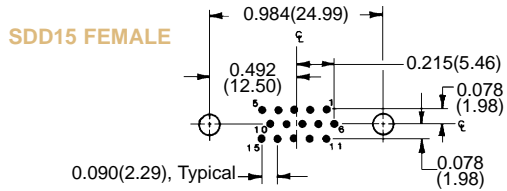
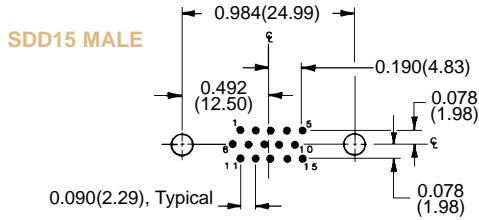

Suggest 0.035(0.89) Ø hole for contact termination positions.

Suggest 0.123 ±0.003(3.12) Ø hole for mounting connector with push-on fasteners.

DIMENSIONS ARE IN INCHES (MILLIMETERS).  
ALL DIMENSIONS ARE SUBJECT TO CHANGE.

### CRIMPING INFORMATION FOR SDD SERIES CRIMP CONTACTS USE INDICATED POSITRONIC TOOLS FOR BEST RESULTS

**Step 1: Strip wire to indicated length.**

- Take Care Not To:**
- Damage or remove strands.
  - Untwist or overtwist strands.
  - Leave insulation particles on strands.
  - Damage insulation.

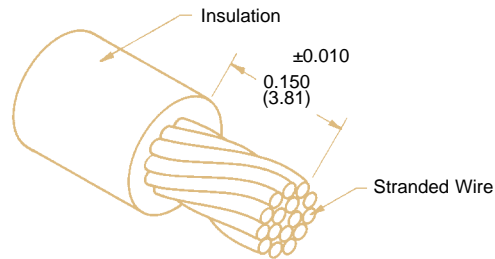

**Correctly Stripped Wire**

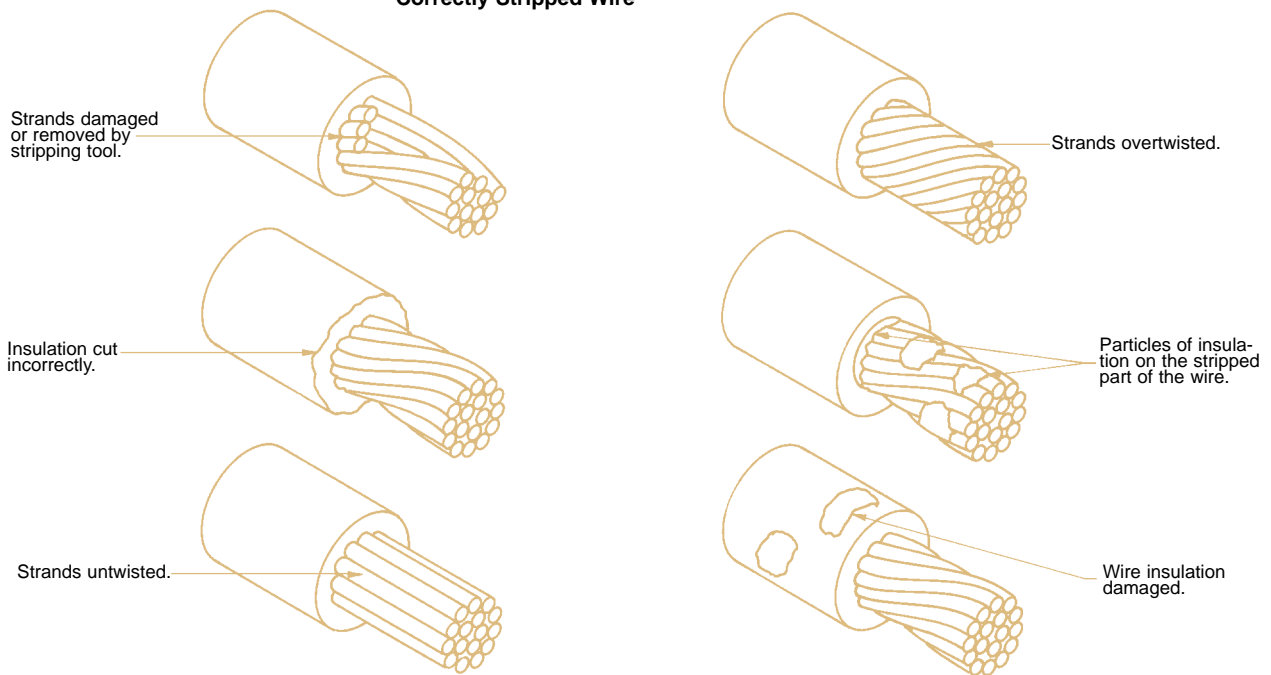

**Examples of Stripping Faults**

**Step 2: Crimp wire to contact.**

- For Hand Crimp Tool:**
- Place contact into crimping tool.
  - Insert wire into contact.
  - Center contact by slowly closing the crimping tool until the crimp indenters make contact with the crimp barrel.
  - Complete the cycle of the crimping tool in one smooth motion.
  - Remove the crimped contact.

- For Automatic Feed Pneumatic Crimp Tool:**
- Insert the wire into the contact, positioned in the crimp tool by the plastic carrier.
  - Depress the activating device of the crimping tool to start the crimping cycle.
  - Remove the crimped contact.



### CRIMPING INFORMATION FOR SDD SERIES CRIMP CONTACTS

#### Step 3: Inspect the crimp.

- For All Tools:
- Strands to be visible through the inspection hole.
  - Strands not to be visible beyond the insulation support.
  - Crimped contact to meet recommended conductor tensile force shown in chart.
  - Check for peeled gold and bent contacts.

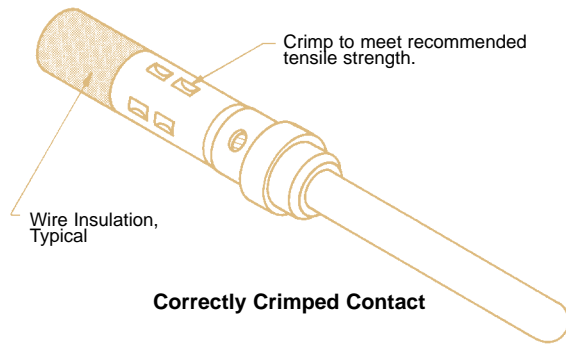

Correctly Crimped Contact

#### Cross Section of Correctly Crimped Contact

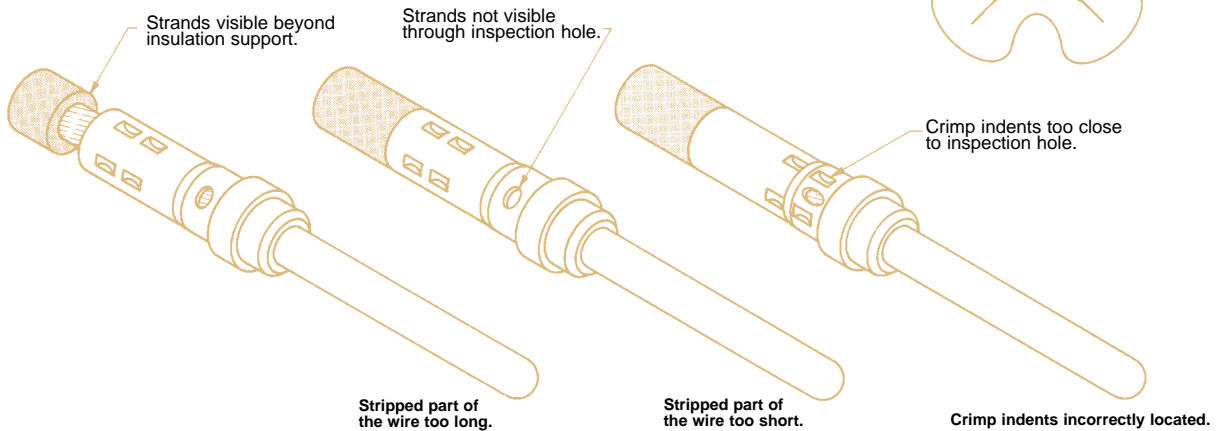
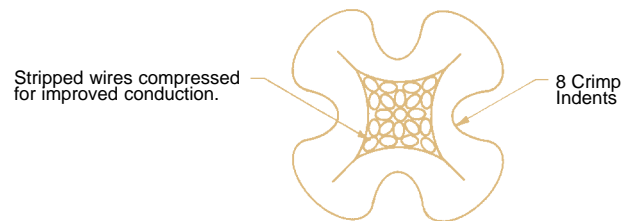

Examples of Crimping Faults

#### Positronic Recommended Conductor Tensile Strength

WIRE SIZE AWG/(mm <sup>2</sup> )	AXIAL LOAD POUNDS/(N)
$\frac{22}{(0.3)}$	$\frac{12}{(53)}$
$\frac{24}{(0.25)}$	$\frac{8}{(36)}$
$\frac{26}{(0.12)}$	$\frac{5}{(22)}$
$\frac{28}{(0.08)}$	$\frac{3}{(13)}$
$\frac{30}{(0.05)}$	$\frac{1.5}{(4.4)}$

Conductor tensile strength values are derived using silver tin-plated copper wires.

Values may change depending upon what type of wire is used.

#### Positronic Recommended Tools

CRIMP TOOLS	POSITIONERS FOR FC8022D-50-1202.2	POSITIONERS FOR MC8022D-50
9507, HAND CRIMP TOOL	9502-3	9502-4
9550-1, AUTOMATIC FEED, PNEUMATIC STRIP AND CRIMP TOOL	Supplied in reels.	Supplied in reels.

See page 16 for contact crimping tool information.

DIMENSIONS ARE IN INCHES (MILLIMETERS).  
ALL DIMENSIONS ARE SUBJECT TO CHANGE.

### ORDERING INFORMATION - CODE NUMBERING SYSTEM

Specify the complete connector by following Steps 1 through 9.  
Insert "0" when a step is not used.

STEP	1	2	3	4	5	6	7	8	9
	SDD	62	F	4	R7	N	T6	G	

#### STEP 1 - Basic Series

SDD Series

#### STEP 2 - SDD Series Connector Variants

15, 26, 44, 62, 78, 104

#### STEP 3 - Connector Gender

M -Male  
F -Female

#### STEP 4 - Contact Termination Type

- 0 - Ordered without contacts.
- 1 - Crimp, 22 AWG - 30 AWG (0.3 mm<sup>2</sup> - 0.05 mm<sup>2</sup>).
- 3 - Solder, Straight Printed Board Mount with 0.150(3.81) Tail Length.
- 32 - Solder, Straight Printed Board Mount with 0.300(7.62) Tail Length.
- 4 - Solder, 90° Printed Board Mount with 0.450(11.43) Contact Extension.

#### \* STEP 5 - Mounting Style

- 0 - Mounting Hole, 0.120(3.05) Ø.
- B3 - Bracket, Mounting, 90° Metal with Cross Bar.
- F - Float Mounts, Universal.
- P - Threaded Post, Brass, 0.375(9.53) Length.
- R2 - Bracket, Mounting, 90° Metal, Swaged to Connector with 4-40 Thread Fixed Female Jackscrews with Cross Bar.
- R6 - Bracket, Mounting, 90° Metal, Swaged to Connector with 0.120 (3.05) Ø Mounting Hole with Cross Bar.
- R7 - Bracket, Mounting, 90° Metal, Swaged to Connector with 4-40 Threads with Cross Bar.
- R8 - Bracket, Mounting, 90° Metal, Swaged to Connector with 4-40 Locknut with Cross Bar.
- S - Swaged Spacer, 4-40 Threads, 0.375(9.53) Length.
- S2 - Swaged Spacer, 4-40 Threads, 0.125(3.18) Length.
- S5 - Swaged Locknut, 4-40 Threads.
- S6 - Swaged Spacer with Push-on Fastener, 4-40 Threads, 0.375(9.53) Length.

#### STEP 9 - Special Options

Consult Sales Department.

#### STEP 8 - Shell Options

- G - Gold over Copper Plate.
- D - Gold over Copper Plate and Dimpled.

#### \* STEP 7 - Locking and Polarizing Systems

- 0 - None.
- T - Fixed Female Jackscrews.
- T2 - Fixed Female Jackscrews.
- T6 - Fixed Male and Female Polarized Jackscrews.
- E - Rotating Male Jackscrews.
- E2 - Rotating Male Screw Locks.
- E6 - Rotating Male and Female Polarized Jackscrews.

#### \* STEP 6 - Hoods and Push-On Fasteners

- 0 - None.
- H - Hood, Top Opening, Brass.
- M - Hood, Top Opening, Aluminum, see page 52 for complete listing of options.
- N - Push-on Fastener for 90° Mounting Brackets.

#### \* NOTE:

For additional information on accessories listed in Steps 5, 6, and 7, see the Accessory Section, pages 48-54.

For SDD crimping tool information, see pages 13, 14, and 16.

**AUTOMATIC FEED,  
STRIP AND CRIMP TOOL,  
PNEUMATICALLY ACTUATED****Part No. 9550-1**

This fast-cycling automatic feed, strip and crimp tool produces an 8 indent crimp on wire sizes 22 AWG (0.3 mm<sup>2</sup>) through 30 AWG (0.05 mm<sup>2</sup>). SDD Series contacts must be ordered on reels.

To order, specify part number 9550-1. Foot control valve is supplied as a standard accessory.

**MINIATURE STEP ADJUSTABLE TOOL****(M22520/2-01)****Part No. 9507**

This miniature step adjustable hand crimping tool produces an 8 indent crimp configuration and will crimp wire sizes 22 AWG (0.3 mm<sup>2</sup>) through 30 AWG (0.05 mm<sup>2</sup>).

To crimp female contacts, order contact positioner 9502-3. To crimp male contacts, order contact positioner 9502-4. Each positioner is equipped with a data plate which gives the correct crimp-depth setting for each wire size, and must be used with 9507 tool frame for best results when crimping SDD Series contacts.

**INSERTION/REMOVAL TOOL****(M81969/1-04)**

One end of this tool is used to insert contacts into SDD Series connectors. The other end is used to extract contacts. This is accomplished by sliding the extraction tip down the wire into the connector until it bottoms against the contact. A slight rotation while pushing will release the contacts, which are then extracted by simultaneously pulling on the wire.

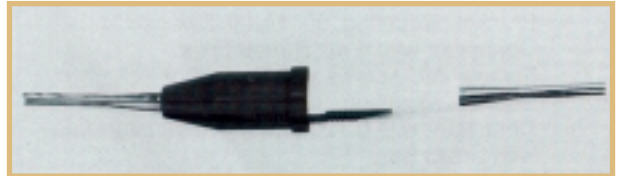

Size 20 Signal Contacts,  
Fixed Solder Cup and  
Printed Board Mountable

Size 8 Shielded and Power  
Removable, Printed Board  
Mountable

Space Application  
Quality Connectors

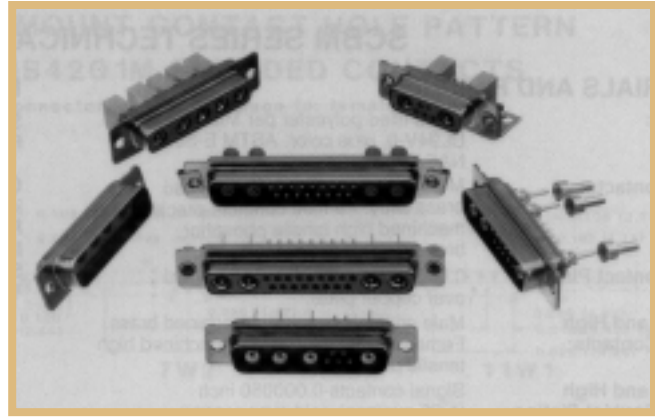

Space Combination Contact Subminiature-D connectors, Series SCBM, are space flight application quality rectangular connectors designed especially to withstand the rigors of launch and subsequent extended space flight. The SCBM Series features fixed contacts having solder cup terminations and printed board mount terminations for panel mounting and 90° and straight printed board applications.

The materials, dimensions, and performance of the SCBM Series conform to the requirements of DESC drawing 85039 and GSFC S-311-P-10 where applicable. The SCBM Series fully complies to the outgassing requirements

of ASTM E-595 and NASA-RP-1124.

The SCBM Series utilizes precision machined contacts with the female contact featuring a "Closed-Entry" design having a brass protective shroud.

Twenty standard combination contact variants are available, utilizing six shell sizes. Each connector variant is offered with contact terminations for solder cup and 90° terminations for printed board mounting.

Nonmagnetic cable supports and jackscrew systems are available.

Visual and mechanical inspection per MIL-DTL-24308 is performed, additional testing is available. Contact Technical Sales.

## SCBM SERIES CONTACT VARIANTS

FACE VIEW OF MALE OR REAR VIEW OF FEMALE

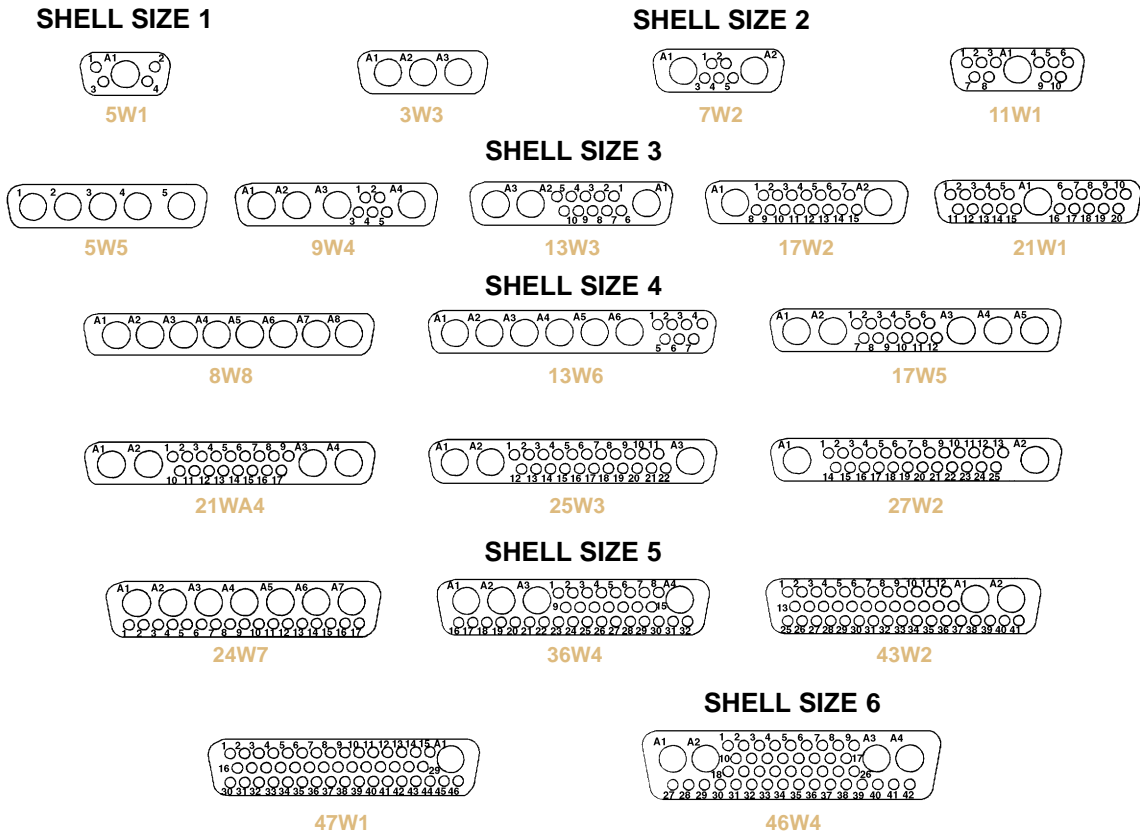

### SCBM SERIES TECHNICAL CHARACTERISTICS

#### MATERIALS AND FINISHES:

<b>Insulator:</b>	Glass-filled polyester per MIL-M-24519, UL 94V-0, ASTM E-595, NASA-RP-1124, blue color.
<b>Signal Contacts:</b>	<b>Male Contacts:</b> Precision machined brass alloy. <b>Female Contacts:</b> Precision machined high tensile phosphor bronze with brass shroud.
<b>Signal Contact Plating:</b>	0.000050 inch (1.25 microns) gold over copper plate.
<b>Power Contacts:</b>	Machined of high conductivity copper alloy for both male and female contacts.
<b>Power Contact Plating:</b>	0.000050 inch (1.25 microns) gold over copper plate.
<b>Shielded Contacts:</b>	<b>Male Contacts:</b> Precision machined brass. <b>Female Contacts:</b> Precision machined high tensile phosphor bronze.
<b>Shielded Contact Plating:</b>	<b>Signal Contacts:</b> 0.000050 inch (1.25 microns) gold over copper plate.
<b>Shells:</b>	Brass with 0.000050 inch (1.25 microns) gold over copper plate.
<b>Mounting Spacers and Brackets:</b>	Brass with 0.000050 inch (1.25 microns) gold over copper plate.
<b>Push-On Fasteners:</b>	Phosphor bronze or beryllium copper with 0.000050 inch (1.25 microns) gold over copper plate.
<b>Jackscrew Systems:</b>	Brass with 0.000050 inch (1.25 microns) gold over copper plate.
<b>Hoods:</b>	Brass with 0.000050 inch (1.25 microns) gold over copper plate or aluminum yellow chromate conversion or black anodize.

#### ELECTRICAL CHARACTERISTICS:

<b>SIGNAL CONTACTS:</b>	
<b>Contact Current Rating:</b>	7.5 amps, nominal.
<b>Initial Contact Resistance:</b>	0.008 ohms, maximum.
<b>Proof Voltage:</b>	1,000 V r.m.s.
<b>POWER CONTACTS:</b>	
<b>Contact Current Rating:</b>	10, 15, 20, 30, and 40 amperes, nominal.
<b>Initial Contact Resistance:</b>	0.005 ohms, maximum.
<b>Proof Voltage:</b>	1,000 V r.m.s.
<b>SHIELDED CONTACTS:</b>	
<b>Initial Contact Resistance:</b>	0.008 ohms, maximum.
<b>Nominal Impedance:</b>	50 ohms.
<b>Insertion Loss:</b>	-0.46 dB at 1 GHz -1.5 dB at 2 GHz
<b>VSWR:</b>	1.15 average at 1 GHz 1.56 average at 2 GHz
Above values measured using frequency domain techniques.	
<b>Proof Voltage:</b>	1,000 V r.m.s.
<b>CONNECTOR:</b>	
<b>Insulator Resistance:</b>	5 G ohms.
<b>Creepage and Clearance Distance:</b>	0.039 inch (1.0 mm), minimum.
<b>Working Voltage:</b>	300 V r.m.s.
<b>Residual Magnetism:</b>	20 Gamma, maximum.

#### CLIMATIC CHARACTERISTICS:

<b>Temperature Range:</b>	-55°C to +125°C.
<b>Damp Heat, Steady State:</b>	21 days.

#### MECHANICAL CHARACTERISTICS:

<b>Signal Contacts, Fixed:</b>	Size 20 contacts. <b>Male Contact:</b> 0.040 inch (1.02 mm) diameter. <b>Female Contact:</b> Closed entry design with brass shroud.
<b>Contact Retention in Insulator:</b>	<b>Signal Contacts:</b> 9 lbs. (40N). <b>Power, and Shielded Contacts:</b> 22 lbs. (98N).
<b>Resistance to Solder Iron Heat:</b>	500°F (260°C) for 10 seconds duration per IEC 512-6.
<b>Signal Contact Terminations:</b>	
<b>Solder Contacts:</b>	0.042 inch (1.06 mm) minimum hole diameter for 20 AWG (0.5 mm <sup>2</sup> ) wire, maximum.
<b>Straight Printed Board Mount:</b>	0.028 inch (0.71 mm) diameter.
<b>90° Printed Board Mount:</b>	0.028 inch (0.71 mm) diameter.
<b>Power Contacts, Removable, Crimp or Solder Terminations:</b>	Size 8 contacts. <b>Male Contact:</b> 0.142 inch (3.61 mm) diameter. <b>Female Contact:</b> Features Large Surface Area (L.S.A.) Closed entry design utilizing BeCu mechanical retention member. Male and female contacts have terminations for wire sizes 8, 12, and 16 AWG.
<b>Power Contacts, Printed Board Mount:</b>	Size 8 contact. <b>Male Contact:</b> 0.142 inch (3.61 mm) diameter. Printed board terminations with 0.078 inch (1.98 mm) and 0.125 inch (3.18 mm) diameters.
<b>Shielded Contacts, Removable:</b>	See table of maximum cable sizes for contact termination dimensions, pages 34 and 35.
<b>Shells:</b>	Male shells may be dimpled for EM/ESD ground paths.
<b>Polarization:</b>	Trapezoidally shaped shells and polarized jackscrews.
<b>Mounting to Angle Brackets:</b>	Jackscrews and riveted fasteners with 0.120 inch (3.05 mm) diameter hole, and threaded riveted fasteners with 4-40 threads and polyester inserts.
<b>Mounting to Printed Board:</b>	Rapid installation push-on fasteners and threaded posts.
<b>Locking Systems:</b>	Jackscrews.
<b>Mechanical Operations:</b>	1,000 operations per IEC 512-5.

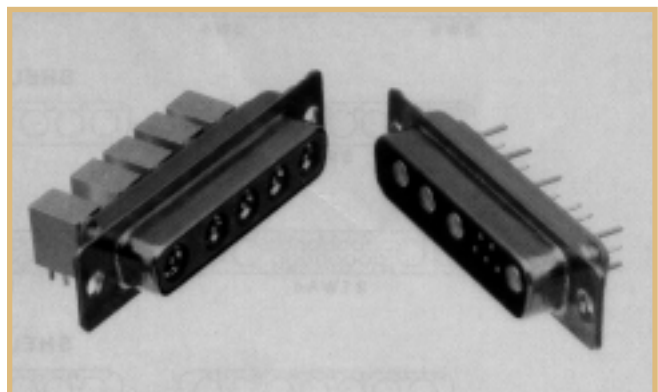

SCBM5W5F85000G

SCBM9W4M65000G



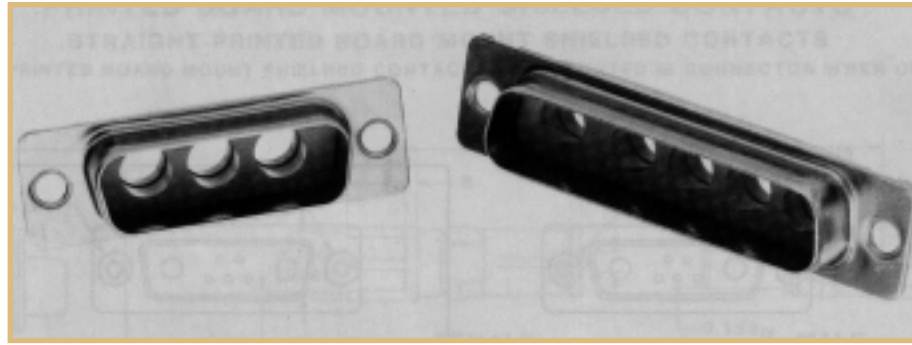

SCBM3W3M0000G

SCBM5W5M0000G

### STANDARD SHELL ASSEMBLY

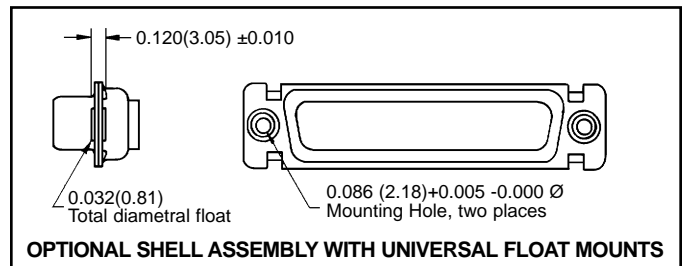
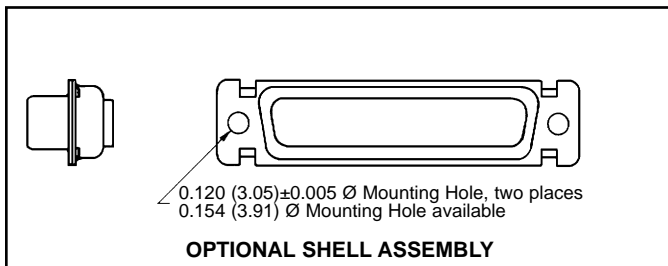
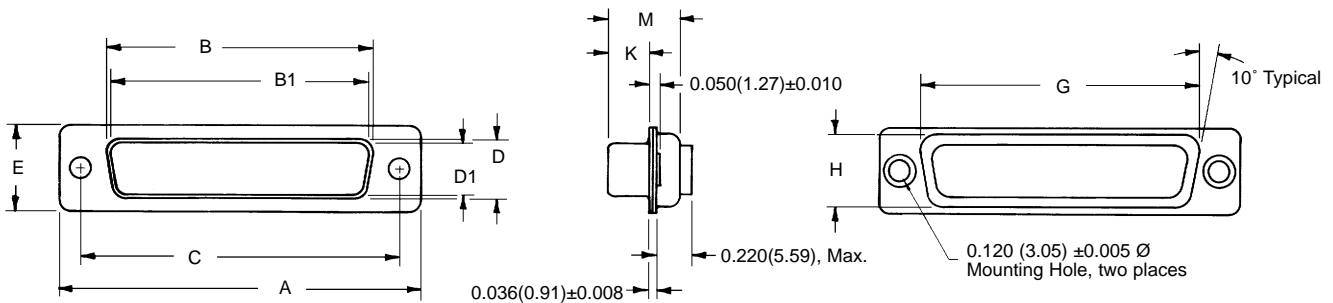

SHELL SIZE	A ±0.015	B ±0.005	B1 ±0.005	C ±0.005	D ±0.005	D1 ±0.005	E ±0.015	G ±0.010	H ±0.010	K ±0.005	M ±0.010
SHELL SIZE 1 MALE	1.213 (30.81)		0.666 (16.92)	0.984 (24.99)		0.329 (8.36)	0.494 (12.55)	0.759 (19.28)	0.422 (10.72)	0.233 (5.92)	0.422 (10.72)
SHELL SIZE 1 FEMALE	1.213 (30.81)	0.643 (16.33)		0.984 (24.99)	0.311 (7.90)		0.494 (12.55)	0.759 (19.28)	0.422 (10.72)	0.243 (6.17)	0.429 (10.90)
SHELL SIZE 2 MALE	1.541 (39.14)		0.994 (25.25)	1.312 (33.32)		0.329 (8.36)	0.494 (12.55)	1.083 (27.51)	0.422 (10.72)	0.233 (5.92)	0.422 (10.72)
SHELL SIZE 2 FEMALE	1.541 (39.14)	0.971 (24.66)		1.312 (33.32)	0.311 (7.90)		0.494 (12.55)	1.083 (27.51)	0.422 (10.72)	0.243 (6.17)	0.429 (10.90)
SHELL SIZE 3 MALE	2.088 (53.04)		1.534 (38.96)	1.852 (47.04)		0.329 (8.36)	0.494 (12.55)	1.625 (41.28)	0.422 (10.72)	0.230 (5.84)	0.426 (10.82)
SHELL SIZE 3 FEMALE	2.088 (53.04)	1.511 (38.38)		1.852 (47.04)	0.311 (7.90)		0.494 (12.55)	1.625 (41.28)	0.422 (10.72)	0.243 (6.17)	0.429 (10.90)
SHELL SIZE 4 MALE	2.729 (69.32)		2.182 (55.42)	2.500 (63.50)		0.329 (8.36)	0.494 (12.55)	2.272 (57.71)	0.422 (10.72)	0.230 (5.84)	0.426 (10.82)
SHELL SIZE 4 FEMALE	2.729 (69.32)	2.159 (54.84)		2.500 (63.50)	0.311 (7.90)		0.494 (12.55)	2.272 (57.71)	0.422 (10.72)	0.243 (6.17)	0.429 (10.90)
SHELL SIZE 5 MALE	2.635 (66.93)		2.079 (52.81)	2.406 (61.11)		0.441 (11.20)	0.605 (15.37)	2.178 (55.32)	0.534 (13.56)	0.230 (5.84)	0.426 (10.82)
SHELL SIZE 5 FEMALE	2.635 (66.93)	2.064 (52.43)		2.406 (61.11)	0.423 (10.74)		0.605 (15.37)	2.178 (55.32)	0.534 (13.56)	0.243 (6.17)	0.429 (10.90)
SHELL SIZE 6 MALE	2.729 (69.32)		2.212 (56.18)	2.500 (63.50)		0.503 (12.78)	0.668 (16.97)	2.302 (58.47)	0.596 (15.14)	0.230 (5.84)	0.426 (10.82)
SHELL SIZE 6 FEMALE	2.729 (69.32)	2.189 (55.60)		2.500 (63.50)	0.485 (12.32)		0.668 (16.97)	2.302 (58.47)	0.596 (15.14)	0.243 (6.17)	0.429 (10.90)

DIMENSIONS ARE IN INCHES (MILLIMETERS). ALL DIMENSIONS ARE SUBJECT TO CHANGE.

### SOLDER CONNECTOR

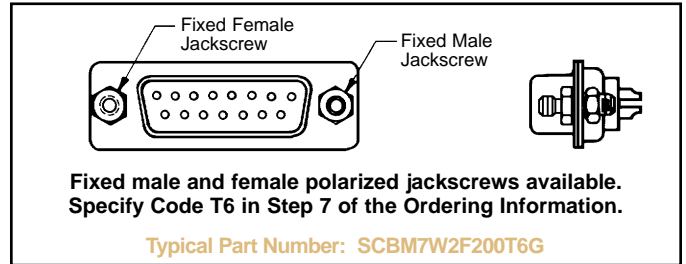
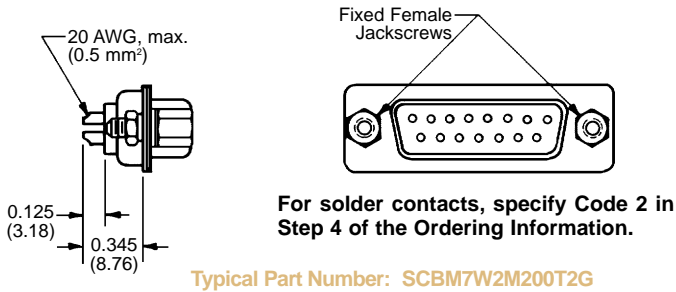

### STRAIGHT PRINTED BOARD MOUNT CONNECTOR WITH SIZE 8 CONTACTS

CODE NUMBER	D Ø
3	-----
35	0.078 (1.98)
37	0.125 (3.18)

For straight printed board mount contacts, specify Code Number in Step 4 of the Ordering Information.

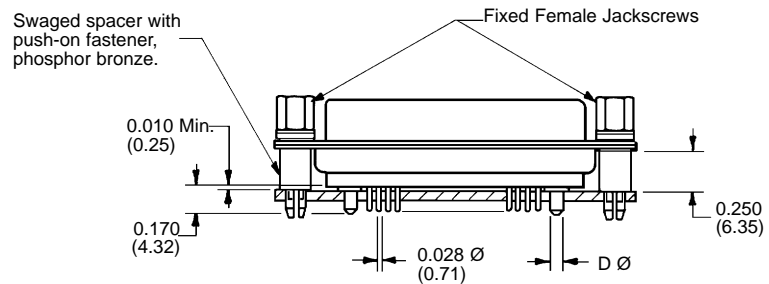

SCBM21WA4M2000G WITH MS4820M

SCBM21WA4F65S00G

### PRINTED BOARD MOUNTED POWER CONTACTS

#### STRAIGHT PRINTED BOARD MOUNT POWER CONTACTS

Straight printed board mount power contacts are mounted in connector when ordered.

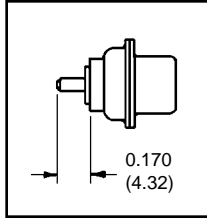

\*FEMALE CLOSED ENTRY, L.S.A.

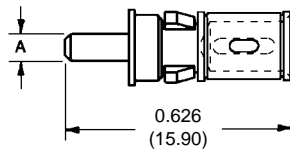

MALE

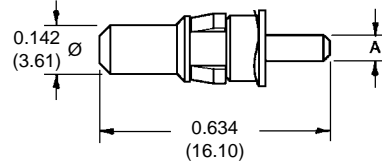

PART NUMBER	A Ø	CURRENT RATING
FDS4314M	0.078 (1.98)	15 Amps.
FDS4310M	0.125 (3.18)	30 Amps.

PART NUMBER	A Ø	CURRENT RATING
MDS4314M	0.078 (1.98)	15 Amps.
MDS4310M	0.125 (3.18)	30 Amps.

**Material** - High conductivity copper alloy.  
**Plating** - 0.000050 inch (1.25µ) gold over copper.

### RIGHT ANGLE PRINTED BOARD MOUNT POWER CONTACTS

Right angle printed board mount power contacts are mounted in connector when ordered.

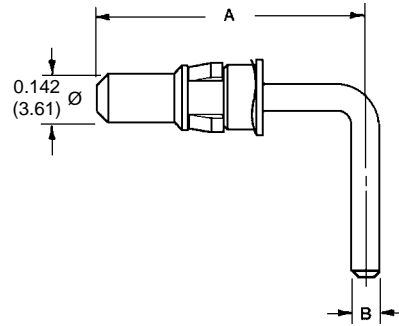
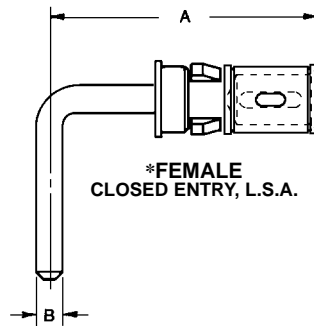
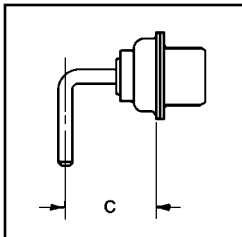

PART NUMBER	CURRENT	A REF.	B Ø	C	SHELL SIZE	BEND CODE
FRT4314M	15 Amps	0.580 (14.73)	0.078 (1.98)	0.339 (8.61)	1, 2, 3 & 4	55
FRT4414M	15 Amps	0.692 (17.58)	0.078 (1.98)	0.451 (11.46)	5	55
FRT4714M	15 Amps	0.661 (16.79)	0.078 (1.98)	0.420 (10.67)	1, 2, 3 & 4	75
FRT4814M	15 Amps	0.773 (19.63)	0.078 (1.98)	0.520 (13.21)	5	75
FRT4310M	30 Amps	1.036 (26.31)	0.125 (3.18)	0.810 (20.57)	1, 2, 3 & 4	*
FRT4410M	30 Amps	1.036 (26.31)	0.125 (3.18)	0.810 (20.57)	5	*

PART NUMBER	CURRENT	A REF.	B Ø	C	SHELL SIZE	BEND CODE
MRT4314M	15 Amps	0.580 (14.73)	0.078 (1.98)	0.339 (8.61)	1, 2, 3 & 4	55
MRT4414M	15 Amps	0.692 (17.58)	0.078 (1.98)	0.451 (11.46)	5	55
MRT4714M	15 Amps	0.661 (16.79)	0.078 (1.98)	0.420 (10.67)	1, 2, 3 & 4	75
MRT4814M	15 Amps	0.773 (19.63)	0.078 (1.98)	0.520 (13.21)	5	75
MRT4310M	30 Amps	1.036 (26.31)	0.125 (3.18)	0.810 (20.57)	1, 2, 3 & 4	*
MRT4410M	30 Amps	1.036 (26.31)	0.125 (3.18)	0.810 (20.57)	5	*

**Material** - High conductivity copper alloy.  
**Plating** - 0.000050 inch (1.25µ) gold over copper.

\*Note: Female power contacts feature Large Surface Area (L.S.A.) closed entry contact design which provides maximum mating surfaces between male and female contacts and reduced contact resistance during operation.

DIMENSIONS ARE IN INCHES (MILLIMETERS)  
ALL DIMENSIONS SUBJECT TO CHANGE

### RIGHT ANGLE PRINTED BOARD MOUNT CONNECTOR WITH 0.125(3.18) Ø POWER CONTACTS

CODE 5 AND 57, 0.283(7.19) CONTACT EXTENSION  
(30 AMPS NOMINAL)

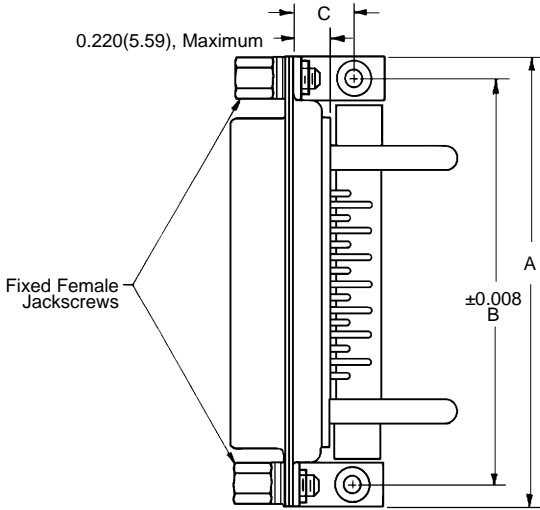

SCBM00*R7000 0.283(7.19) CONTACT EXTENSION				
SHELL SIZE	A	B	C	D
SHELL SIZE 1	1.204 (30.58)	0.984 (24.99)	0.339 (8.61)	0.283 (7.19)
SHELL SIZE 2	1.532 (38.91)	1.312 (33.32)	0.339 (8.61)	0.283 (7.19)
SHELL SIZE 3	2.072 (52.63)	1.852 (47.04)	0.339 (8.61)	0.283 (7.19)
SHELL SIZE 4	2.720 (69.09)	2.500 (63.50)	0.339 (8.61)	0.283 (7.19)
SHELL SIZE 5	2.626 (66.70)	2.406 (61.11)	0.395 (10.03)	0.283 (7.19)

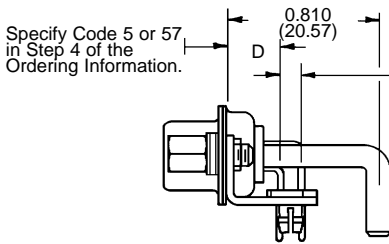

Typical Part Number:  
SCBM17W2M57R7NT2G

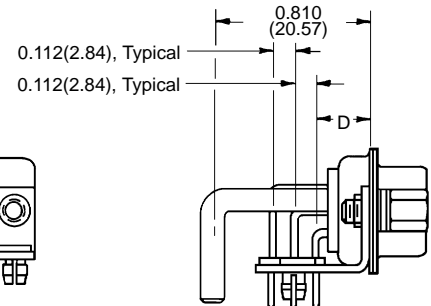
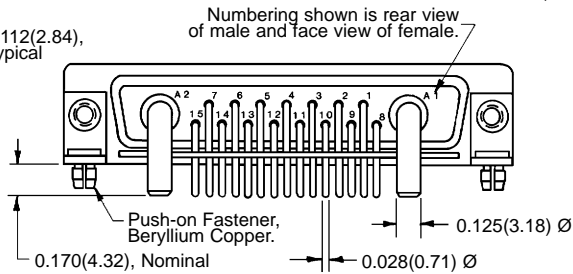

Typical Part Number:  
SCBM36W4F57R7NT2G

### RIGHT ANGLE PRINTED BOARD MOUNT CONNECTOR WITH 0.078(1.98) Ø POWER CONTACTS

CODE 5 AND 55, 0.283(7.19) CONTACT EXTENSION  
(15 AMPS NOMINAL)

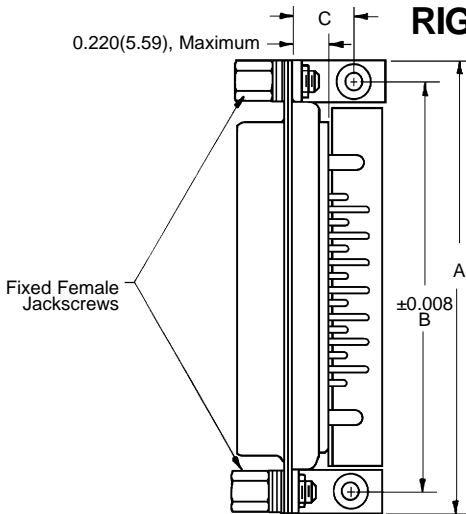

SCBM00*R7000 0.283(7.19) CONTACT EXTENSION				
SHELL SIZE	A	B	C	D
SHELL SIZE 1	1.204 (30.58)	0.984 (24.99)	0.339 (8.61)	0.283 (7.19)
SHELL SIZE 2	1.532 (38.91)	1.312 (33.32)	0.339 (8.61)	0.283 (7.19)
SHELL SIZE 3	2.072 (52.63)	1.852 (47.04)	0.339 (8.61)	0.283 (7.19)
SHELL SIZE 4	2.720 (69.09)	2.500 (63.50)	0.339 (8.61)	0.283 (7.19)
SHELL SIZE 5	2.626 (66.70)	2.406 (61.11)	0.395 (10.03)	0.283 (7.19)

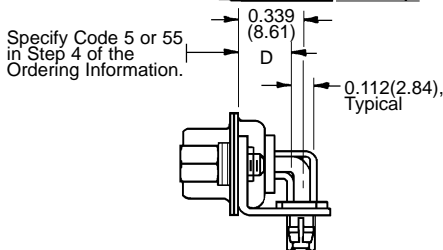

Typical Part Number:  
SCBM17W2M55R7NT2G

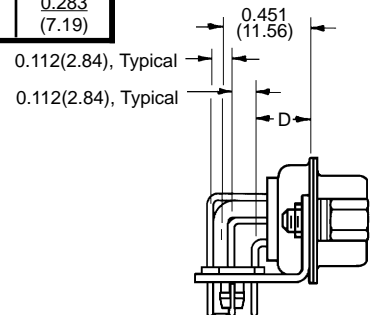
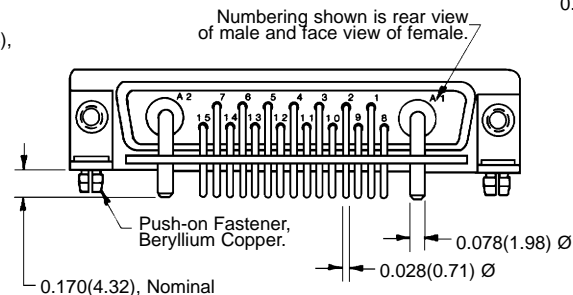

Typical Part Number:  
SCBM36W4F55R7NT2G

DIMENSIONS ARE IN INCHES (MILLIMETERS). ALL DIMENSIONS ARE SUBJECT TO CHANGE.

### METRIC SYSTEM 90° PRINTED BOARD MOUNT CONNECTOR WITH 0.078(1.98) Ø POWER CONTACTS CODE 7 AND 75, 0.370(9.40) CONTACT EXTENSION (15 AMPS NOMINAL)

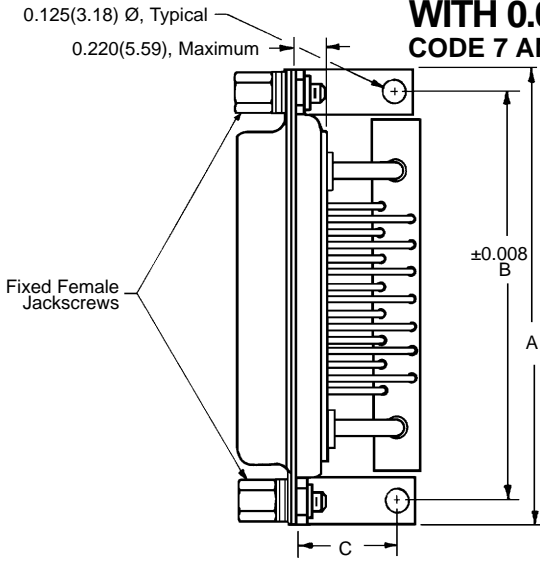

SCBM00*R7000 0.370(9.40) CONTACT EXTENSION				
SHELL SIZE	A	B	C	D
SHELL SIZE 1	1.204 (30.58)	0.984 (24.99)	0.420 (10.67)	0.370 (9.40)
SHELL SIZE 2	1.532 (38.91)	1.312 (33.32)	0.420 (10.67)	0.370 (9.40)
SHELL SIZE 3	2.072 (52.63)	1.852 (47.04)	0.420 (10.67)	0.370 (9.40)
SHELL SIZE 4	2.720 (69.09)	2.500 (63.50)	0.420 (10.67)	0.370 (9.40)
SHELL SIZE 5	2.626 (66.70)	2.406 (61.11)	0.470 (11.94)	0.370 (9.40)

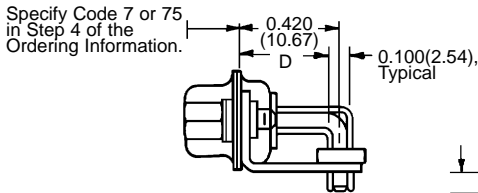

Typical Part Number:  
SCBM17W2M75R70T2G

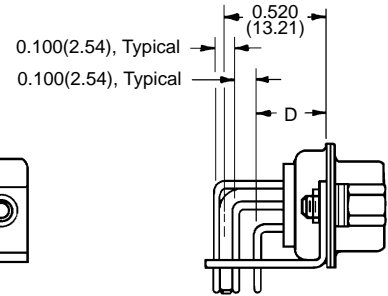
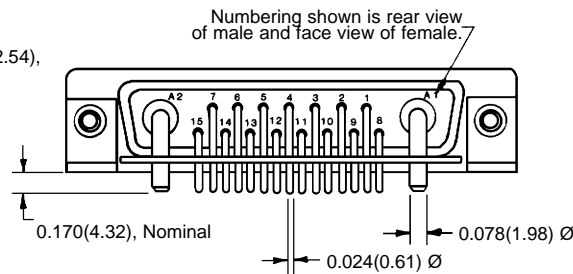

Typical Part Number:  
SCBM36W4M75R70T2G

### METRIC SYSTEM 90° PRINTED BOARD MOUNT CONNECTOR WITH 0.125(3.18) Ø POWER CONTACTS CODE 7 AND 77, 0.370(9.40) CONTACT EXTENSION (30 AMPS NOMINAL)

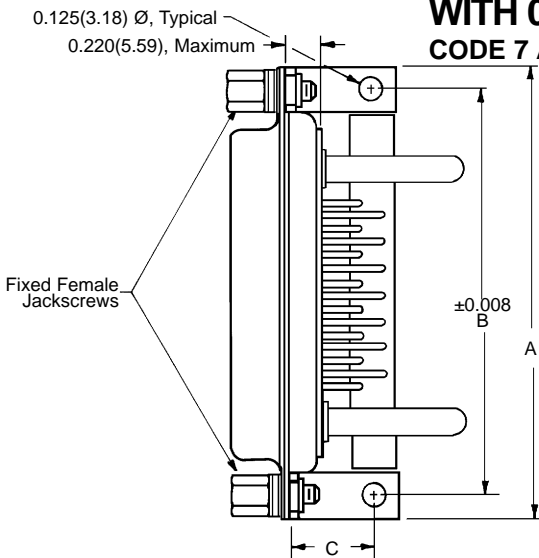

SCBM00*R7000 0.370(9.40) CONTACT EXTENSION				
SHELL SIZE	A	B	C	D
SHELL SIZE 1	1.204 (30.58)	0.984 (24.99)	0.420 (10.67)	0.370 (9.40)
SHELL SIZE 2	1.532 (38.91)	1.312 (33.32)	0.420 (10.67)	0.370 (9.40)
SHELL SIZE 3	2.072 (52.63)	1.852 (47.04)	0.420 (10.67)	0.370 (9.40)
SHELL SIZE 4	2.720 (69.09)	2.500 (63.50)	0.420 (10.67)	0.370 (9.40)
SHELL SIZE 5	2.626 (66.70)	2.406 (61.11)	0.470 (11.94)	0.370 (9.40)

DIMENSIONS ARE IN INCHES (MILLIMETERS). ALL DIMENSIONS ARE SUBJECT TO CHANGE.

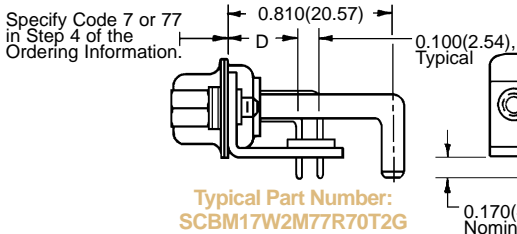

Typical Part Number:  
SCBM17W2M77R70T2G

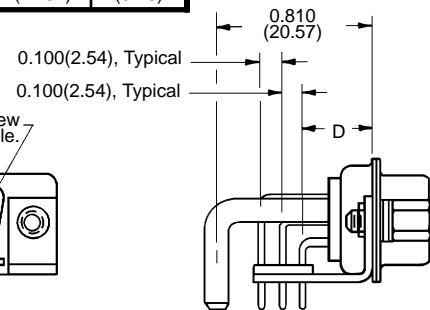
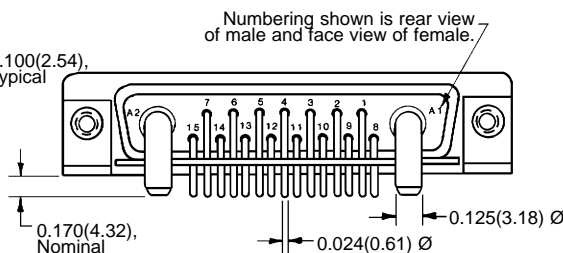

Typical Part Number:  
SCBM36W4M77R70T2G



**SHELL SIZE 6  
90° PRINTED BOARD MOUNT CONNECTOR  
WITH 0.078(1.98) Ø POWER CONTACTS  
CODE 5 AND 55, 0.283(7.19) CONTACT EXTENSION  
CONNECTOR VARIANT 46W4  
(15 AMPS NOMINAL)**

**SHELL SIZE 6 CONNECTOR**

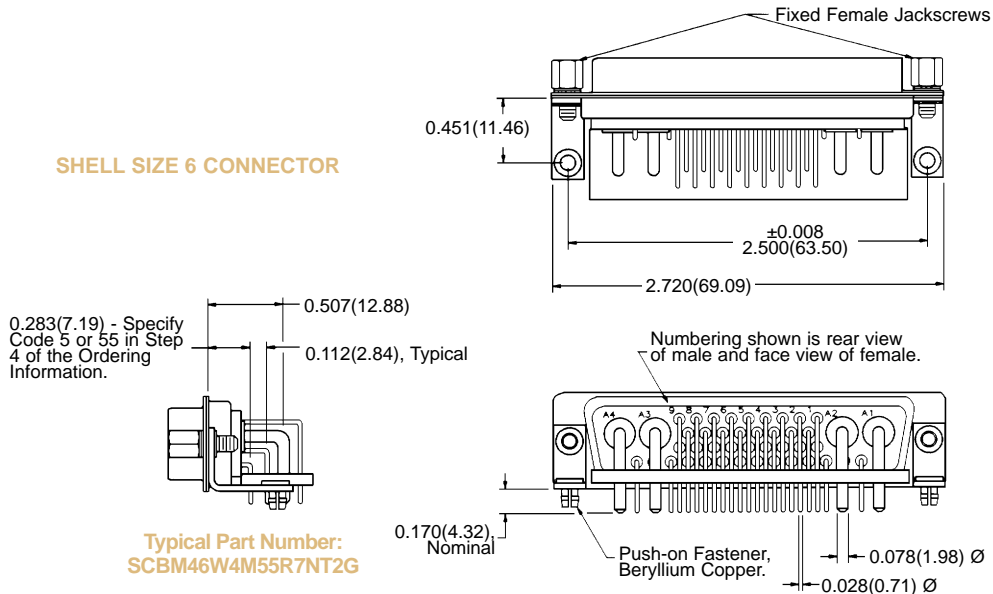

**SHELL SIZE 6  
90° PRINTED BOARD MOUNT CONNECTOR  
WITH 0.125(3.18) Ø POWER CONTACTS  
CODE 5 AND 57, 0.283(7.19) CONTACT EXTENSION  
CONNECTOR VARIANT 46W4  
(30 AMPS NOMINAL)**

**SHELL SIZE 6 CONNECTOR**

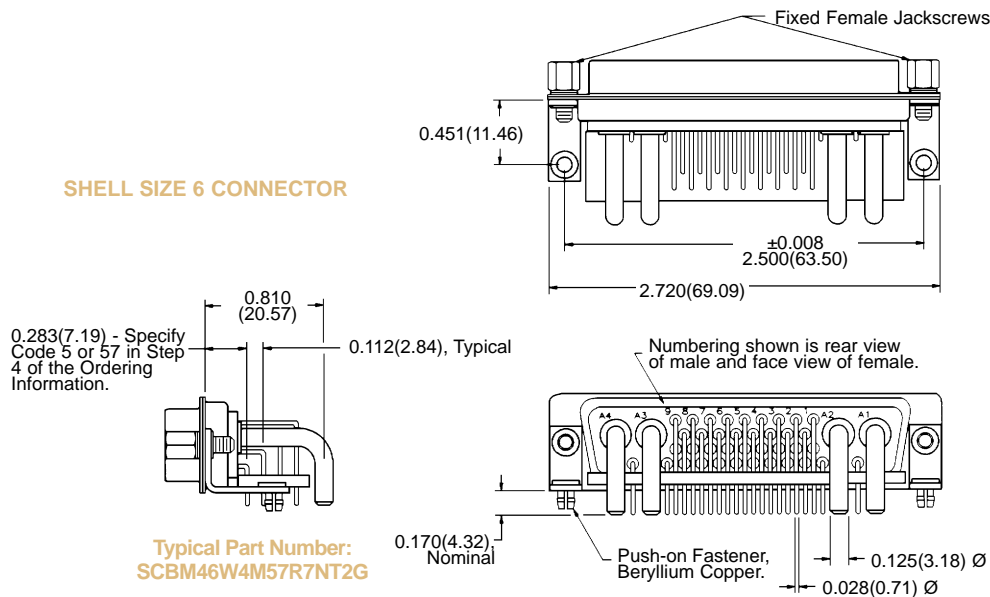

DIMENSIONS ARE IN INCHES (MILLIMETERS).  
ALL DIMENSIONS ARE SUBJECT TO CHANGE.

### RIGHT ANGLE AND STRAIGHT PRINTED BOARD CONTACT HOLE PATTERN WITH 0.078(1.98) Ø AND STRAIGHT PRINTED BOARD MOUNT 0.125(3.18) Ø POWER CONTACTS

Hole identification shown for male connector; use mirror image for female connector.  
Mount connector with mating face positioned to follow direction of arrows.

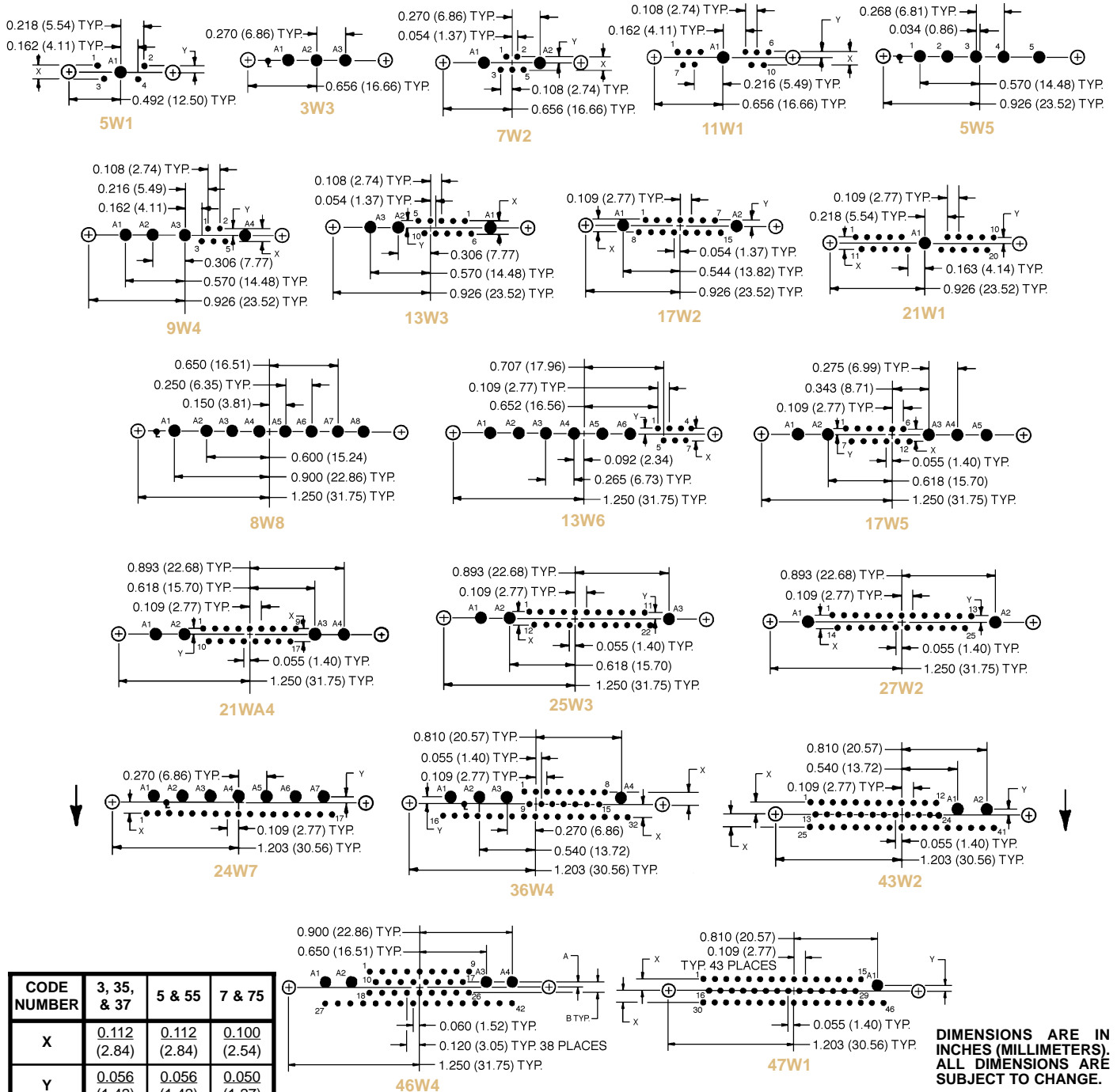

CODE NUMBER	3, 35, & 37	5 & 55	7 & 75
X	0.112 (2.84)	0.112 (2.84)	0.100 (2.54)
Y	0.056 (1.42)	0.056 (1.42)	0.050 (1.27)
A	0.100 (2.54)	0.112 (2.84)	0.100 (2.54)
B	0.050 (1.27)	0.056 (1.42)	0.050 (1.27)

DIMENSIONS ARE IN INCHES (MILLIMETERS). ALL DIMENSIONS ARE SUBJECT TO CHANGE.

- Suggest 0.045(1.14) Ø hole for signal contact termination positions.
- Suggest 0.098(2.49) Ø hole for 0.078(1.98) Ø power contact terminations.
- Suggest 0.145(3.68) Ø hole for 0.125(3.18) Ø power contact termination positions.
- Suggest 0.123 ±0.003 (3.12) Ø hole for mounting connector with push-on fasteners.

### RIGHT ANGLE PRINTED BOARD CONTACT HOLE PATTERN WITH 0.125(3.18) Ø POWER CONTACTS

Hole identification shown for male connector; use mirror image for female connector.  
Mount connector with mating face positioned to follow direction of arrows.

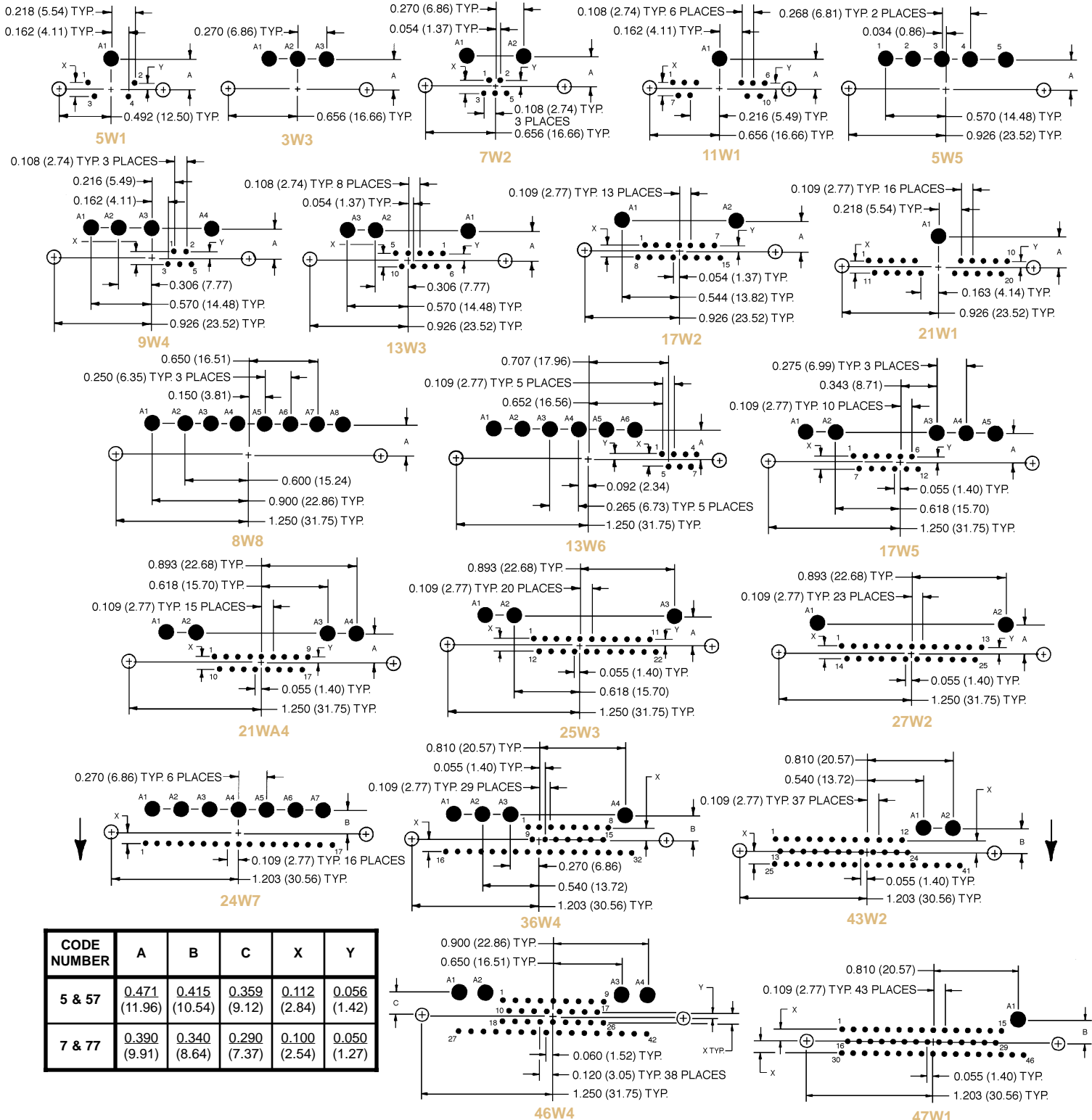

CODE NUMBER	A	B	C	X	Y
5 & 57	0.471 (11.96)	0.415 (10.54)	0.359 (9.12)	0.112 (2.84)	0.056 (1.42)
7 & 77	0.390 (9.91)	0.340 (8.64)	0.290 (7.37)	0.100 (2.54)	0.050 (1.27)

Suggest 0.045(1.14) Ø hole for signal contact termination positions.  
Suggest 0.145(3.68) Ø hole for 0.125(3.18) Ø power contact termination positions.  
Suggest 0.123 ±0.003 (3.12) Ø hole for mounting connector with push-on fasteners.

DIMENSIONS ARE IN INCHES (MILLIMETERS).  
ALL DIMENSIONS ARE SUBJECT TO CHANGE.

### PRINTED BOARD MOUNT SHIELDED CONTACTS

#### STRAIGHT PRINTED BOARD MOUNT SHIELDED CONTACTS

STRAIGHT PRINTED BOARD MOUNT SHIELDED CONTACTS ARE MOUNTED IN CONNECTOR WHEN ORDERED.

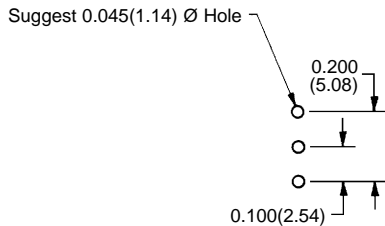
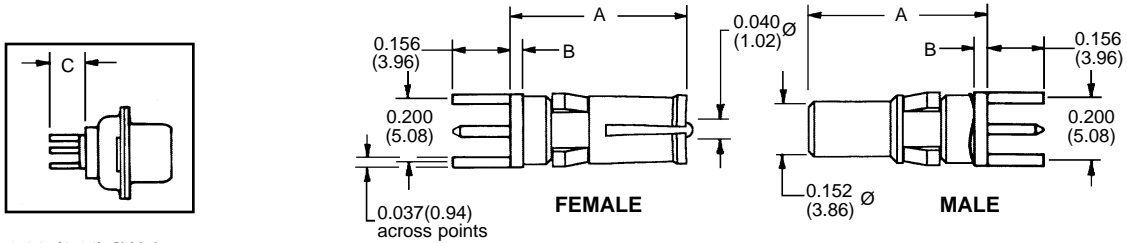

**FDS4201M and MDS4201M**  
Contact Hole Pattern

PART NUMBER	A	B	C
<b>FDS4201M</b>	0.481 (12.22)	0.025 (0.64)	0.181 (4.60)

PART NUMBER	A	B	C
<b>MDS4201M</b>	0.489 (12.42)	0.025 (0.64)	0.181 (4.60)

**Material:** Copper alloy with PTFE teflon insulator.  
**Signal Contact Plating:** 0.000050 inch (1.25 μ) gold over copper.  
**Contact Body Plating:** 0.000050 inch (1.25 μ) gold over copper.

\* Technical characteristics are listed on page 33.

### RIGHT ANGLE PRINTED BOARD MOUNT SHIELDED CONTACTS

90° PRINTED BOARD MOUNT SHIELDED CONTACTS ARE MOUNTED IN CONNECTOR WHEN ORDERED.

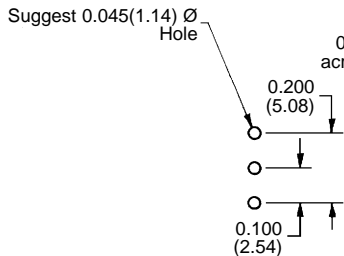
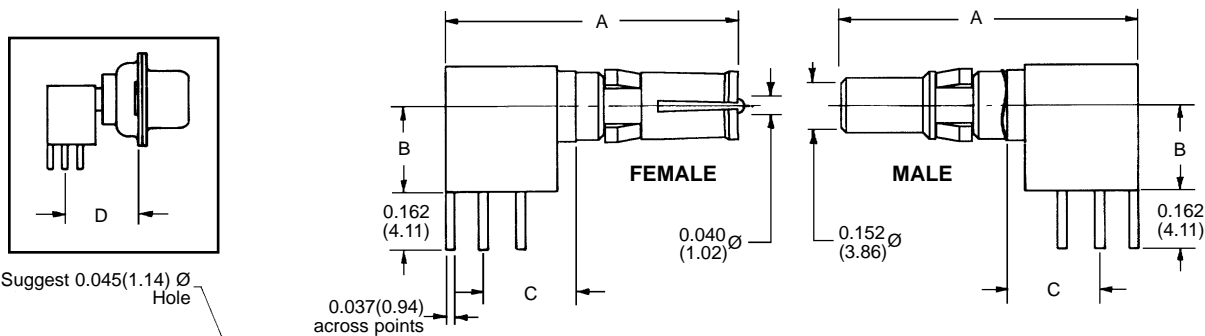

**FRT4201M and MRT4201M**  
Contact Hole Pattern

PART NUMBER	A	B	C	D
<b>FRT4201M</b>	0.827 (21.01)	0.240 (6.10)	0.259 (6.58)	0.470 (11.94)

PART NUMBER	A	B	C	D
<b>MRT4201M</b>	0.829 (21.06)	0.240 (6.10)	0.253 (6.43)	0.470 (11.94)

**Material:** Copper alloy with PTFE teflon insulator.  
**Signal Contact Plating:** 0.000050 inch (1.25 μ) gold over copper.  
**Contact Body Plating:** 0.000050 inch (1.25 μ) gold over copper.

\* Technical characteristics are listed on page 33.

DIMENSIONS ARE IN INCHES (MILLIMETERS).  
ALL DIMENSIONS ARE SUBJECT TO CHANGE.

### STRAIGHT PRINTED BOARD MOUNT CONNECTOR WITH SHIELDED CONTACTS

CODE 65, CONNECTOR WITH FDS4201M OR MDS4201M CONTACTS

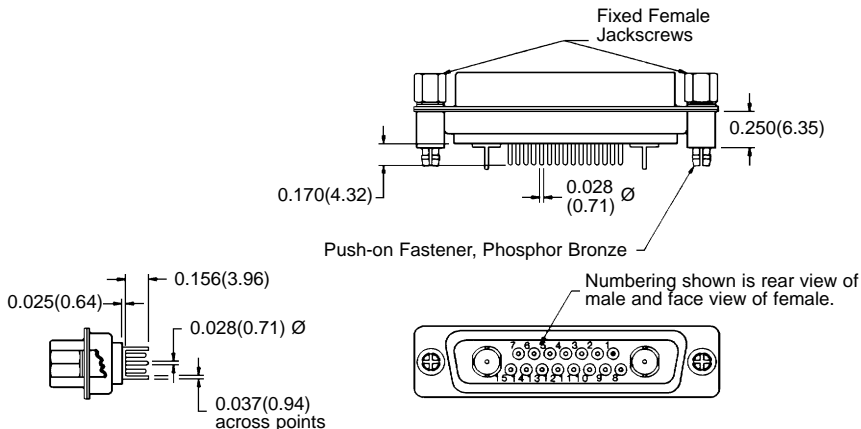

Typical Part Number:  
SCBM17W2M65S60T2G

### RIGHT ANGLE PRINTED BOARD MOUNT CONNECTOR WITH SHIELDED CONTACTS

CODE 85, CONNECTOR WITH FRT4201M OR MRT4201M CONTACTS

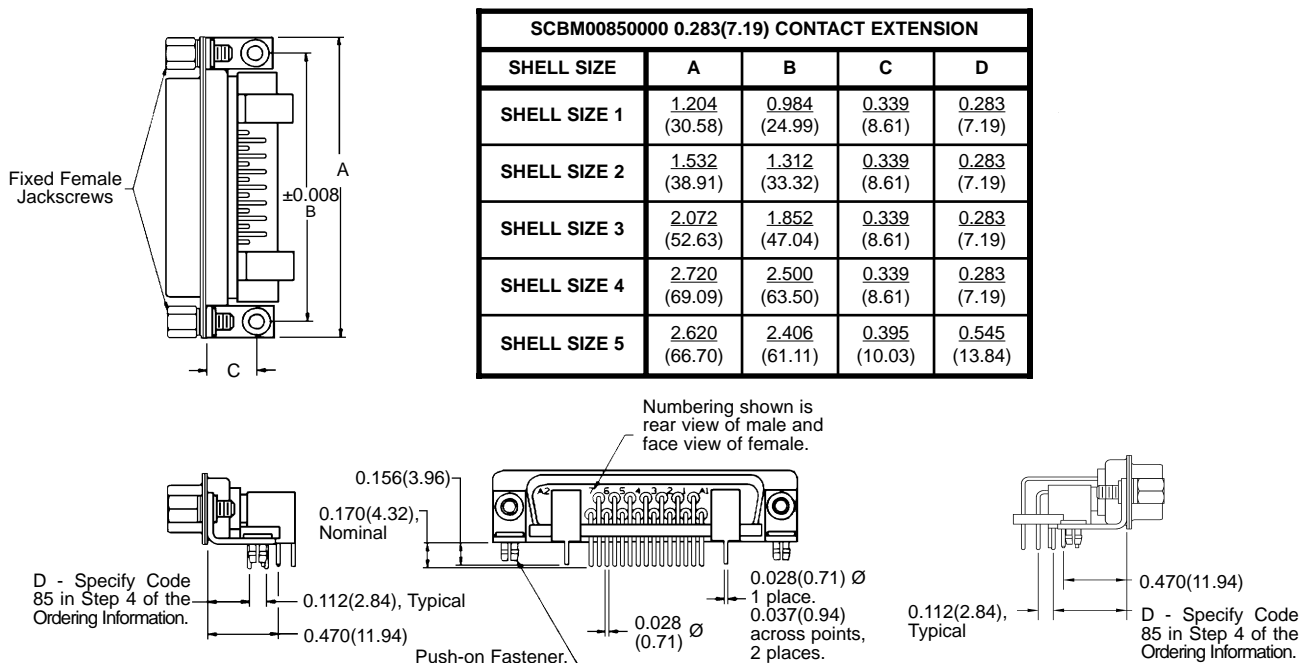

Typical Part Number:  
SCBM17W2M85R7NT2G

Typical Part Number:  
SCBM36W4M85R7NT2G

**NOTE:** Shell size 5 connectors are supplied inverted when ordered with 90° printed board mount shielded contact.

DIMENSIONS ARE IN INCHES (MILLIMETERS).  
ALL DIMENSIONS ARE SUBJECT TO CHANGE.



### STRAIGHT PRINTED BOARD MOUNT CONTACT HOLE PATTERN WITH FDS4201M AND MDS4201M SHIELDED CONTACTS

Hole identification shown is for male connector; use mirror image for female connector.

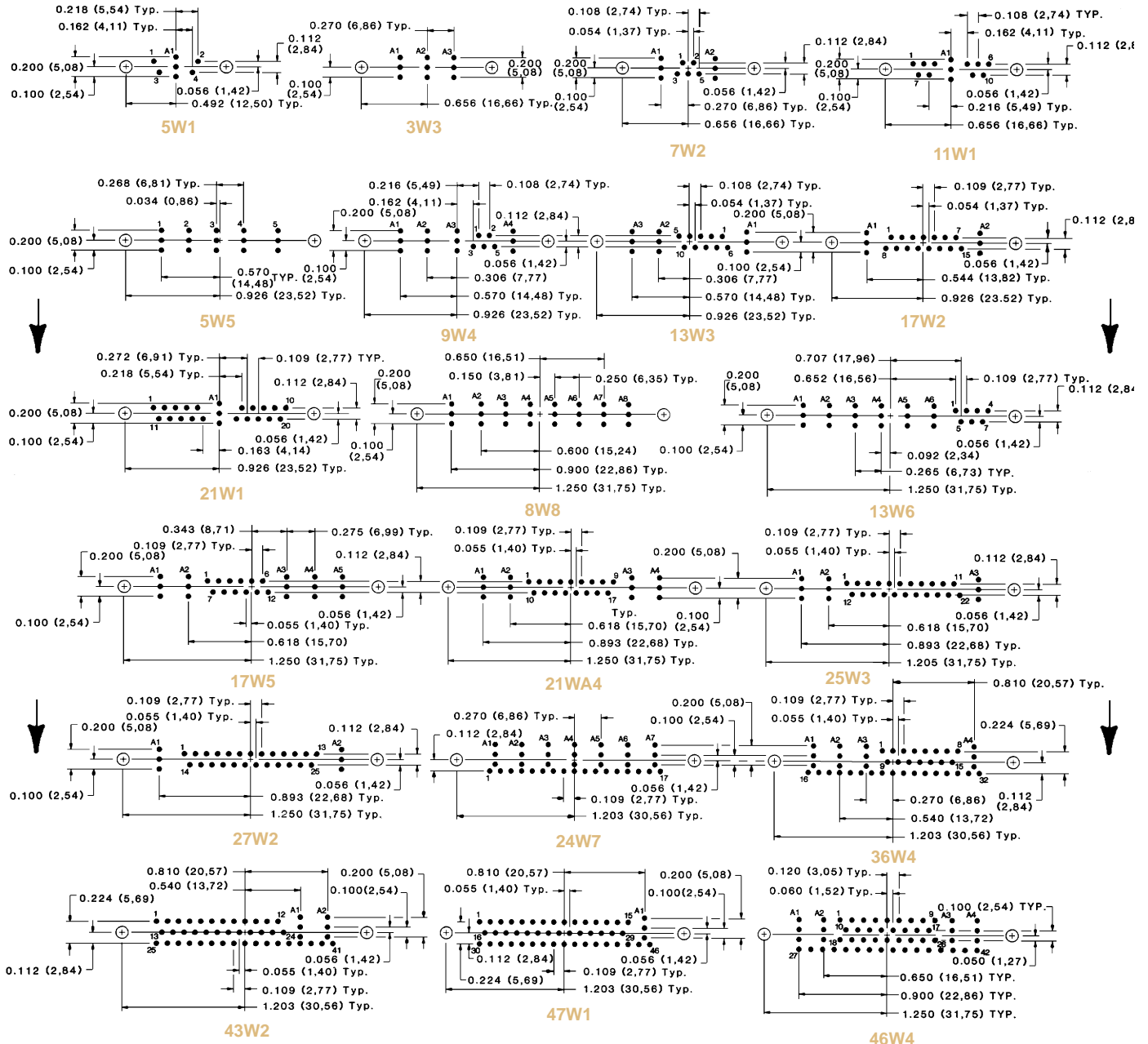

Suggest 0.045(1.14) Ø hole for signal contact termination position.  
Suggest 0.123 ±0.003 (3.12) Ø hole for mounting connector with push-on fastener.

DIMENSIONS ARE IN INCHES (MILLIMETERS).  
ALL DIMENSIONS ARE SUBJECT TO CHANGE.

### 90° PRINTED BOARD MOUNT CONTACT HOLE PATTERN WITH FRT4201M AND MRT4201M SHIELDED CONTACTS

Hole identification shown is for male connector; use mirror image for female connector.  
Mount connector with mating face positioned to follow direction of arrow.

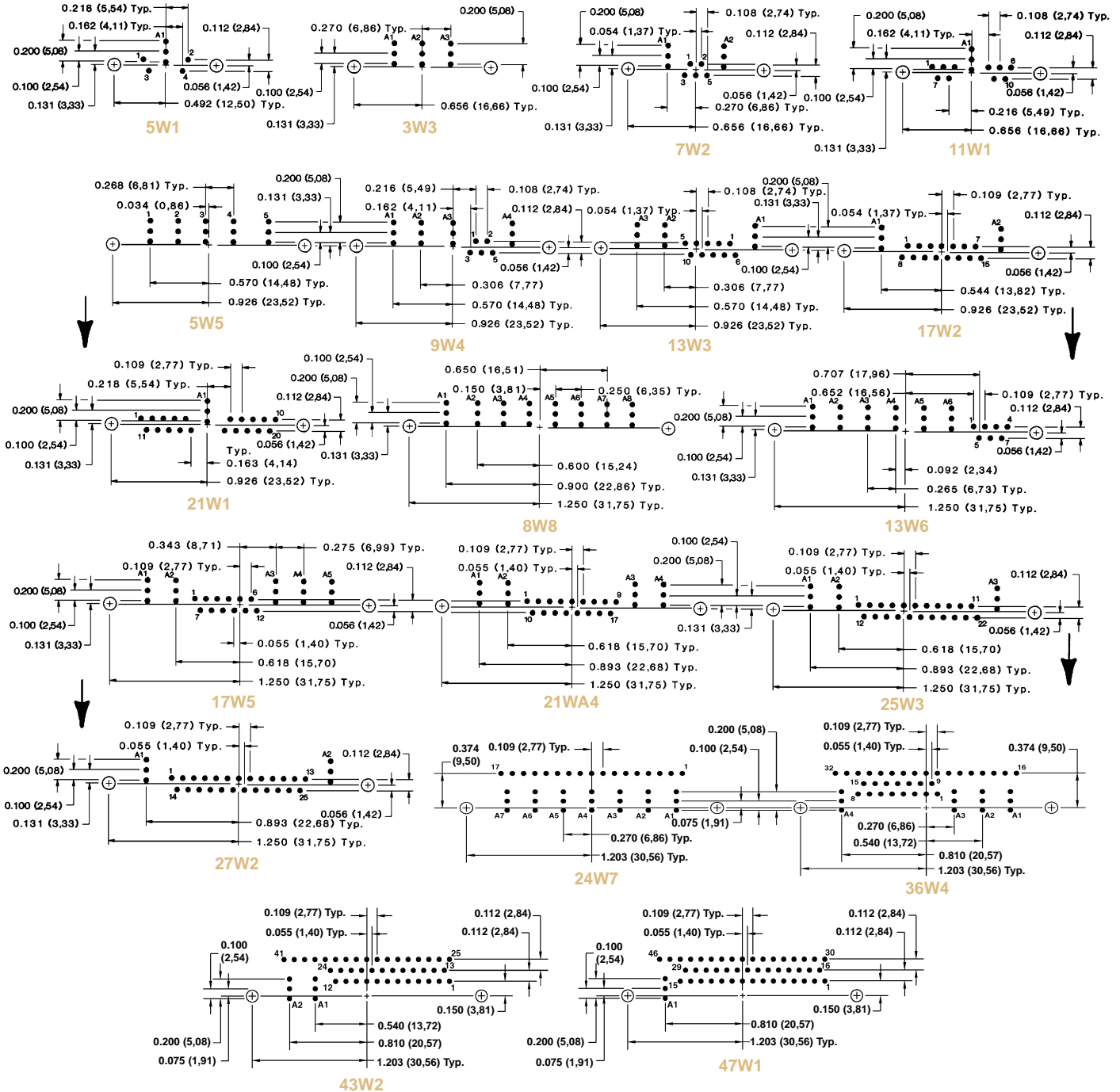

Suggest 0.045(1.14) Ø hole for signal contact termination position.  
Suggest 0.123 ±0.003 (3.12) Ø hole for mounting connector with push-on fastener.

DIMENSIONS ARE IN INCHES (MILLIMETERS).  
ALL DIMENSIONS ARE SUBJECT TO CHANGE.

### ORDERING INFORMATION - CODE NUMBERING SYSTEM

Specify the complete connector by following Steps 1 through 9.  
Insert "0" when a step is not used.

STEP	1	2	3	4	5	6	7	8	9
	SCBM	17W2	F	55	R7	N	T2	G	

#### STEP 1 - Basic Series

SCBM Series - Space Conformance with  
"Closed Entry" Signal Contacts

#### STEP 2 - Space Combo-D Series Connector Variants

##### Shell Size 1

5W1

##### Shell Size 2

3W3, 7W2, 11W1

##### Shell Size 3

5W5, 9W4, 13W3, 17W2, 21W1

##### Shell Size 4

8W8, 13W6, 17W5, 21WA4, 25W3, 27W2

##### Shell Size 5

24W7, 36W4, 43W2, 47W1

##### Shell Size 6

46W4

#### STEP 3 - Connector Gender

M -Male

F -Female

#### STEP 4 - Contact Termination Type

- 2 - Solder, Signal Contacts only.
- 3 - Solder, Straight Printed Board Mount with Signal Contacts, 0.170(4.32) Tail Length.
- 35 - Solder, Straight Printed Board Mount with Signal and 0.078(1.98) Ø Power Contacts, 0.170(4.32) Tail Length.
- 37 - Solder, Straight Printed Board Mount with Signal and 0.125(3.18) Ø Power Contacts, 0.170(4.32) Tail Length.
- 5 - Solder, 90° Printed Board Mount with Signal Contacts only, 0.283(7.19) Signal Contact Extension.
- 55 - Solder, 90° Printed Board Mount with Signal and 0.078(1.98) Ø Power Contacts, 0.283(7.19) Signal Contact Extension.
- 57 - Solder, 90° Printed Board Mount with Signal and 0.125(3.18) Ø Power Contacts, 0.283(7.19) Signal Contact Extension.
- 65 - Solder, Straight Printed Board Mount with Signal and Shielded Contacts, MDS/FDS 4201M footprint, 0.170(4.32) Signal Contact Tail Length.
- 7 - Solder, Metric System 90° Printed Board Mount with Signal Contacts only, 0.370(9.40) Signal Contact Extension.
- 75 - Solder, Metric System 90° Printed Board Mount with Signal and 0.078(1.98) Ø Power Contacts, 0.370(9.40) Signal Contact Extension.
- 77 - Solder, Metric System 90° Printed Board Mount with Signal and 0.125(3.18) Ø Power Contacts, 0.370(9.40) Signal Contact Extension.
- \*\*85 - Solder, 90° Printed Board Mount with Signal and Shielded Contacts, MRT/FRT 4201M Footprint, 0.283(7.19) Signal Contact Extension.

#### STEP 9 - Special Options

Consult Sales Department.

#### STEP 8 - Shell Options

G - Gold over Copper Plate.

D - Gold over Copper Plate and Dimpled.

#### \* STEP 7 - Locking and Polarizing Systems

- 0 - None.
- T - Fixed Female Jackscrews.
- T2 - Fixed Female Jackscrews.
- T6 - Fixed Male and Female Polarized Jackscrews.
- E - Rotating Male Jackscrews.
- E6 - Rotating Male and Female Polarized Jackscrews.

#### \* STEP 6 - Hoods and Push-On Fasteners

- 0 - None.
- H - Hood, Top Opening, Brass.
- M - Hood, Top Opening, Aluminum, see page 52 for complete listing of options.
- N - Push-on Fastener for 90° Mounting Brackets.

#### \* STEP 5 - Mounting Style

- 0 - Mounting Hole, 0.120(3.05) Ø.
- B3 - Bracket, Mounting, 90° Metal with Cross Bar.
- F - Float Mounts, Universal.
- P - Threaded Post, Brass, 0.250(6.35) Length.
- R2 - Bracket, Mounting, 90° Metal, Swaged to Connector with 4-40 Thread Fixed Female Jackscrews with Cross Bar.
- R6 - Bracket, Mounting, 90° Metal, Swaged to Connector with 0.120(3.05) Ø Mounting Hole with Cross Bar.
- R7 - Bracket, Mounting, 90° Metal, Swaged to Connector with 4-40 Threads with Cross Bar.
- R8 - Bracket, Mounting, 90° Metal, Swaged to Connector with 4-40 Locknut with Cross Bar.
- S - Swaged Spacer, 4-40 Threads, 0.250(6.35) Length.
- S2 - Swaged Spacer, 4-40 Threads, 0.125(3.18) Length.
- S5 - Swaged Locknut, 4-40 Threads.
- S6 - Swaged Spacer with Push-on Fastener, 4-40 Threads, 0.250(6.35) Length.

#### \* NOTE:

For additional information on accessories listed in Steps 5, 6, and 7, see the Accessory Section, pages 48-54.

#### \*\* NOTE:

Not available on Shell Size 6, CBD 46W4.

**REMOVABLE POWER CONTACTS  
SOLDER POWER CONTACTS**

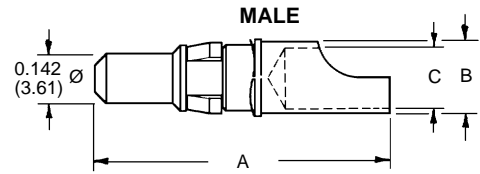
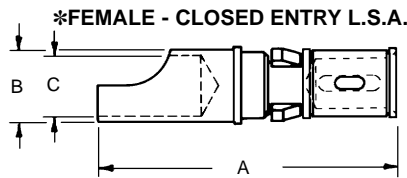
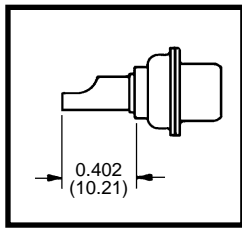

Solder contacts may be supplied kitted with connector or ordered separately.

PART NUMBER	CURRENT RATING	WIRE SIZE	A REF.	B Ø	C Ø
FS4008M	40 AMPS	8	0.858 (21.79)	0.219 (5.56)	0.188 (4.78)
FS4012M	20 AMPS	12	0.858 (21.79)	0.143 (3.63)	0.112 (2.84)
FS4016M	10 AMPS	16	0.858 (21.79)	0.100 (2.54)	0.069 (1.75)

PART NUMBER	CURRENT RATING	WIRE SIZE	A REF.	B Ø	C Ø
MS4008M	40 AMPS	8	0.868 (22.05)	0.219 (5.56)	0.188 (4.78)
MS4012M	20 AMPS	12	0.868 (22.05)	0.143 (3.63)	0.112 (2.84)
MS4016M	10 AMPS	16	0.868 (22.05)	0.100 (2.54)	0.069 (1.75)

**Material:** High conductivity copper alloy.

**Plating:** 0.000050 inch (1.25 µ) gold over copper.

**REMOVABLE CRIMP CONTACTS  
POWER CONTACTS**

Crimp power contacts may be supplied with connector or ordered separately.

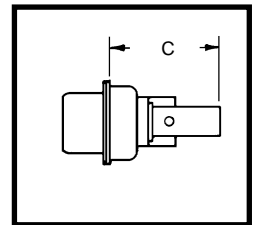
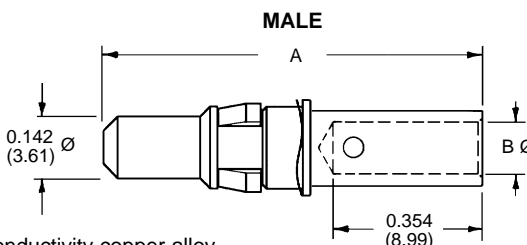
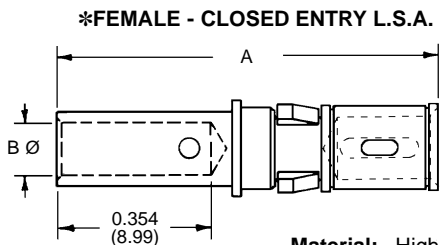

**Material:** High conductivity copper alloy.

**Plating:** 0.000050 inch (1.25 µ) gold over copper.

PART NUMBER	CURRENT RATING	WIRE SIZE	A REF.	B Ø	C MAX.
FC4008M	40 AMPS	8	0.858 (21.79)	0.181 (4.60)	0.640 (16.26)
FC4012M	20 AMPS	12	0.858 (21.79)	0.101 (2.57)	0.640 (16.26)
FC4016M	10 AMPS	16	0.858 (21.79)	0.067 (1.70)	0.640 (16.26)

PART NUMBER	CURRENT RATING	WIRE SIZE	A REF.	B Ø	C MAX.
MC4008M	40 AMPS	8	0.882 (22.40)	0.181 (4.60)	0.640 (16.26)
MC4012M	20 AMPS	12	0.882 (22.40)	0.101 (2.57)	0.640 (16.26)
MC4016M	10 AMPS	16	0.882 (22.40)	0.067 (1.70)	0.640 (16.26)

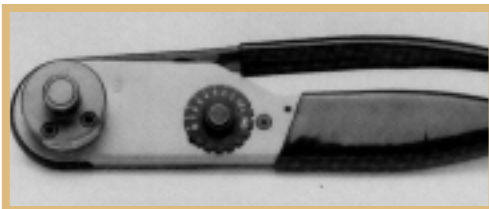

9509-0-0 Power Contact Hand Crimp Tool  
For use with \*C4012M and \*C4016M Contacts

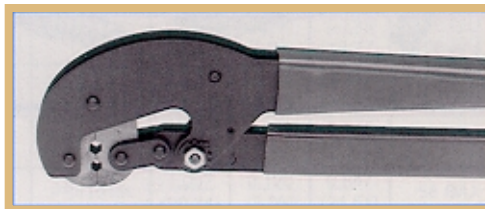

9504-17 Power Contact Hand Crimp Tool  
For use with \*C4008M Contacts

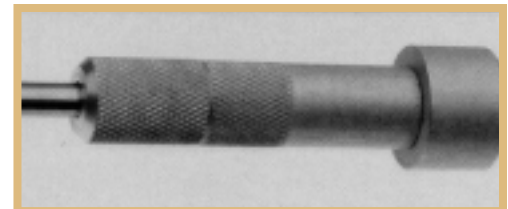

4311-0-0 Power Contact Removal Tool

\*NOTE: Female contacts feature Large Surface Area (L.S.A.) "Closed Entry" contact design which provides maximum mating surfaces between male and female contact and reduced contact resistance during operation.

DIMENSIONS ARE IN INCHES (MILLIMETERS).  
ALL DIMENSIONS ARE SUBJECT TO CHANGE.

**REMOVABLE HIGH VOLTAGE CONTACTS**

High voltage contacts are not supplied with connectors and must be ordered separately.

**STRAIGHT SOLDER WIRE TERMINATION**

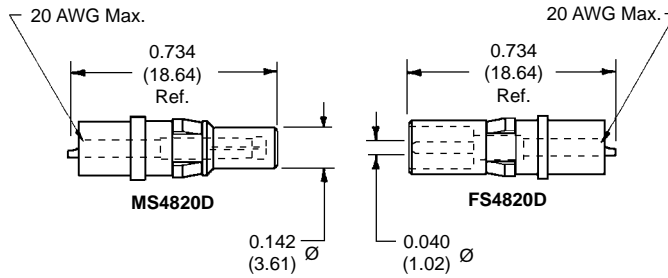
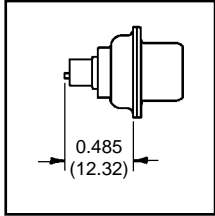

**90° SOLDER WIRE TERMINATION**

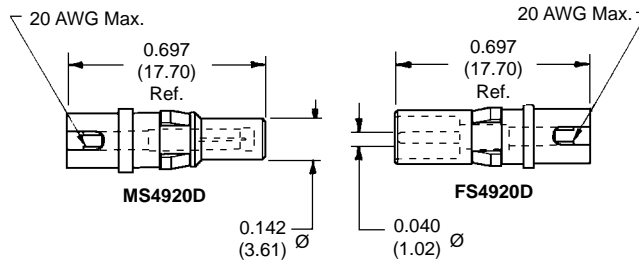
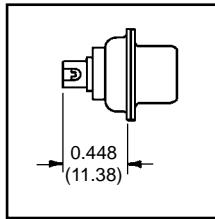

**TECHNICAL CHARACTERISTICS**

**MATERIALS AND FINISHES:**

**Insulators:** Teflon, PTFE.  
**Contacts:** Male contacts, brass. Female contacts, phosphor bronze.  
**Plating:** 0.000050 inch (1.25 microns) gold over copper.

**MECHANICAL CHARACTERISTICS:**

**Size 8 Removable Contacts:** Rear insertion, front release.  
**Durability:** 500 cycles minimum.  
**Vibration:** 20g from 10 Hz to 500 Hz.  
**Shock:** 30g-11ms.

**ELECTRICAL CHARACTERISTICS:**

**HIGH VOLTAGE CONTACTS**  
**Flash Over Voltage:** 3600 V r.m.s.  
**Proof Voltage:** 2700 V r.m.s.  
**Initial Contact Resistance:** 0.008 ohms maximum.

**CLIMATIC CHARACTERISTICS:**

**Temperature Range:** -55°C to +125°C.

**SHIELDED CONTACTS  
TECHNICAL CHARACTERISTICS**

**MATERIALS AND FINISHES:**

**Insulating Material:** (Dielectric) Teflon, PTFE.  
**Inner Contacts:** Brass and Phosphor Bronze, 0.000050 inch (1.25 microns) gold over copper.  
**Outer Contacts:** Brass and Phosphor Bronze, 0.000050 inch (1.25 microns) gold over copper.

**MECHANICAL CHARACTERISTICS:**

**Removable Contacts:** Rear Insertion, front release.  
**Durability:** 500 cycles, minimum.  
**Vibration:** 20g from 10 HZ to 500 HZ.  
**Shock:** 30g - 11 ms.

**ELECTRICAL CHARACTERISTICS:**

**Initial Contact Resistance:** 0.008 ohms, maximum.  
**\* Nominal Impedance:** 50 ohms.  
**\* Insertion Loss:** -0.46 dB at 1 GHz  
 -1.5 dB at 2 GHz  
**\* VSWR:** 1.15 average at 1 GHz  
 1.56 average at 2 GHz  
**Proof Voltage:** 1,000 V r.m.s.  
**\* Above values measured using frequency domain techniques.**

**CLIMATIC CHARACTERISTICS:**

**Temperature Range:** -55°C to +125°C.



**REMOVABLE SHIELDED CONTACTS**

Shielded contacts may be supplied kitted with connector or ordered separately.

**STRAIGHT SOLDER/CRIMP CONTACTS**

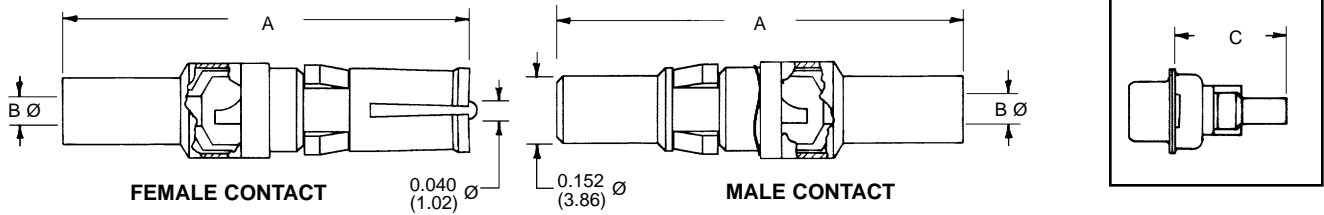

**STRAIGHT SOLDER/SOLDER CONTACTS**

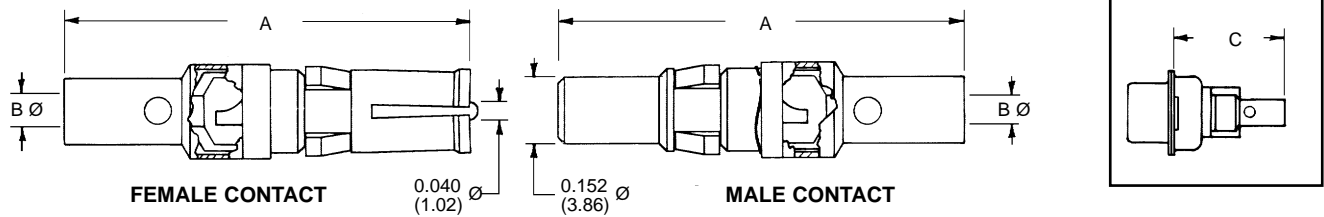

**STRAIGHT CRIMP/CRIMP CONTACTS**

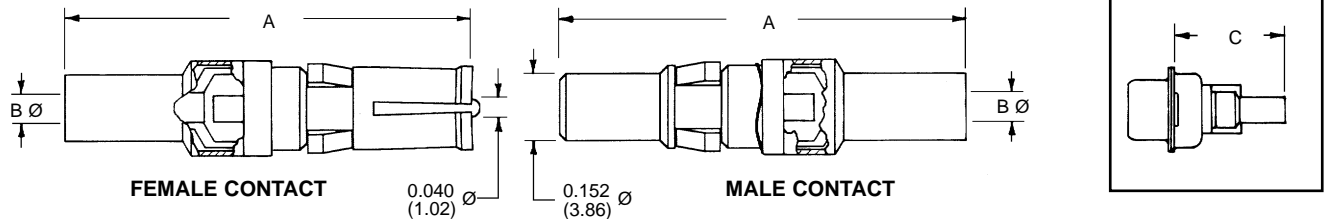

**Material:** Copper alloy with PTFE teflon insulator.

**Signal Contact Plating:** 0.000050 inch (1.25 μ) gold over copper.

**Contact Body Plating:** 0.000050 inch (1.25 μ) gold over copper.

TYPE OF CONTACT	PART NUMBER		A	B Ø	C MAX.	RG CABLE NUMBER
	MALE	FEMALE				
SOLDER/CRIMP	MC4101M	FC4101M	0.929 (23.60)	0.040 (1.02)	0.739 (18.77)	178 B/U 196 B/U
	MC4102M	FC4102M	0.929 (23.60)	0.067 (1.70)	0.739 (18.77)	179 B/U 316 /U
SOLDER/CRIMP	MC4103M	FC4103M	1.037 (26.34)	0.108 (2.74)	0.847 (21.51)	180 B/U
	MC4104M	FC4104M	1.037 (26.34)	0.120 (3.05)	0.847 (21.51)	58 B/U
SOLDER/SOLDER	MS4101M	FS4101M	0.929 (23.60)	0.040 (1.02)	0.739 (18.77)	178 B/U 196 B/U
	MS4102M	FS4102M	0.929 (23.60)	0.067 (1.70)	0.739 (18.77)	179 B/U 316 /U
SOLDER/SOLDER	MS4103M	FS4103M	1.037 (26.34)	0.108 (2.74)	0.847 (21.51)	180 B/U
	MS4104M	FS4104M	1.037 (26.34)	0.120 (3.05)	0.847 (21.51)	58 B/U
CRIMP/CRIMP	MCC4101M	FCC4101M	0.929 (23.60)	0.040 (1.02)	0.739 (18.77)	178 B/U 196 B/U
	MCC4102M	FCC4102M	0.929 (23.60)	0.067 (1.70)	0.739 (18.77)	179 B/U 316 /U
CRIMP/CRIMP	MCC4103M	FCC4103M	1.037 (26.34)	0.108 (2.74)	0.847 (21.51)	180 B/U
	MCC4104M	FCC4104M	1.037 (26.34)	0.120 (3.05)	0.847 (21.51)	58 B/U

Two-step crimping action for signal and shielding conductors.

See page 35 for crimp tool and crimping information.

DIMENSIONS ARE IN INCHES (MILLIMETERS). ALL DIMENSIONS ARE SUBJECT TO CHANGE.

**SOLDERING AND CRIMPING INFORMATION  
FOR SCBC AND SCBM SERIES SHIELDED CONTACTS**

**STEP 1: STRIP WIRE TO INDICATED LENGTH.**

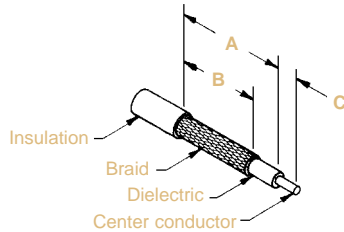

**TAKE CARE NOT TO:**

- Damage or remove strands.
- Untwist or overtighten strands.
- Leave insulation particles on strands.
- Damage insulation.

PART NUMBER	RG CABLE NUMBER	A	B	C	CRIMP TOOL
*C4101M *S4101M	178 B/U	0.281 (7.14)	0.250 (6.35)	0.078 (1.98)	9504-0
*C4102M *S4102M	179 B/U 316 /U	0.281 (7.14)	0.250 (6.35)	0.078 (1.98)	9504-0
*C4103M *S4103M	180 B/U	0.375 (9.53)	0.312 (7.92)	0.078 (1.98)	9504-0
*C4104M *S4104M	58 B/U	0.375 (9.53)	0.312 (7.92)	0.078 (1.98)	9504-0
*CC4101M	178 B/U	0.281 (7.14)	0.250 (6.35)	0.120 (3.05)	9504-14
*CC4102M	179 B/U 316 /U	0.281 (7.14)	0.250 (6.35)	0.120 (3.05)	9504-13
*CC4103M	180 B/U	0.375 (9.53)	0.312 (7.92)	0.120 (3.05)	9504-15
*CC4104M	58 B/U	0.375 (9.53)	0.312 (7.92)	0.120 (3.05)	9504-15

\* Contact gender is designated by M for male contacts and F for female contacts.

Typical Part Number:  
FC4101M

**STEP 2: CRIMP WIRE TO CONTACT.**

- Trim cable.
- Slide ferrule over jacket. Insert dielectric and center conductor into barrel. Crimp center conductor into contact.
- Butt ferrule against shoulder. Crimp ferrule over braid.

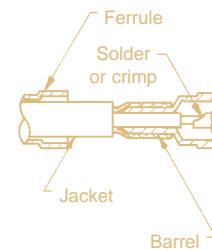

**STEP 2: SOLDER WIRE TO CONTACT.**

- Trim cable. Tin center conductor.
- Slide ferrule over jacket. Insert dielectric and center conductor into barrel. Solder center conductor into contact.
- Butt ferrule against shoulder. Solder cable to barrel through hole in ferrule. Solder cap into body.

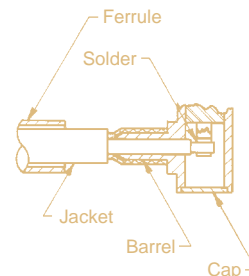

**STEP 2: SOLDER/CRIMP WIRE TO CONTACT.**

- Trim cable. Tin center conductor.
- Slide ferrule over jacket. Insert dielectric and center conductor into barrel. Solder center conductor into contact.
- Butt ferrule against shoulder. Crimp ferrule over braid. Solder cap into body.



**Shielded Contact Hand Crimp Tool**  
See Chart above for Crimp Tool Part Numbers.

DIMENSIONS ARE IN INCHES (MILLIMETERS).  
ALL DIMENSIONS ARE SUBJECT TO CHANGE.

# SCBC SERIES

## SPACE FLIGHT APPLICATION, COMBINATION CONTACT SUBMINIATURE-D CONNECTORS CRIMP REMOVABLE CONTACT SERIES

Size 20 Signal Contacts,  
Crimp Removable

Size 8 Shielded and  
Power Crimp  
Removable Contacts

Space Application  
Quality Connectors

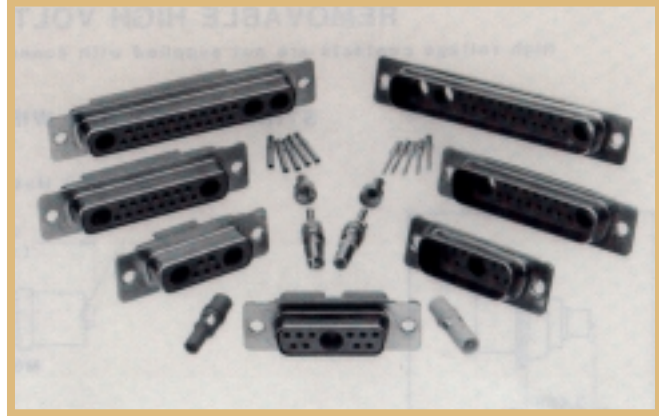

Space Combination Contact Subminiature-D connectors, Series SCBC, are space flight application quality rectangular connectors designed especially to withstand the rigors of launch and subsequent space flight. The SCBC Series features crimp removable Size 20 signal contacts and Size 8 power and shielded contacts.

The materials, dimensions, and performance of the SCBC Series conform to the requirements of DESC drawing 85039 and GSFC S-311-P-405 where applicable. The SCBC Series fully complies to the outgassing requirements of ASTM E-595 and NASA-RP-1124.

The SCBC Series utilizes precision machined contacts with the female contact featuring a "Closed-Entry" design having a brass protective shroud.

Eleven standard combination contact variants are available, utilizing six shell sizes. All connector variants of the SCBC Series are plug compatible with equivalent SCBM printed board mounted or panel mounted connectors.

Nonmagnetic cable supports and jackscrew systems are available.

Visual and mechanical inspection per MIL-DTL-24308 is performed, additional testing is available. Contact Technical Sales.

### \*SCBC SERIES CONTACT VARIANTS

FACE VIEW OF MALE OR REAR VIEW OF FEMALE

**\* NOTE:**  
Additional contact variants may  
be tooled at customer request.

#### SHELL SIZE 1

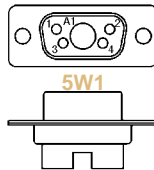

#### SHELL SIZE 2

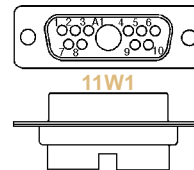
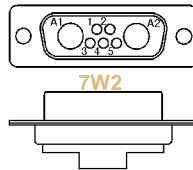

#### SHELL SIZE 3

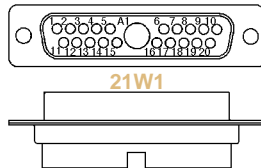
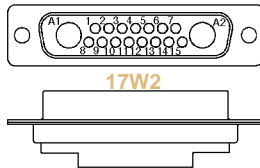
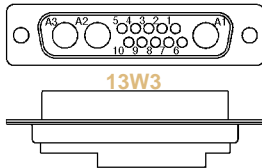

#### SHELL SIZE 4

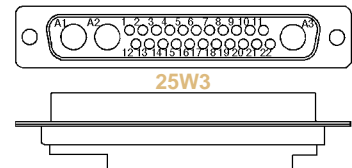

#### SHELL SIZE 5

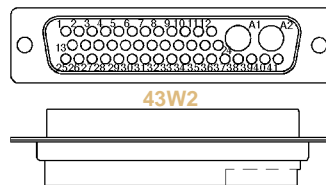
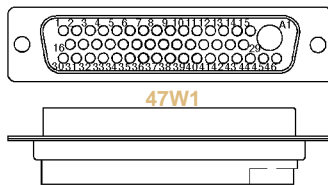
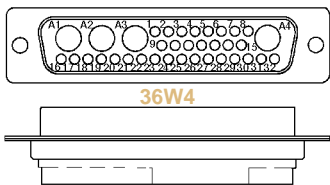

#### SHELL SIZE 6

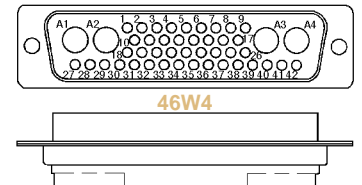

### SCBC SERIES TECHNICAL CHARACTERISTICS

#### MATERIALS AND FINISHES:

<b>Insulator:</b>	Glass-filled polyester per MIL-M-24519, UL 94V-0, ASTM E-595, NASA-RP-1124, blue color.
<b>Contacts:</b>	<b>Male Contacts:</b> Precision machined brass alloy. <b>Female Contacts:</b> Precision machined high tensile copper alloy with brass shroud; "Closed Entry" design.
<b>Signal Contact Plating:</b>	0.000050 inch (1.25 microns) gold over copper plate.
<b>Power Contacts:</b>	Machined of high conductivity copper alloy for both male and female contacts.
<b>Power Contact Plating:</b>	0.000050 inch (1.25 microns) gold over copper plate.
<b>Shielded Contacts:</b>	Precision-machined copper alloy male contacts and female contacts. Retainers of beryllium copper.
<b>Shielded Contact Plating:</b>	<b>Signal Contact Plating:</b> 0.000050 inch (1.25 microns) gold over copper. <b>Shielded Body Plating:</b> 0.000050 inch (1.25 microns) gold over copper.
<b>Shells:</b>	Brass with 0.000050 inch (1.25 microns) gold over copper plate.
<b>Mounting Spacers:</b>	Brass with 0.000050 inch (1.25 microns) gold over copper plate.
<b>Jackscrew Systems:</b>	Brass with 0.000050 inch (1.25 microns) gold over copper plate.
<b>Hoods:</b>	Brass with 0.000050 inch (1.25 microns) gold over copper plate or aluminum with yellow chromate conversion or black anodize finish.

#### ELECTRICAL CHARACTERISTICS:

##### SIGNAL CONTACTS

<b>Contact Current Rating:</b>	7.5 amperes, nominal.
<b>Initial Contact Resistance:</b>	0.008 ohms, maximum.
<b>Proof Voltage:</b>	1,000 V r.m.s.

##### POWER CONTACTS

<b>Contact Current Rating:</b>	10, 15, 20, 30, and 40 amperes, nominal.
<b>Initial Contact Resistance:</b>	0.005 ohms, maximum.
<b>Proof Voltage:</b>	1,000 V r.m.s.

##### SHIELDED CONTACTS

<b>Initial Contact Resistance:</b>	0.008 ohms, maximum.
<b>Nominal Impedance:</b>	50 ohms.
<b>Insertion Loss:</b>	-0.46 dB at 1 GHz. -1.5 dB at 2 GHz.

##### VSWR:

	1.15 average at 1 GHz.
	1.56 average at 2 GHz.

Above values measured using frequency domain techniques.

**Proof Voltage:** 1,000 V r.m.s.

##### CONNECTORS

<b>Insulator Resistance:</b>	5 G ohms.
<b>Clearance and Creepage Distance:</b>	0.039 inch (1.0 mm), minimum.
<b>Working Voltage:</b>	300 V r.m.s.
<b>Residual Magnetism:</b>	20 Gamma, maximum.

#### MECHANICAL CHARACTERISTICS:

<b>Signal Contacts, Crimp Removable:</b>	Size 20 contact. <b>Male Contact:</b> 0.040 inch (1.02 mm) diameter. <b>Female Contact:</b> Closed entry design with brass shroud.
<b>Contact Retention in Insulator:</b>	9 lbs. (40 N). Power and shielded - 22 lbs. (98 N).
<b>Crimp Contact Terminations:</b>	Closed barrel crimp, wire sizes 20 AWG (1.0 mm <sup>2</sup> ) through 30 AWG (0.05 mm <sup>2</sup> ).
<b>Power Contacts, Removable, Crimp or Solder Terminations:</b>	Size 8 contacts. <b>Male Contact:</b> 0.142 inch (3.61 mm) diameter. <b>Female Contact:</b> Features Large Surface Area (L.S.A.) Closed entry design utilizing BeCu mechanical retention member. Male and female contacts have terminations for wire sizes 8, 12, and 16 AWG.
<b>Shielded Contacts, Removable:</b>	See table of maximum cable sizes for contact termination dimensions, pages 34 and 35.
<b>Shells:</b>	Male shells may be dimpled for EMI/ESD ground paths.
<b>Polarization:</b>	Trapezoidally shaped shells and polarized jackscrews.
<b>Locking Systems:</b>	Jackscrews.
<b>Mechanical Operations, Signal Contacts:</b>	SCBC Series, 1,000 operations, closed entry contact with 0.000050 (1.25 microns) gold plating per IEC 512-5.

#### CLIMATIC CHARACTERISTICS:

<b>Temperature Range:</b>	-55°C to +125°C.
<b>Damp Heat, Steady State:</b>	21 days.

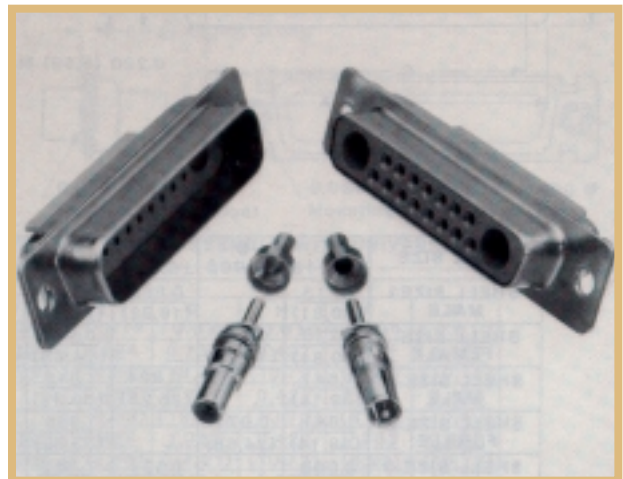

SCBC17W2M0000G  
WITH MC4101M

SCBC17W2F0000G  
WITH FC4101M

DIMENSIONS ARE IN INCHES (MILLIMETERS).  
ALL DIMENSIONS ARE SUBJECT TO CHANGE.



SCBC7W2F0000G

SCBC17W2M0000G

### STANDARD SHELL ASSEMBLY

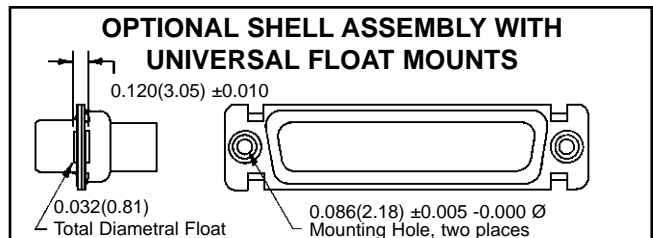
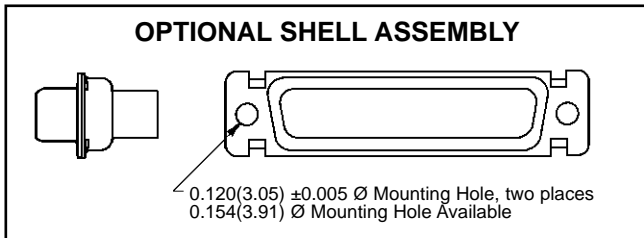
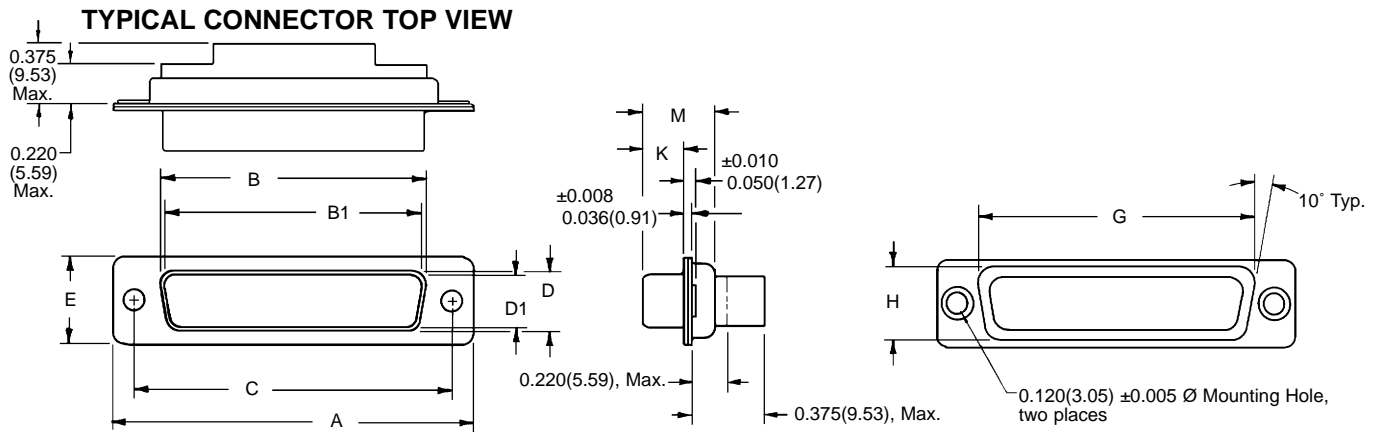

SHELL SIZE	A ±0.015	B ±0.005	B1 ±0.005	C ±0.005	D ±0.005	D1 ±0.005	E ±0.015	G ±0.010	H ±0.010	K ±0.005	M ±0.010
SHELL SIZE 1 MALE	1.213 (30.81)		0.666 (16.92)	0.984 (24.99)		0.329 (8.36)	0.494 (12.55)	0.759 (19.28)	0.422 (10.72)	0.233 (5.92)	0.422 (10.72)
SHELL SIZE 1 FEMALE	1.213 (30.81)	0.643 (16.33)		0.984 (24.99)	0.311 (7.90)		0.494 (12.55)	0.759 (19.28)	0.422 (10.72)	0.243 (6.17)	0.429 (10.90)
SHELL SIZE 2 MALE	1.541 (39.14)		0.994 (25.25)	1.312 (33.32)		0.329 (8.36)	0.494 (12.55)	1.083 (27.51)	0.422 (10.72)	0.233 (5.92)	0.422 (10.72)
SHELL SIZE 2 FEMALE	1.541 (39.14)	0.971 (24.66)		1.312 (33.32)	0.311 (7.90)		0.494 (12.55)	1.083 (27.51)	0.422 (10.72)	0.243 (6.17)	0.429 (10.90)
SHELL SIZE 3 MALE	2.088 (53.04)		1.534 (38.96)	1.852 (47.04)		0.329 (8.36)	0.494 (12.55)	1.625 (41.28)	0.422 (10.72)	0.230 (5.84)	0.426 (10.82)
SHELL SIZE 3 FEMALE	2.088 (53.04)	1.511 (38.38)		1.852 (47.04)	0.311 (7.90)		0.494 (12.55)	1.625 (41.28)	0.422 (10.72)	0.243 (6.17)	0.429 (10.90)
SHELL SIZE 4 MALE	2.729 (69.32)		2.182 (55.42)	2.500 (63.50)		0.329 (8.36)	0.494 (12.55)	2.272 (57.71)	0.422 (10.72)	0.230 (5.84)	0.426 (10.82)
SHELL SIZE 4 FEMALE	2.729 (69.32)	2.159 (54.84)		2.500 (63.50)	0.311 (7.90)		0.494 (12.55)	2.272 (57.71)	0.422 (10.72)	0.243 (6.17)	0.429 (10.90)
SHELL SIZE 5 MALE	2.635 (66.93)		2.079 (52.81)	2.406 (61.11)		0.441 (11.20)	0.605 (15.37)	2.178 (55.32)	0.534 (13.56)	0.230 (5.84)	0.426 (10.82)
SHELL SIZE 5 FEMALE	2.635 (66.93)	2.064 (52.43)		2.406 (61.11)	0.423 (10.74)		0.605 (15.37)	2.178 (55.32)	0.534 (13.56)	0.243 (6.17)	0.429 (10.90)
SHELL SIZE 6 MALE	2.729 (69.32)		2.212 (56.18)	2.500 (63.50)		0.503 (12.78)	0.668 (16.97)	2.302 (58.47)	0.596 (15.14)	0.230 (5.84)	0.426 (10.82)
SHELL SIZE 6 FEMALE	2.729 (69.32)	2.189 (55.60)		2.500 (63.50)	0.485 (12.32)		0.668 (16.97)	2.302 (58.47)	0.596 (15.14)	0.243 (6.17)	0.429 (10.90)

DIMENSIONS ARE IN INCHES (MILLIMETERS). ALL DIMENSIONS ARE SUBJECT TO CHANGE.



**CRIMP REMOVABLE CONTACT CONNECTOR  
SIGNAL CRIMP CONTACTS  
CLOSED CRIMP BARREL**

**FEMALE CONTACT ("CLOSED ENTRY" DESIGN)**

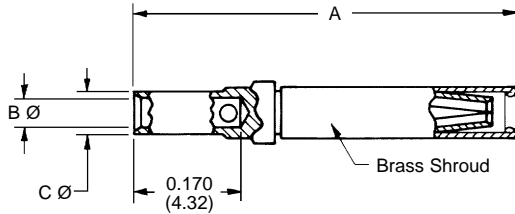

**Contact Material:** Leaded nickel copper.  
**Plating:** 0.000050 inch (1.25 μ) gold over copper.

**MALE CONTACT**

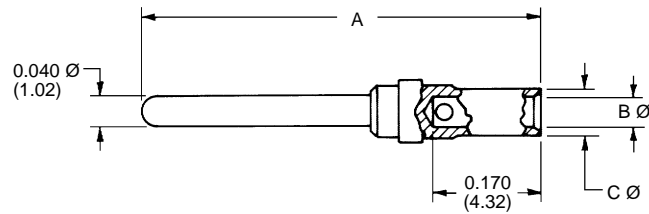

**Material:** Brass.  
**Plating:** 0.000050 inch (1.25 μ) gold over copper.

PART NUMBER	WIRE SIZE AWG/(mm <sup>2</sup> )	A	B Ø	C Ø
FC6020D-50-1202.1	20 / 22 / 24 (0.5/0.3/0.25)	0.538 (13.67)	0.044 (1.12)	0.066 (1.68)
FC6026D-50-1202.1	26 / 28 / 30 (0.12/0.08/0.05)	0.538 (13.67)	0.027 (0.69)	0.066 (1.68)

PART NUMBER	WIRE SIZE AWG/(mm <sup>2</sup> )	A	B Ø	C Ø
MC6020D-50	20 / 22 / 24 (0.5/0.3/0.25)	0.550 (13.97)	0.044 (1.12)	0.066 (1.68)
MC6026D-50	26 / 28 / 30 (0.12/0.08/0.05)	0.550 (13.97)	0.027 (0.69)	0.066 (1.68)

Crimp contacts may be supplied kitted with connector or ordered separately.

**FEMALE CONTACT ("CLOSED ENTRY" DESIGN)  
18 AWG (1.0mm<sup>2</sup>) max.**

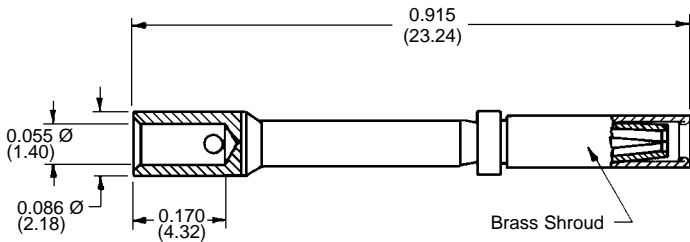

**Part number: FC6018M**

**Material:** Leaded nickel copper.  
**Plating:** 0.000050 inch (1.25 μ) gold over copper.

**MALE CONTACT  
18 AWG (1.0mm<sup>2</sup>) max.**

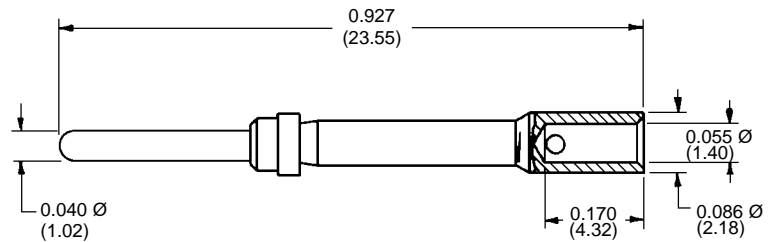

**Part number: MC6018M**

**Material:** Brass.  
**Plating:** 0.000050 inch (1.25 μ) gold over copper.

**REELS FOR AUTOMATIC FEED PNEUMATIC CRIMP TOOLS**

Contacts may be supplied in plastic carriers, packaged in reels holding 2,000 contacts for use with the automatic feed pneumatic crimp tools, catalog part number 9550-1. The same type carrier is used for both male and female contacts.

All male and female crimp contacts can be ordered in reels by adding letter "R" after the contact part number, such as MC6020DR-50 for a male contact and FC6026DR-50-1202.1 for female contact.

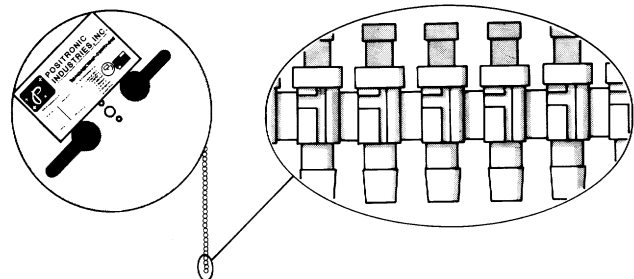

**Enlarged section of plastic contact carriers**

**For SCBC crimping information and crimp tools, see pages 39, 40, 41 and 43.**

**DIMENSIONS ARE IN INCHES (MILLIMETERS).  
ALL DIMENSIONS ARE SUBJECT TO CHANGE.**

**CRIMPING INFORMATION FOR SND AND SCBC SERIES CRIMP SIGNAL CONTACTS  
CRIMP REMOVABLE CONTACT CONNECTOR**

**USE INDICATED POSITRONIC TOOLS FOR BEST RESULTS**

**Step 1: Strip wire to indicated length.**

- Take Care Not To:**
- Damage or remove strands.
  - Untwist or overtwist strands.
  - Leave insulation particles on strands.
  - Damage insulation.

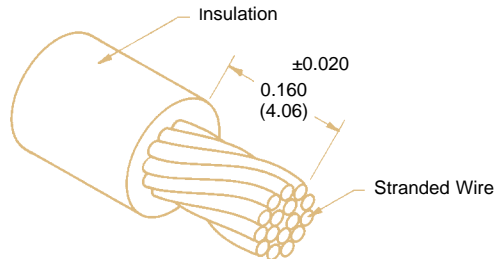

**Correctly Stripped Wire**

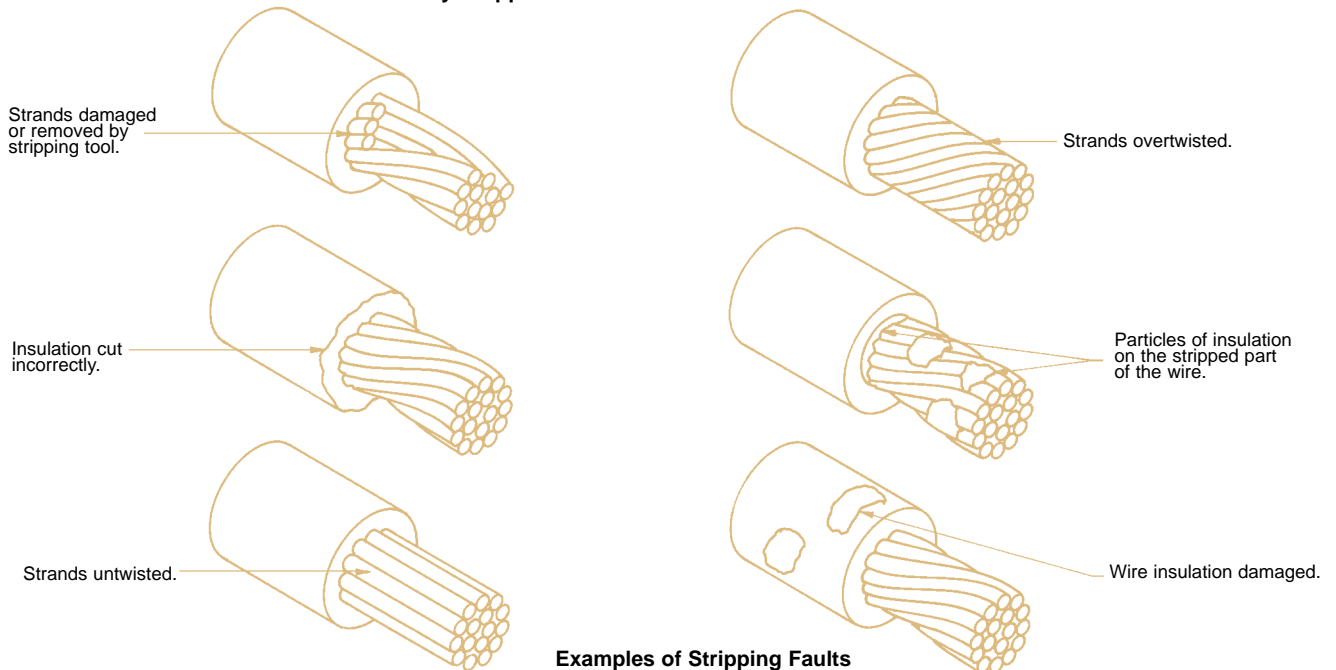

**Examples of Stripping Faults**

**Step 2: Crimp wire to contact.**

- For Hand Crimp Tool:**
- Place contact into crimping tool.
  - Insert wire into contact.
  - Center contact by slowly closing the crimping tool until the crimp indenters make contact with the crimp barrel.
  - Complete the cycle of the crimping tool in one smooth motion.
  - Remove the crimped contact.

- For Automatic Feed Pneumatic Crimp Tool:**
- Insert the wire into the contact, positioned in the crimp tool by the plastic carrier.
  - Depress the activating device of the crimping tool to start the crimping cycle.
  - Remove the crimped contact.

DIMENSIONS ARE IN INCHES (MILLIMETERS).  
ALL DIMENSIONS ARE SUBJECT TO CHANGE.

### CRIMPING INFORMATION FOR SND AND SCBC SERIES CRIMP SIGNAL CONTACTS CRIMP REMOVABLE CONTACT CONNECTOR

#### Step 3: Inspect the crimp.

- For All Tools: - Strands to be visible through the inspection hole.  
 - Strands not to be visible beyond the insulation support.  
 - Crimped contact to meet recommended conductor tensile force shown in chart.  
 - Check for peeled gold and bent contacts.

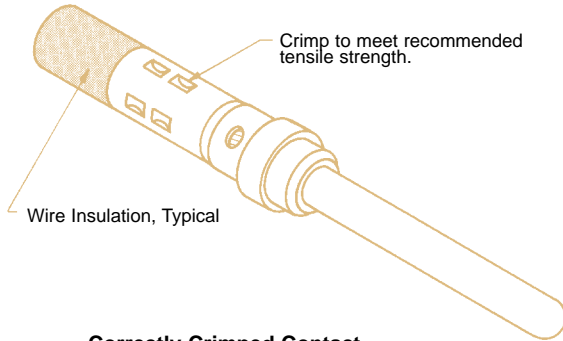

Correctly Crimped Contact

Cross Section of Correctly Crimped Contact

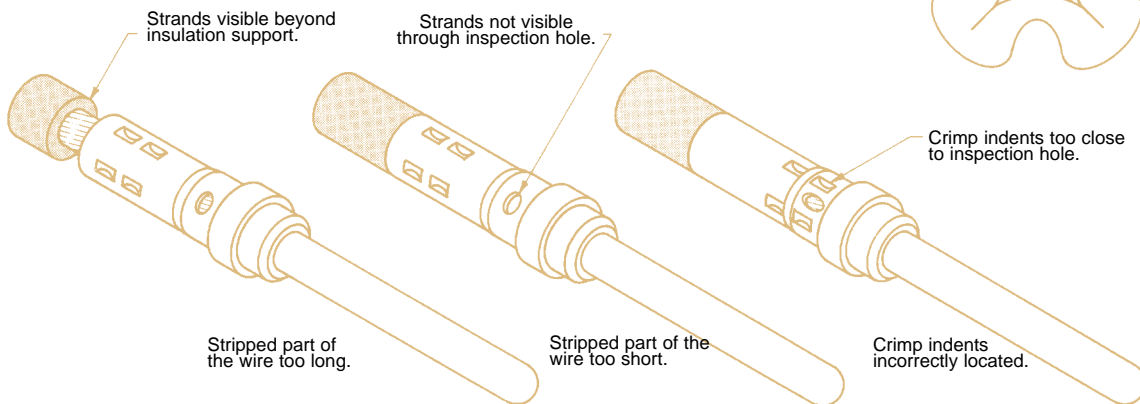
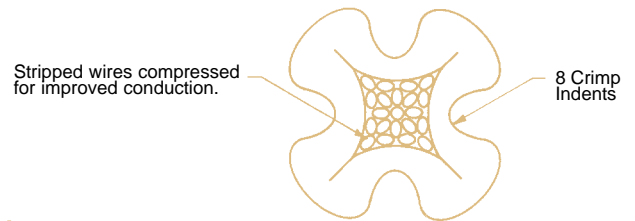

Examples of Crimping Faults

Positronic Recommended  
Conductor Tensile Strength

WIRE SIZE AWG/(mm <sup>2</sup> )	AXIAL LOAD POUNDS/(N)
$\frac{20}{(0.5)}$	$\frac{20}{(89)}$
$\frac{22}{(0.3)}$	$\frac{12}{(53)}$
$\frac{24}{(0.25)}$	$\frac{8}{(36)}$
$\frac{26}{(0.12)}$	$\frac{5}{(22)}$
$\frac{28}{(0.08)}$	$\frac{3}{(13)}$
$\frac{30}{(0.05)}$	$\frac{1.5}{(6.7)}$

Conductor tensile strength values are derived using silver-tin plated copper wires.

Values may change depending upon what type of wire is used.

Positronic Recommended Tools

SND AND SCBC SERIES CRIMP TOOLS	POSITIONERS FOR FC6020D-50-1202.1 FC6026D-50-1202.1 MC6020D-50 MC6026D-50
9507, HAND CRIMP TOOL	9502-5
9550-1, AUTOMATIC FEED, PNEUMATIC STRIP AND CRIMP TOOL	Supplied in reels.

DIMENSIONS ARE IN INCHES (MILLIMETERS).  
ALL DIMENSIONS ARE SUBJECT TO CHANGE.

### ORDERING INFORMATION - CODE NUMBERING SYSTEM

Specify the complete connector by following Steps 1 through 9.  
Insert "0" when a step is not used.

STEP	1	2	3	4	5	6	7	8	9
	SCBC	7W2	M	13	0	0	E	D	

#### STEP 1 - Basic Series

SCBC Series

#### STEP 2 - SCBC Series Connector Variants

##### Shell Size 1

5W1

##### Shell Size 2

7W2, 11W1

##### Shell Size 3

13W3, 17W2, 21W1

##### Shell Size 4

25W3

##### Shell Size 5

36W4, 43W2, 47W1

##### Shell Size 6

46W4

#### STEP 3 - Connector Gender

M -Male

F -Female

#### STEP 4 - Contact Termination Type

0 - Connector ordered without contacts. Order Signal and Shielded contacts separately. See pages 32, 34, and 39 for contact part numbers. Kitted contacts supplied in sealed bags.

1 - Signal Contacts, 20 AWG - 24 AWG (0.5 mm<sup>2</sup> - 0.25 mm<sup>2</sup>).

13 - Signal Contacts, 20 AWG - 24 AWG (0.5 mm<sup>2</sup> - 0.25 mm<sup>2</sup>) with MCC/FCC 4101M Shielded Contacts.

14 - Signal Contacts, 20 AWG - 24 AWG (0.5 mm<sup>2</sup> - 0.25 mm<sup>2</sup>) with MCC/FCC 4102M Shielded Contacts.

#### \* STEP 5 - Mounting Style

0 - Mounting Hole, 0.120(3.05) Ø.

F - Float Mounts, Universal.

S2 - Swaged Spacer, 4-40 Threads, 0.125(3.18) Length.

S5 - Swaged Locknut, 4-40 Threads.

#### STEP 9 - Special Options

Consult Sales Department.

#### STEP 8 - Shell Options

G - Gold over Copper Plate.

D - Gold over Copper Plate and Dimpled.

#### \* STEP 7 - Locking and Polarizing Systems

0 - None.

T - Fixed Female Jackscrews.

T2 - Fixed Female Jackscrews.

T6 - Fixed Male and Female Polarized Jackscrews.

E - Rotating Male Jackscrews.

E2 - Rotating Male Screw Locks.

E6 - Rotating Male and Female Polarized Jackscrews.

#### \* STEP 6 - Hoods

0 - None.

H - Hood, Top Opening, Brass.

M - Hood, Top Opening, Aluminum, see page 52 for complete listing of options.

#### \* NOTE:

For additional information on accessories listed in Steps 5, 6, and 7, see the Accessory Section, pages 48-54.

**AUTOMATIC FEED,  
STRIP AND CRIMP TOOL,  
PNEUMATICALLY ACTUATED**

**Part No. 9550-1**

This fast-cycling automatic feed, strip and crimp tool produces an 8 indent crimp on wire sizes 20 AWG (0.5 mm<sup>2</sup>) through 30 AWG (0.05 mm<sup>2</sup>). SND and SCBC Series contacts must be ordered on reels.

To order, specify part number 9550-1. Foot control valve is supplied as a standard accessory.



**MINIATURE STEP ADJUSTABLE TOOL**

**(M22520/2-01)**

**Part No. 9507**

This miniature 8 step adjustable hand crimping tool produces an 8 indent crimp configuration and will crimp wire sizes 20 AWG (0.5 mm<sup>2</sup>) through 30 AWG (0.05 mm<sup>2</sup>).

To crimp wire size 20 AWG (0.5 mm<sup>2</sup>) through 30 AWG (0.05 mm<sup>2</sup>), order contact positioner 9502-5. Each positioner is equipped with a data plate which gives the correct crimp depth setting for each wire size, and must be used with 9507 tool frame for best results when crimping SND and SCBC Series contacts.



**INSERTION/REMOVAL TOOL**

**(M81969/1-02)**

One end of this tool is used to insert contacts into SND and SCBC Series connectors. The other end is used to extract contacts. This is accomplished by sliding the extraction tip down the wire into the connector until it bottoms against the contact. A slight rotation while pushing will release the contacts, which are then extracted by simultaneously pulling on the wire.

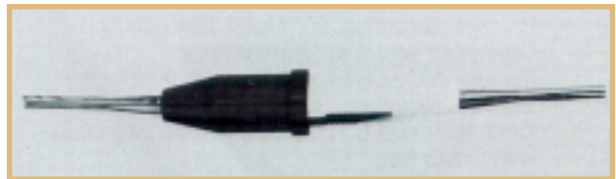

**DIMENSIONS ARE IN INCHES (MILLIMETERS).  
ALL DIMENSIONS ARE SUBJECT TO CHANGE.**

## Space Adapter Series

## SPACE FLIGHT APPLICATION, NORMAL AND HIGH DENSITY SUBMINIATURE-D CONNECTOR SAVERS

Series SAD  
Size 20 Contacts

Series SADD  
Size 22 Contacts

Series SACBM  
Size 20 and  
Size 8 Contacts

Connector Saver



Space Adapter-D Series connectors are space flight application connectors that function as connector savers. The normal density SAD Series is available in five standard connector variants of 9, 15, 25, 37 and 50 contacts. The high density SADD Series is available in six standard connector variants of 15, 26, 44, 62, 78 and 104 contacts. The SACBM Series is available in twenty standard combination contact variants.

Space Adapter-D Series connectors utilize precision

machined contacts for strength and durability. The female contact features a rugged “Closed Entry” design having a brass shroud.

The materials and finishes, as well as the technical characteristics of the Space Adapter-D Series connectors conform to MIL-DTL-24308, GSFC S-311-P-4 and GSFC S-311-P-10.

Visual and mechanical inspection per MIL-DTL-24308 is performed, additional testing is available. Contact Technical Sales.

## SPACE ADAPTER-D SERIES TECHNICAL CHARACTERISTICS

### MATERIALS AND FINISHES:

<b>Insulator:</b>	Glass-filled DAP per ASTM-D-5948 or polyester glass-filled per MIL-M-24519, UL 94V-0, ASTM E-595, NASA-RP-1124.
<b>Contacts:</b>	Precision machined high tensile copper alloy with brass shrouds.
<b>Contact Plating:</b>	0.000050 inch (1.25 microns) gold over copper plate.
<b>Shells:</b>	Brass with 0.000050 inch (1.25 microns) gold over copper plate.

### ELECTRICAL CHARACTERISTICS:

<b>Contact Current Rating:</b>	40 amperes, nominal, Size 8. 7.5 amperes, nominal, Size 20. 5 amperes, nominal, Size 22.
<b>Initial Contact Resistance:</b>	0.008 ohms, maximum.
<b>Proof Voltage:</b>	1,000 V r.m.s.
<b>Insulator Resistance:</b>	5 G ohms.
<b>Clearance and Creepage Distance:</b>	0.039 inch (1.0 mm), minimum.
<b>Working Voltage:</b>	300 V r.m.s.
<b>Residual Magnetism:</b>	20 Gamma, maximum.

### MECHANICAL CHARACTERISTICS:

<b>Fixed Contacts:</b>	<b>Size 8 Contact:</b> 0.142 inch (3.61 mm) diameter. <b>Female Contact:</b> Features large surface area (L.S.A.) closed entry design utilizing BeCu mechanical retention member.
	<b>Size 20 Contact:</b> 0.040 inch (1.02 mm) diameter. <b>Female Contact:</b> Closed entry design with brass shroud.
	<b>Size 22 Contact:</b> 0.030 inch (0.76 mm) diameter. <b>Female Contact:</b> Closed entry design with brass shroud.
<b>Connector Saver:</b>	Male to female.
<b>Contact Retention:</b>	9 lbs. (40 N).
<b>Shells:</b>	Male shells may be dimpled for EMI/ESD ground paths.
<b>Polarization:</b>	Trapezoidally shaped shells.
<b>Mechanical Operations:</b>	1,000 operations, minimum, per IEC 512-5.

### CLIMATIC CHARACTERISTICS:

<b>Temperature Range:</b>	-55°C to +125°C.
---------------------------	------------------



### CONNECTOR VARIANTS FACE VIEW OF MALE

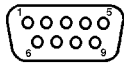

SAD9

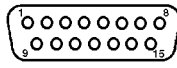

SAD15

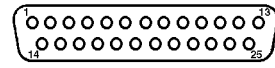

SAD25

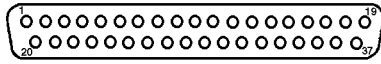

SAD37

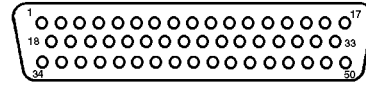

SAD50

### MALE TO FEMALE CONNECTOR SAVER SIZE 20 CONTACTS

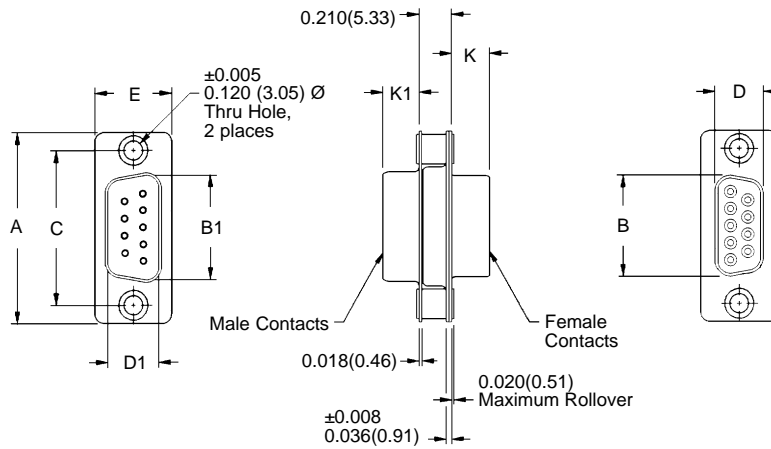

Typical Part Number:  
SAD9M/F

CONNECTOR PART NUMBER	A $\pm 0.015$	B $\pm 0.005$	B1 $\pm 0.005$	C $\pm 0.005$	D $\pm 0.005$	D1 $\pm 0.005$	E $\pm 0.015$	K $\pm 0.005$	K1 $\pm 0.005$
SAD9M/F	1.213 (30.81)	0.643 (16.33)	0.666 (16.92)	0.984 (24.99)	0.311 (7.90)	0.329 (8.36)	0.494 (12.55)	0.243 (6.17)	0.233 (5.92)
SAD15M/F	1.541 (39.14)	0.971 (24.66)	0.994 (25.25)	1.312 (33.32)	0.311 (7.90)	0.329 (8.36)	0.494 (12.55)	0.243 (6.17)	0.233 (5.92)
SAD25M/F	2.088 (53.04)	1.511 (38.38)	1.534 (38.96)	1.852 (47.04)	0.311 (7.90)	0.329 (8.36)	0.494 (12.55)	0.243 (6.17)	0.230 (5.84)
SAD37M/F	2.729 (69.32)	2.159 (54.84)	2.182 (55.42)	2.500 (63.50)	0.311 (7.90)	0.329 (8.36)	0.494 (12.55)	0.243 (6.17)	0.230 (5.84)
SAD50M/F	2.635 (66.93)	2.064 (52.43)	2.079 (52.81)	2.406 (61.11)	0.423 (10.74)	0.441 (11.20)	0.605 (15.37)	0.243 (6.17)	0.230 (5.84)

DIMENSIONS ARE IN INCHES (MILLIMETERS).  
ALL DIMENSIONS ARE SUBJECT TO CHANGE.

### CONNECTOR VARIANTS FACE VIEW OF MALE

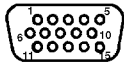

SADD15

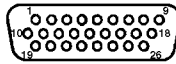

SADD26

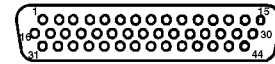

SADD44

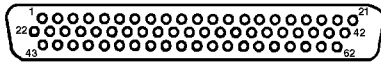

SADD62

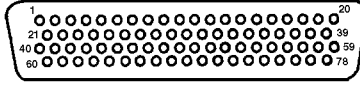

SADD78

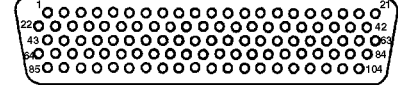

SADD104

### MALE TO FEMALE CONNECTOR SAVER SIZE 22 CONTACTS

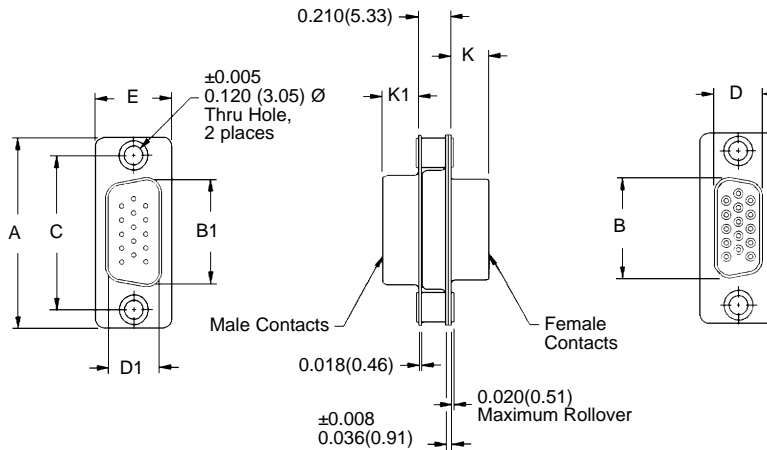

Typical Part Number:  
SADD15M/F

CONNECTOR PART NUMBER	A ±0.015	B ±0.005	B1 ±0.005	C ±0.005	D ±0.005	D1 ±0.005	E ±0.015	K ±0.005	K1 ±0.005
SADD15M/F	1.213 (30.81)	0.643 (16.33)	0.666 (16.92)	0.984 (24.99)	0.311 (7.90)	0.329 (8.36)	0.494 (12.55)	0.243 (6.17)	0.233 (5.92)
SADD26M/F	1.541 (39.14)	0.971 (24.66)	0.994 (25.25)	1.312 (33.32)	0.311 (7.90)	0.329 (8.36)	0.494 (12.55)	0.243 (6.17)	0.233 (5.92)
SADD44M/F	2.088 (53.04)	1.511 (38.38)	1.534 (38.96)	1.852 (47.04)	0.311 (7.90)	0.329 (8.36)	0.494 (12.55)	0.243 (6.17)	0.230 (5.84)
SADD62M/F	2.729 (69.32)	2.159 (54.84)	2.182 (55.42)	2.500 (63.50)	0.311 (7.90)	0.329 (8.36)	0.494 (12.55)	0.243 (6.17)	0.230 (5.84)
SADD78M/F	2.635 (66.93)	2.064 (52.43)	2.079 (52.81)	2.406 (61.11)	0.423 (10.74)	0.441 (11.20)	0.605 (15.37)	0.243 (6.17)	0.230 (5.84)
SADD104M/F	2.729 (69.32)	2.189 (55.60)	2.212 (56.18)	2.500 (63.50)	0.485 (12.32)	0.503 (12.78)	0.668 (16.97)	0.243 (6.17)	0.230 (5.84)

DIMENSIONS ARE IN INCHES (MILLIMETERS).  
ALL DIMENSIONS ARE SUBJECT TO CHANGE.

### CONNECTOR VARIANTS

#### FACE VIEW OF MALE

##### SHELL SIZE 1

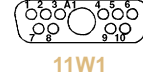
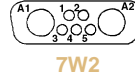
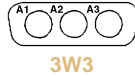

##### SHELL SIZE 3

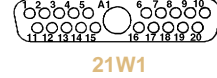
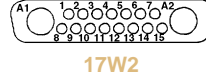
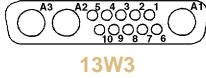
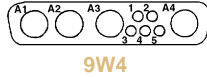

##### SHELL SIZE 4

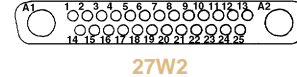
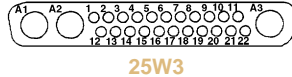
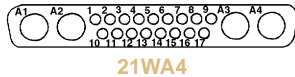
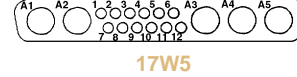
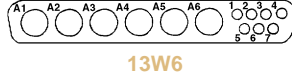
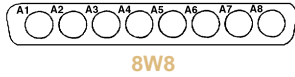

##### SHELL SIZE 5

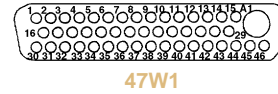
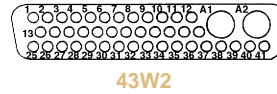
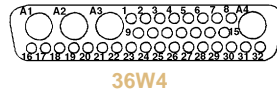
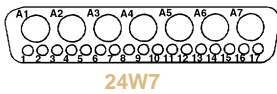

##### SHELL SIZE 6

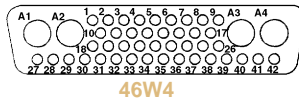

### MALE TO FEMALE CONNECTOR SAVER

#### SIZE 20 AND SIZE 8 CONTACTS

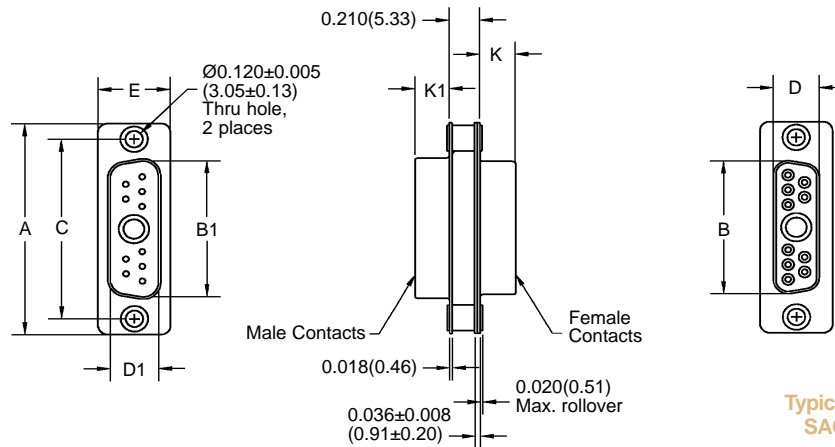

Typical Part Number:  
SACBM11W1M/F

CONNECTOR SIZE	A ±0.015	B ±0.005	B1 ±0.005	C ±0.005	D ±0.005	D1 ±0.005	E ±0.015	K ±0.005	K1 ±0.005
SHELL SIZE 1	1.213 (30.81)	0.643 (16.33)	0.666 (16.92)	0.984 (24.99)	0.311 (7.90)	0.329 (8.36)	0.494 (12.55)	0.243 (6.17)	0.233 (5.92)
SHELL SIZE 2	1.541 (39.14)	0.971 (24.66)	0.994 (25.25)	1.312 (33.32)	0.311 (7.90)	0.329 (8.36)	0.494 (12.55)	0.243 (6.17)	0.233 (5.92)
SHELL SIZE 3	2.088 (53.04)	1.511 (38.38)	1.534 (38.96)	1.852 (47.04)	0.311 (7.90)	0.329 (8.36)	0.494 (12.55)	0.243 (6.17)	0.230 (5.84)
SHELL SIZE 4	2.729 (69.32)	2.159 (54.84)	2.182 (55.42)	2.500 (63.50)	0.311 (7.90)	0.329 (8.36)	0.494 (12.55)	0.243 (6.17)	0.230 (5.84)
SHELL SIZE 5	2.635 (66.93)	2.064 (52.43)	2.079 (52.81)	2.406 (61.11)	0.423 (10.74)	0.441 (11.20)	0.605 (15.37)	0.243 (6.17)	0.230 (5.84)
SHELL SIZE 6	2.729 (69.32)	2.189 (55.60)	2.212 (56.18)	2.500 (63.50)	0.485 (12.32)	0.503 (12.78)	0.668 (16.97)	0.243 (6.17)	0.230 (5.84)

DIMENSIONS ARE IN INCHES (MILLIMETERS).  
ALL DIMENSIONS ARE SUBJECT TO CHANGE.

RIVETED-ON 90° MOUNTING BRACKETS AND PUSH-ON FASTENERS

RIVETED ON RIGHT ANGLE MOUNTING BRACKETS

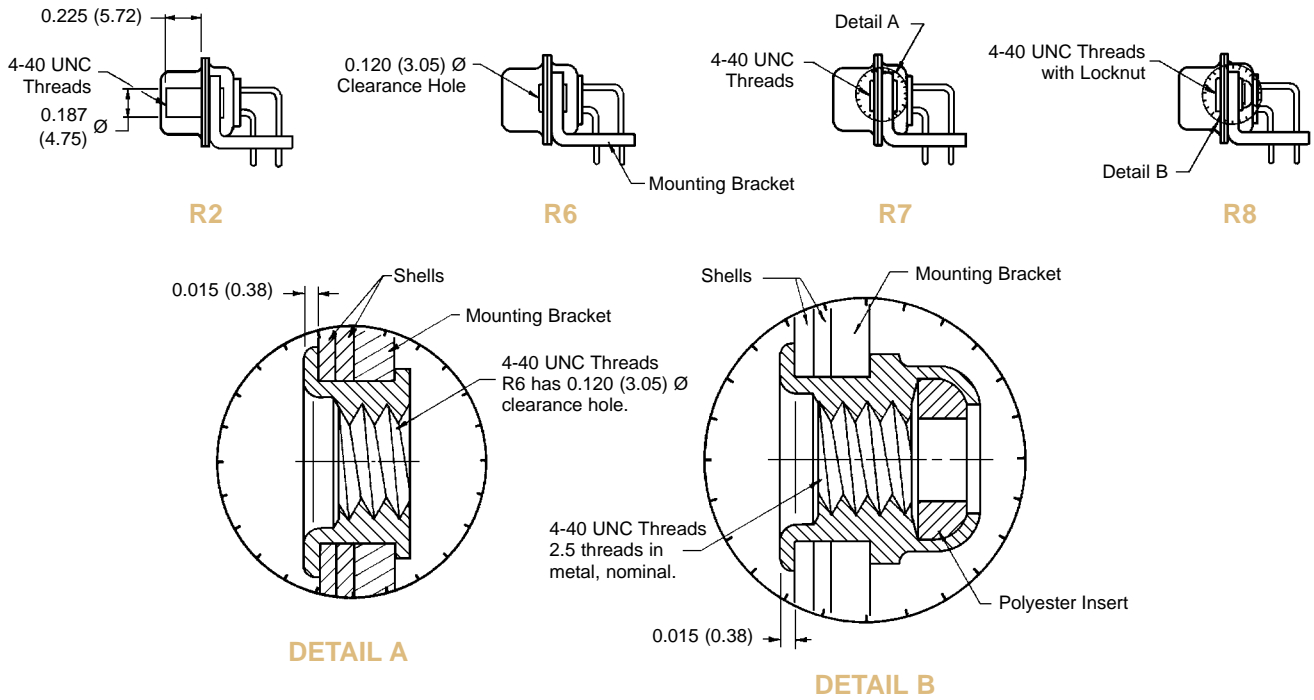

Material: Brass, 0.000050 inch (1.25 μ) gold over copper plate.

PUSH-ON FASTENER FOR RIVETED ON RIGHT ANGLE MOUNTING BRACKETS



SCBM17W2F5R7N0G (shown left)

SDD26F4R7N0G (shown right)

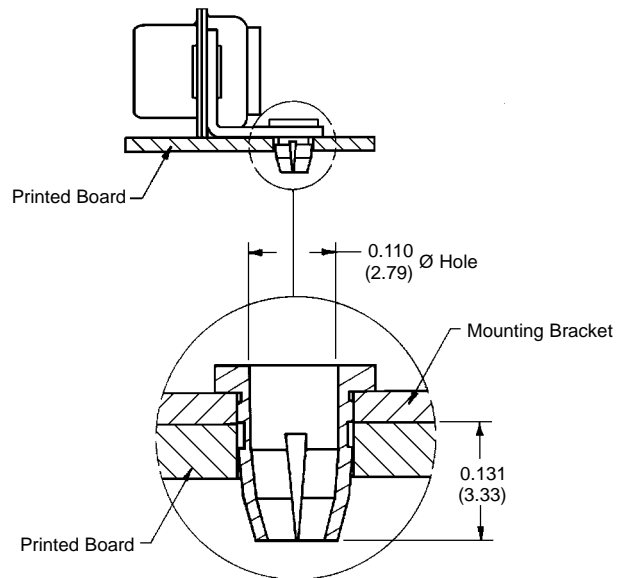

Printed board mounting hole to be 0.123 (3.12) Ø ±0.003 for use with push-on fastener.

Material: Beryllium copper, 0.000050 inch (1.25 μ) gold over copper plate.

SAMPLE #	PRINTED BOARD HOLE Ø	INSERTION FORCE (LBS.)	RETENTION FORCE (LBS.)
1	0.120 (3.05)	7-1/4	5-3/4
2	0.123 (3.12)	5-3/4	5-1/2
3	0.125 (3.18)	2-3/4	2-1/2
4	0.128 (3.25)	1-3/4	2-1/4
5	0.126 (3.20) PLATED	1-3/4	2-1/4

DIMENSIONS ARE IN INCHES (MILLIMETERS). ALL DIMENSIONS ARE SUBJECT TO CHANGE.

SWAGED SPACERS, LOCKNUTS, AND SWAGED SPACERS WITH PUSH-ON FASTENERS

SWAGED SPACER (S)

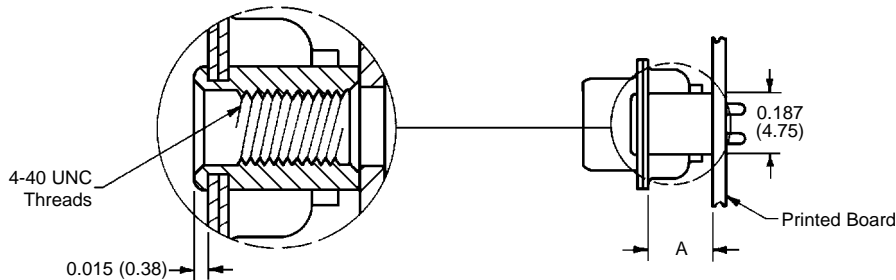

CONNECTOR SERIES	A
SND	0.225 (5.72)
SCBM	0.250 (6.35)
SDD	0.375 (9.53)

Material: Brass, 0.000050 inch (1.25 μ) gold over copper plate.

SWAGED SPACERS (S2)

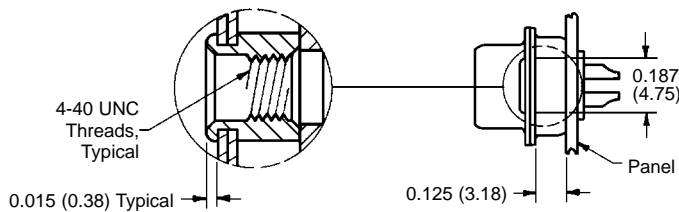

Material: Brass, 0.000050 inch (1.25 μ) gold over copper plate.

SWAGED LOCKNUT (S5)

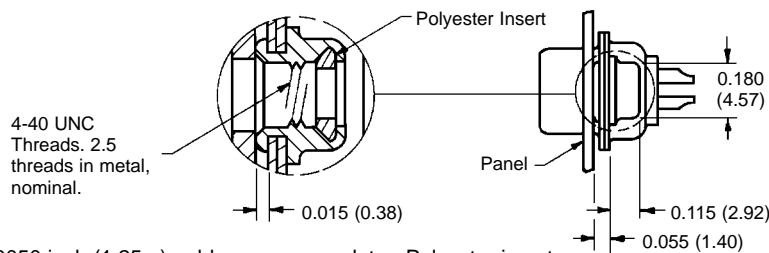

Material: Brass, 0.000050 inch (1.25 μ) gold over copper plate. Polyester insert.

SWAGED SPACER WITH PUSH-ON FASTENER (S6)

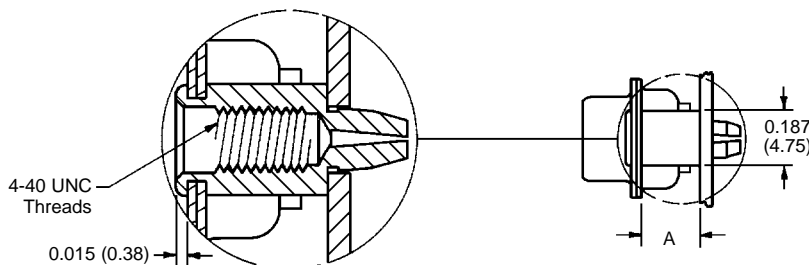

CONNECTOR SERIES	A
SND	0.225 (5.72)
SCBM	0.250 (6.35)
SDD	0.375 (9.53)

Printed board mounting hole to be 0.123 (3.12) Ø ±0.003 for use with push-on fastener.

DIMENSIONS ARE IN INCHES (MILLIMETERS). ALL DIMENSIONS ARE SUBJECT TO CHANGE.

Material: Phosphor bronze, 0.000050 inch (1.25 μ) gold over copper plate.

RIGHT ANGLE METAL MOUNTING BRACKET (B3)

PART NO.	STYLE	A	B	C	D	SIZE	SCBM	SND	SDD
4535-2-0	1	0.324 (8.23)	0.484 (12.29)	0.244 (6.20)	0.358 (9.09)	9 - 37	5, 55, 57	5	
4535-3-0	1	0.380 (9.65)	0.594 (15.09)	0.303 (7.70)	0.417 (10.59)	50	5, 55, 57	5	
4535-5-0	3	0.554 (14.07)	0.739 (18.77)	0.244 (6.20)	0.358 (9.09)	15 - 62			4
4535-6-0	3	0.604 (15.34)	0.800 (20.32)	0.303 (7.70)	0.417 (10.59)	78			4
4535-8-0	2	0.405 (10.29)	0.522 (13.26)	0.246 (6.25)	0.358 (9.09)	9 - 37	7, 75, 77	42	
4535-9-0	2	0.455 (11.56)	0.572 (14.53)	0.303 (7.70)	0.414 (10.52)	50	7, 75, 77	42	

NOTE: Sold only as part of a connector assembly.

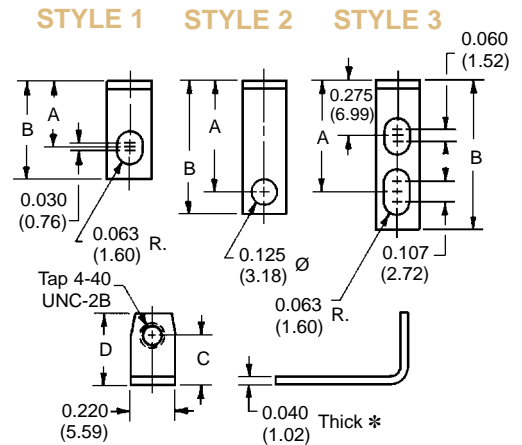

\* 0.062 (1.57) thick for Size 104 SDD Series.

Material: Brass, 0.000050 inch (1.25 μ) gold over copper plate.

RIGHT ANGLE METAL MOUNTING BRACKET USED WITH R2, R6, R7 AND R8 RIVETED-ON BRACKET ASSEMBLIES

PART NO.	A	B	C	D	SIZE	SCBM	SND	SDD
4535-2-1	0.339 (8.61)	0.456 (11.58)	0.246 (6.25)	0.358 (9.09)	9 - 37	5, 55, 57	5	
4535-3-1	0.395 (10.03)	0.512 (13.00)	0.303 (7.70)	0.414 (10.52)	50	5, 55, 57	5	
4535-8-1	0.420 (10.67)	0.537 (13.64)	0.246 (6.25)	0.358 (9.09)	9 - 37	7, 75, 77	42	
4535-9-1	0.470 (11.94)	0.587 (14.91)	0.303 (7.70)	0.414 (10.52)	50	7, 75, 77	42	
4535-34-1	0.528 (13.41)	0.645 (16.38)	0.246 (6.25)	0.358 (9.09)	15 - 62			4
4535-35-1	0.573 (14.55)	0.690 (17.53)	0.303 (7.70)	0.414 (10.52)	78			4
4535-62-1	0.614 (15.60)	0.731 (18.57)	0.334 (8.48)	0.445 (11.30)	104			4

NOTE: Sold only as part of a connector assembly.

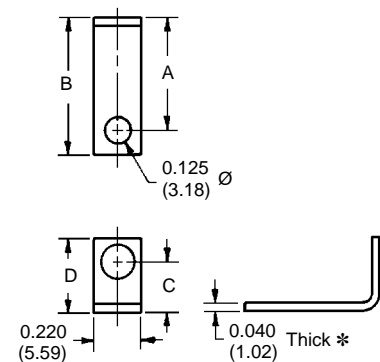

\* 0.062 (1.57) thick for Size 104 SDD Series.

Material: Brass, 0.000050 inch (1.25 μ) gold over copper plate.

DIMENSIONS ARE IN INCHES (MILLIMETERS). ALL DIMENSIONS ARE SUBJECT TO CHANGE.



THREADED POST  
AND METAL HOOD

THREADED POST  
(P)

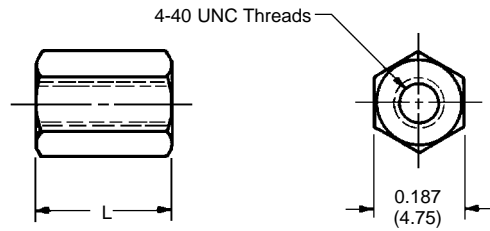

**Material:** Brass, 0.000050 inch (1.25 μ) gold over copper plate.

CONNECTOR SERIES	L
SND	0.225 (5.72)
SCBM	0.250 (6.35)
SDD	0.375 (9.53)

METAL HOOD (H)

PART NO.	A	B	C	D MAX.	E	F	G	H MAX.
SND15000HOG	1.531 (38.88)	0.492 (12.50)	1.312 (33.32)	0.578 (14.68)	0.713 (18.11)	0.312 (7.92)	0.750 (19.05)	1.219 (30.96)
SND25000HOG	2.078 (52.78)	0.492 (12.50)	1.852 (47.04)	0.578 (14.68)	1.000 (25.40)	0.312 (7.92)	1.000 (25.40)	1.532 (38.91)
SND37000HOG	2.718 (69.03)	0.492 (12.50)	2.500 (63.50)	0.578 (14.68)	1.375 (34.93)	0.312 (7.92)	1.000 (25.40)	1.532 (38.91)
SND50000HOG	2.625 (66.68)	0.601 (15.27)	2.406 (61.11)	0.687 (17.45)	1.406 (35.71)	0.406 (10.31)	1.125 (28.58)	1.657 (42.09)

**Material:** Brass, 0.000050 inch (1.25 μ) gold over copper plate.

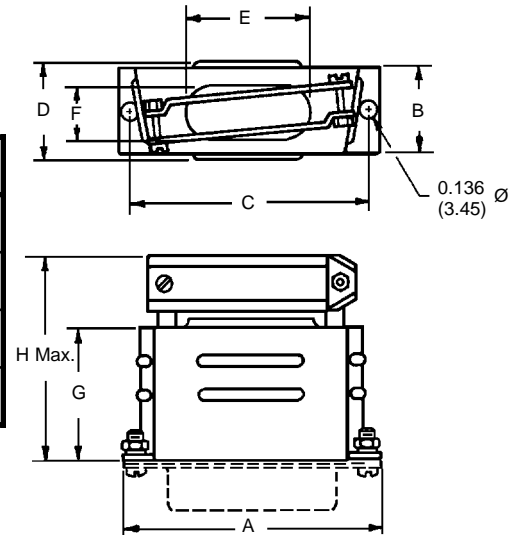

REAR GROMMETS

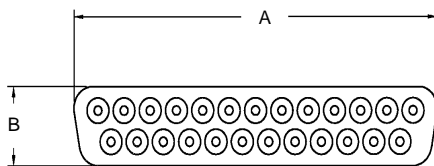

CONNECTOR VARIANTS	A	B
9	0.630 (16.00)	0.284 (7.21)
15	0.960 (24.38)	0.284 (7.21)
25	1.504 (38.21)	0.284 (7.21)
37	2.146 (54.51)	0.284 (7.21)
50	2.054 (52.17)	0.396 (10.06)

**Material:** Silicon rubber.  
Consult factory for ordering information.

Prevent exposure of bare wires during cable flexing.

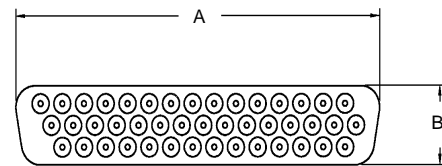
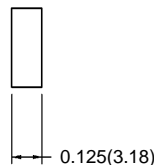

CONNECTOR VARIANTS	A	B
15	0.630 (16.00)	0.284 (7.21)
26	0.960 (24.38)	0.284 (7.21)
44	1.504 (38.21)	0.284 (7.21)
62	2.146 (54.51)	0.284 (7.21)
78	2.054 (52.17)	0.396 (10.06)

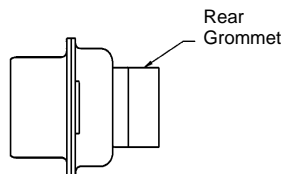

DIMENSIONS ARE IN INCHES (MILLIMETERS).  
ALL DIMENSIONS ARE SUBJECT TO CHANGE.

## EMI/RFI METAL HOOD (M) FOR SPACE APPLICATION SUBMINIATURE-D CONNECTORS

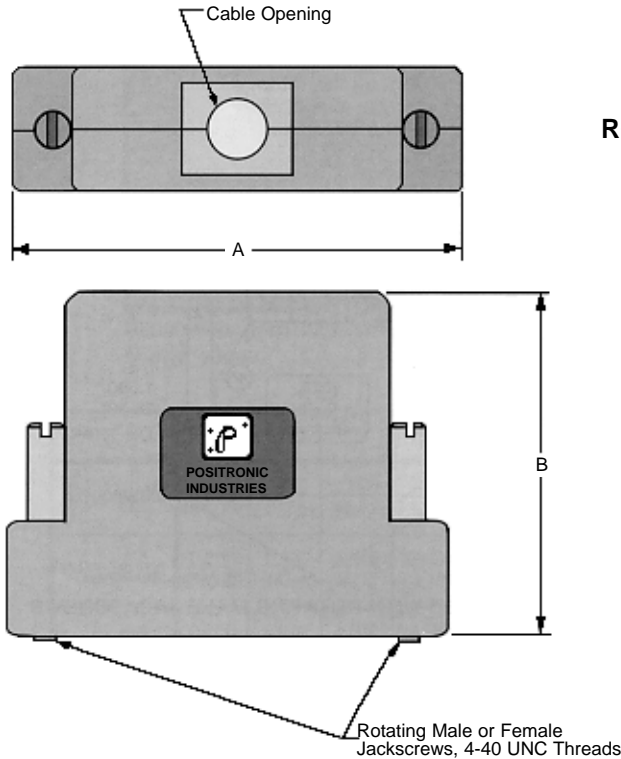

### ALUMINUM HOOD WITH ROTATING MALE OR FEMALE JACKSCREWS

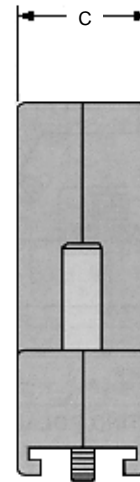

Typical Part Number:  
(FOR HOOD ASSEMBLY)  
D25000M00

Typical Part Number:  
(FOR CABLE ENTRY INSERT)  
4595 - \*\*\* - \*\*\* - \*\*

**NOTE:** Inserts are not supplied with hood and must be ordered separately.

Consult the Factory for part number completion based upon Customer requirements.

**TYPICAL INSERTS**

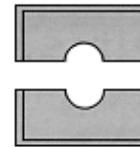

PART NUMBER	A	B	C	CABLE OPENING, MAX.
D9000*00	1.397 (35.48)	1.750 (44.45)	0.630 (16.00)	∅ 0.375 (9.53)
D15000*00	1.725 (43.82)	1.750 (44.45)	0.630 (16.00)	∅ 0.375 (9.53)
D25000*00	2.265 (57.53)	1.750 (44.45)	0.630 (16.00)	∅ 0.450 (11.43)
D37000*00	2.913 (73.99)	1.750 (44.45)	0.630 (16.00)	∅ 0.450 (11.43)
D50000*00	2.819 (71.60)	1.750 (44.45)	0.740 (18.80)	∅ 0.550 (13.97)
D104000*00	2.913 (73.99)	1.750 (44.45)	0.803 (20.40)	∅ 0.625 (15.88)
(*) - DESIGNATES HOOD ACCESSORIES OPTION				

**Material:** Hood - Aluminum per QQ-A-225, yellow chromate conversion per MIL-C-5541 or black anodize per MIL-A-8625 optional.

**Hardware** - Non-magnetic stainless steel per QQ-S-763, passivated per QQ-P-35, or brass per QQ-B-626 with 0.000050 (1.27μ) gold plate over copper per MIL-G-45204 optional.

DIMENSIONS ARE IN INCHES (MILLIMETERS).  
ALL DIMENSIONS ARE SUBJECT TO CHANGE.

HOOD ACCESSORIES PART NUMBERS				
HARDWARE OPTIONS	YELLOW CHROMATE CONVERSION HOOD WITH STAINLESS STEEL HARDWARE	YELLOW CHROMATE CONVERSION HOOD WITH COPPER ALLOY HARDWARE	BLACK ANODIZED HOOD WITH STAINLESS STEEL HARDWARE	BLACK ANODIZED HOOD WITH COPPER ALLOY HARDWARE
MALE ROTATING JACKSCREWS	D*000M00	D*000MG00	D*000MB00	D*000MC00
FEMALE ROTATING JACKSCREWS	D*000M700	D*000M7G00	D*000M7B00	D*000M7C00
ONE (1) MALE ROTATING JACKSCREW AND ONE (1) FEMALE ROTATING JACKSCREW	D*000M600	D*000M6G00	D*000M6B00	D*000M6C00
(*) - DESIGNATES CONNECTOR SIZE				

JACKSCREW SYSTEMS

CODE	A	B
T	0.437 (11.10)	0.250 (6.35)
T2	0.500 (12.70)	0.198 (5.03)

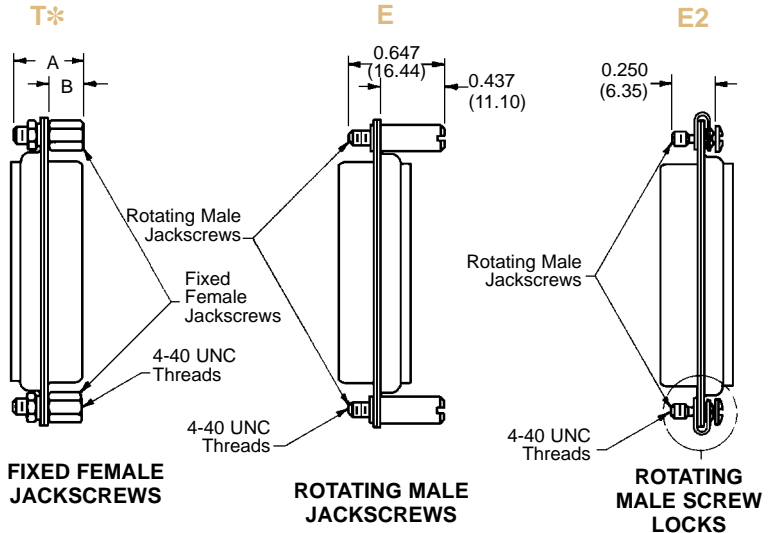

**Jackscrew Material:** Brass, 0.000050 inch (1.25 μ) gold over copper plate.

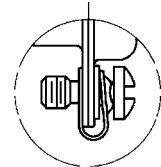

**NOTE:** Stainless steel Jackscrews are available. Consult factory for ordering information.

**Material: Screw** - Brass, 0.000050 inch (1.25 μ) gold over copper plate.

**U-Clip** - Brass, 0.000050 inch (1.25 μ) gold over copper plate.

POLARIZED JACKSCREW SYSTEMS

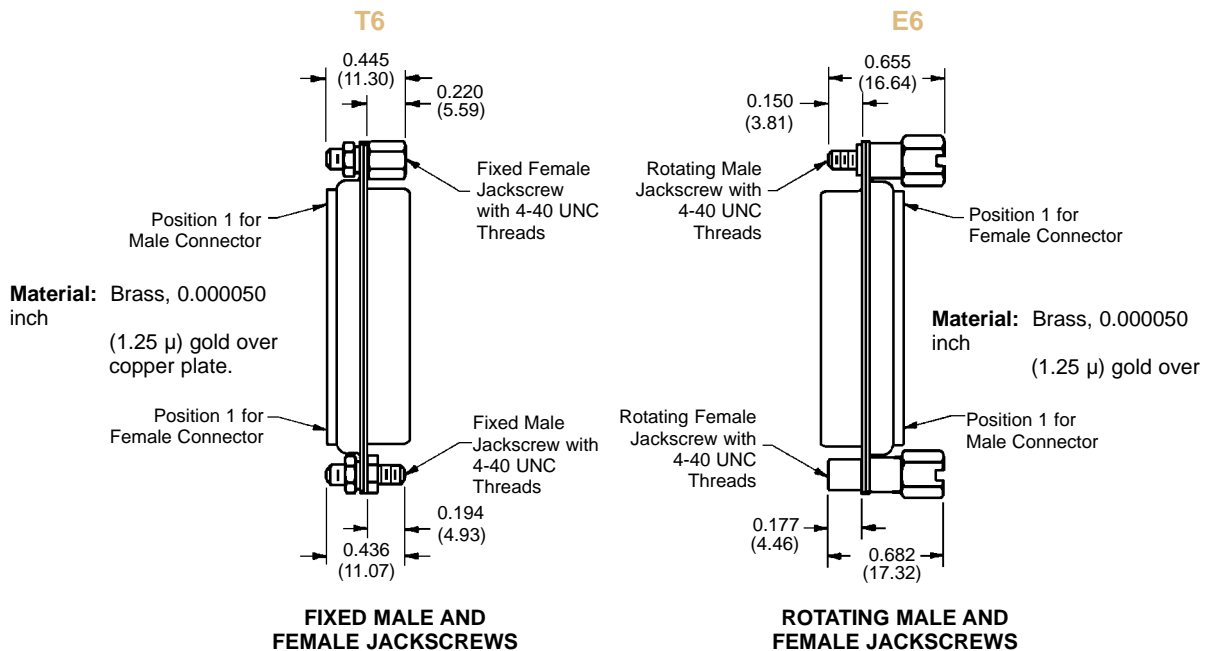

DIMENSIONS ARE IN INCHES (MILLIMETERS). ALL DIMENSIONS ARE SUBJECT TO CHANGE.

IN-LINE CRIMP SPLICE AND PROTECTIVE COVER

IN-LINE CRIMP SPLICE

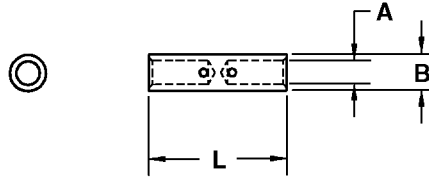

\*: To order crimp splice with insulating sleeve, add "-W" suffix to part number. To order without sleeve, add "-N" suffix.

Consult factory for crimp tool part number.

PART NUMBER	WIRE SIZE AWG/(mm <sup>2</sup> )	L	A	B
PSK43636-*	20-26 AWG (0.5/0.12 mm <sup>2</sup> )	0.500 (12.70)	0.045 (1.14)	0.076 (1.93)
PSK43637-*	16-20 AWG (1.5/0.5 mm <sup>2</sup> )	0.575 (14.61)	0.066 (1.68)	0.101 (2.57)
PSK43638-*	12-18 AWG (4.0-1.0 mm <sup>2</sup> )	0.577 (14.66)	0.097 (2.46)	0.150 (3.81)

Materials:

Splice: Copper alloy, 0.000050 (1.25 μ) gold over copper.

Sleeve: Shrink-fit polyvinylidene fluoride.

EMI/RFI PROTECTIVE COVER

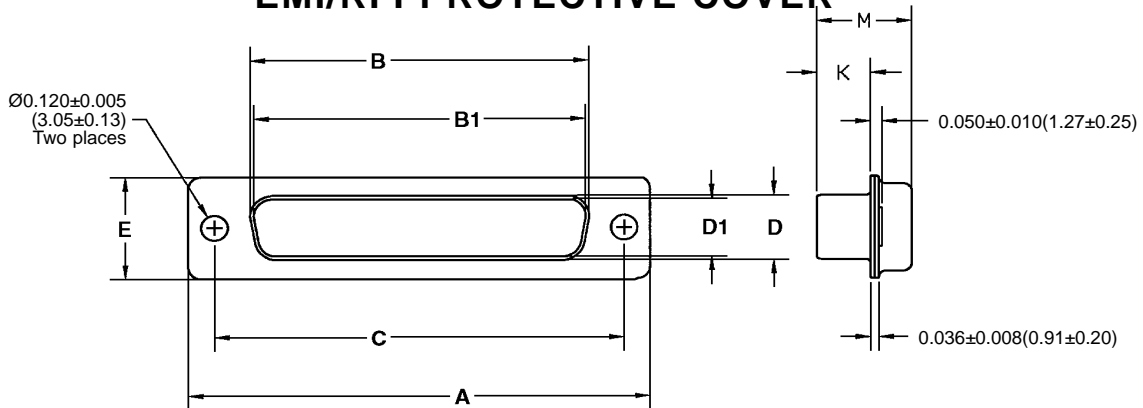

PART NUMBER	CONNECTOR VARIANT SIZES	A ±0.015	B ±0.005	B1 ±0.005	C ±0.005	D ±0.005	D1 ±0.005	E ±0.015	G ±0.010	H ±0.010	K ±0.005	M ±0.010
PSK633-9MG*	9 M/15 M	1.213 (30.81)		0.666 (16.92)	0.984 (24.99)		0.329 (8.36)	0.494 (12.55)	0.759 (19.28)	0.422 (10.72)	0.233 (5.92)	0.422 (10.72)
PSK633-9FG*	9 F/15 F	1.213 (30.81)	0.643 (16.33)		0.984 (24.99)	0.311 (7.90)		0.494 (12.55)	0.759 (19.28)	0.422 (10.72)	0.243 (6.17)	0.429 (10.90)
PSK633-15MG*	15 M/26 M	1.541 (39.14)		0.994 (25.25)	1.312 (33.32)		0.329 (8.36)	0.494 (12.55)	1.083 (27.51)	0.422 (10.72)	0.233 (5.92)	0.422 (10.72)
PSK633-15FG*	15 F/26 F	1.541 (39.14)	0.971 (24.66)		1.312 (33.32)	0.311 (7.90)		0.494 (12.55)	1.083 (27.51)	0.422 (10.72)	0.243 (6.17)	0.429 (10.90)
PSK633-25MG*	25 M/44 M	2.088 (53.04)		1.534 (38.96)	1.852 (47.04)		0.329 (8.36)	0.494 (12.55)	1.625 (41.28)	0.422 (10.72)	0.230 (5.84)	0.426 (10.82)
PSK633-25FG*	25 F/44 F	2.088 (53.04)	1.511 (38.38)		1.852 (47.04)	0.311 (7.90)		0.494 (12.55)	1.625 (41.28)	0.422 (10.72)	0.243 (6.17)	0.429 (10.90)
PSK633-37MG*	37 M/62 M	2.729 (69.32)		2.182 (55.42)	2.500 (63.50)		0.329 (8.36)	0.494 (12.55)	2.272 (57.71)	0.422 (10.72)	0.230 (5.84)	0.426 (10.82)
PSK633-37FG*	37 F/62 F	2.729 (69.32)	2.159 (54.84)		2.500 (63.50)	0.311 (7.90)		0.494 (12.55)	2.272 (57.71)	0.422 (10.72)	0.243 (6.17)	0.429 (10.90)
PSK633-50MG*	50 M/78 M	2.635 (66.93)		2.079 (52.81)	2.406 (61.11)		0.441 (11.20)	0.605 (15.37)	2.178 (55.32)	0.534 (13.56)	0.230 (5.84)	0.426 (10.82)
PSK633-50FG*	50 F/78 F	2.635 (66.93)	2.064 (52.43)		2.406 (61.11)	0.423 (10.74)		0.605 (15.37)	2.178 (55.32)	0.534 (13.56)	0.243 (6.17)	0.429 (10.90)
PSK633-104MG*	- /104 M	2.729 (69.32)		2.212 (56.18)	2.500 (63.50)		0.503 (12.78)	0.668 (16.97)	2.302 (58.47)	0.596 (15.14)	0.230 (5.84)	0.426 (10.82)
PSK633-104FG*	- /104 F	2.729 (69.32)	2.189 (55.60)		2.500 (63.50)	0.485 (12.32)		0.668 (16.97)	2.302 (58.47)	0.596 (15.14)	0.243 (6.17)	0.429 (10.90)

\*: To order protective cover with E2 rotating male screw locks (see page 53), insert "N" into the last digit of part number. Omit this digit if thread locks are not required.

Material: Brass, 0.000050 (1.25 μ) gold over copper.

DIMENSIONS ARE IN INCHES (MILLIMETERS). ALL DIMENSIONS ARE SUBJECT TO CHANGE.

Positronic Industries offers the following listing of connectors and accessories, which are products qualified under GSFC Specifications GSFC-S-311-P-4 and GSFC-S-311-P-10.

GSFC PART NUMBER	POSITRONIC PART NUMBER	GSFC PART NUMBER	POSITRONIC PART NUMBER	GSFC PART NUMBER	POSITRONIC PART NUMBER
311P10-1P-B-12	SND9M2000G-1082.24	311P10-17P-B-12	SCBM17W5M2000G-1082.24	311P10-9P-C-12	SCBM11W1M2000G-1082.24
311P10-1P-B-15	SND9M20200G-1082.24	311P10-17P-B-15	SCBM17W5M20200G-1082.24	311P10-9P-C-15	SCBM11W1M20200G-1082.24
311P10-1S-B-12	SND9F2000G-1082.24	311P10-17S-B-12	SCBM17W5F2000G-1082.24	311P10-9S-C-12	SCBM11W1F2000G-1082.24
311P10-1S-B-15	SND9F20200G-1082.24	311P10-17S-B-15	SCBM17W5F20200G-1082.24	311P10-9S-C-15	SCBM11W1F20200G-1082.24
311P10-2P-B-12	SND15M2000G-1082.24	311P10-18P-B-12	SCBM21WA4M2000G-1082.24	311P10-10P-C-12	SCBM5W5M0000G-1082.24
311P10-2P-B-15	SND15M20200G-1082.24	311P10-18P-B-15	SCBM21WA4M20200G-1082.24	311P10-10P-C-15	SCBM5W5M00200G-1082.24
311P10-2S-B-12	SND15F2000G-1082.24	311P10-18S-B-12	SCBM21WA4F2000G-1082.24	311P10-10S-C-12	SCBM5W5F0000G-1082.24
311P10-2S-B-15	SND15F20200G-1082.24	311P10-18S-B-15	SCBM21WA4F20200G-1082.24	311P10-10S-C-15	SCBM5W5F00200G-1082.24
311P10-3P-B-12	SND25M2000G-1082.24	311P10-20P-B-12	SCBM25W3M2000G-1082.24	311P10-11P-C-12	SCBM9W4M2000G-1082.24
311P10-3P-B-15	SND25M20200G-1082.24	311P10-20P-B-15	SCBM25W3M20200G-1082.24	311P10-11P-C-15	SCBM9W4M20200G-1082.24
311P10-3S-B-12	SND25F2000G-1082.24	311P10-20S-B-12	SCBM25W3F2000G-1082.24	311P10-11S-C-12	SCBM9W4F2000G-1082.24
311P10-3S-B-15	SND25F20200G-1082.24	311P10-20S-B-15	SCBM25W3F20200G-1082.24	311P10-11S-C-15	SCBM9W4F20200G-1082.24
311P10-4P-B-12	SND37M2000G-1082.24	311P10-21P-B-12	SCBM27W2M2000G-1082.24	311P10-12P-C-12	SCBM13W3M2000G-1082.24
311P10-4P-B-15	SND37M20200G-1082.24	311P10-21P-B-15	SCBM27W2M20200G-1082.24	311P10-12P-C-15	SCBM13W3M20200G-1082.24
311P10-4S-B-12	SND37F2000G-1082.24	311P10-21S-B-12	SCBM27W2F2000G-1082.24	311P10-12S-C-12	SCBM13W3F2000G-1082.24
311P10-4S-B-15	SND37F20200G-1082.24	311P10-21S-B-15	SCBM27W2F20200G-1082.24	311P10-12S-C-15	SCBM13W3F20200G-1082.24
311P10-5P-B-12	SND50M2000G-1082.24	311P10-22P-B-12	SCBM24W7M2000G-1082.24	311P10-13P-C-12	SCBM17W2M2000G-1082.24
311P10-5P-B-15	SND50M20200G-1082.24	311P10-22P-B-15	SCBM24W7M20200G-1082.24	311P10-13P-C-15	SCBM17W2M20200G-1082.24
311P10-5S-B-12	SND50F2000G-1082.24	311P10-22S-B-12	SCBM24W7F2000G-1082.24	311P10-13S-C-12	SCBM17W2F2000G-1082.24
311P10-5S-B-15	SND50F20200G-1082.24	311P10-22S-B-15	SCBM24W7F20200G-1082.24	311P10-13S-C-15	SCBM17W2F20200G-1082.24
311P10-6P-B-12	SCBM5W1M2000G-1082.24	311P10-23P-B-12	SCBM36W4M2000G-1082.24	311P10-14P-C-12	SCBM21W1M2000G-1082.24
311P10-6P-B-15	SCBM5W1M20200G-1082.24	311P10-23P-B-15	SCBM36W4M20200G-1082.24	311P10-14P-C-15	SCBM21W1M20200G-1082.24
311P10-6S-B-12	SCBM5W1F2000G-1082.24	311P10-23S-B-12	SCBM36W4F2000G-1082.24	311P10-14S-C-12	SCBM21W1F2000G-1082.24
311P10-6S-B-15	SCBM5W1F20200G-1082.24	311P10-23S-B-15	SCBM36W4F20200G-1082.24	311P10-14S-C-15	SCBM21W1F20200G-1082.24
311P10-7P-B-12	SCBM3W3M0000G-1082.24	311P10-24P-B-12	SCBM43W2M2000G-1082.24	311P10-15P-C-12	SCBM8W8M0000G-1082.24
311P10-7P-B-15	SCBM3W3M00200G-1082.24	311P10-24P-B-15	SCBM43W2M20200G-1082.24	311P10-15P-C-15	SCBM8W8M00200G-1082.24
311P10-7S-B-12	SCBM3W3F0000G-1082.24	311P10-24S-B-12	SCBM43W2F2000G-1082.24	311P10-15S-C-12	SCBM8W8F0000G-1082.24
311P10-7S-B-15	SCBM3W3F00200G-1082.24	311P10-24S-B-15	SCBM43W2F20200G-1082.24	311P10-15S-C-15	SCBM8W8F00200G-1082.24
311P10-8P-B-12	SCBM7W2M2000G-1082.24	311P10-25P-B-12	SCBM47W1M2000G-1082.24	311P10-16P-C-12	SCBM13W6M2000G-1082.24
311P10-8P-B-15	SCBM7W2M20200G-1082.24	311P10-25P-B-15	SCBM47W1M20200G-1082.24	311P10-16P-C-15	SCBM13W6M20200G-1082.24
311P10-8S-B-12	SCBM7W2F2000G-1082.24	311P10-25S-B-12	SCBM47W1F2000G-1082.24	311P10-16S-C-12	SCBM13W6F2000G-1082.24
311P10-8S-B-15	SCBM7W2F20200G-1082.24	311P10-25S-B-15	SCBM47W1F20200G-1082.24	311P10-16S-C-15	SCBM13W6F20200G-1082.24
311P10-9P-B-12	SCBM11W1M2000G-1082.24	311P10-1P-C-12	SND9M2000G-1082.24	311P10-17P-C-12	SCBM17W5M2000G-1082.24
311P10-9P-B-15	SCBM11W1M20200G-1082.24	311P10-1P-C-15	SND9M20200G-1082.24	311P10-17P-C-15	SCBM17W5M20200G-1082.24
311P10-9S-B-12	SCBM11W1F2000G-1082.24	311P10-1S-C-12	SND9F2000G-1082.24	311P10-17S-C-12	SCBM17W5F2000G-1082.24
311P10-9S-B-15	SCBM11W1F20200G-1082.24	311P10-1S-C-15	SND9F20200G-1082.24	311P10-17S-C-15	SCBM17W5F20200G-1082.24
311P10-10P-B-12	SCBM5W5M0000G-1082.24	311P10-2P-C-12	SND15M2000G-1082.24	311P10-18P-C-12	SCBM21WA4M2000G-1082.24
311P10-10P-B-15	SCBM5W5M00200G-1082.24	311P10-2P-C-15	SND15M20200G-1082.24	311P10-18P-C-15	SCBM21WA4M20200G-1082.24
311P10-10S-B-12	SCBM5W5F0000G-1082.24	311P10-2S-C-12	SND15F2000G-1082.24	311P10-18S-C-12	SCBM21WA4F2000G-1082.24
311P10-10S-B-15	SCBM5W5F00200G-1082.24	311P10-2S-C-15	SND15F20200G-1082.24	311P10-18S-C-15	SCBM21WA4F20200G-1082.24
311P10-11P-B-12	SCBM9W4M2000G-1082.24	311P10-3P-C-12	SND25M2000G-1082.24	311P10-20P-C-12	SCBM25W3M2000G-1082.24
311P10-11P-B-15	SCBM9W4M20200G-1082.24	311P10-3P-C-15	SND25M20200G-1082.24	311P10-20P-C-15	SCBM25W3M20200G-1082.24
311P10-11S-B-12	SCBM9W4F2000G-1082.24	311P10-3S-C-12	SND25F2000G-1082.24	311P10-20S-C-12	SCBM25W3F2000G-1082.24
311P10-11S-B-15	SCBM9W4F20200G-1082.24	311P10-3S-C-15	SND25F20200G-1082.24	311P10-20S-C-15	SCBM25W3F20200G-1082.24
311P10-12P-B-12	SCBM13W3M2000G-1082.24	311P10-4P-C-12	SND37M2000G-1082.24	311P10-21P-C-12	SCBM27W2M2000G-1082.24
311P10-12P-B-15	SCBM13W3M20200G-1082.24	311P10-4P-C-15	SND37M20200G-1082.24	311P10-21P-C-15	SCBM27W2M20200G-1082.24
311P10-12S-B-12	SCBM13W3F2000G-1082.24	311P10-4S-C-12	SND37F2000G-1082.24	311P10-21S-C-12	SCBM27W2F2000G-1082.24
311P10-12S-B-15	SCBM13W3F20200G-1082.24	311P10-4S-C-15	SND37F20200G-1082.24	311P10-21S-C-15	SCBM27W2F20200G-1082.24
311P10-13P-B-12	SCBM17W2M2000G-1082.24	311P10-5P-C-12	SND50M2000G-1082.24	311P10-22P-C-12	SCBM24W7M2000G-1082.24
311P10-13P-B-15	SCBM17W2M20200G-1082.24	311P10-5P-C-15	SND50M20200G-1082.24	311P10-22P-C-15	SCBM24W7M20200G-1082.24
311P10-13S-B-12	SCBM17W2F2000G-1082.24	311P10-5S-C-12	SND50F2000G-1082.24	311P10-22S-C-12	SCBM24W7F2000G-1082.24
311P10-13S-B-15	SCBM17W2F20200G-1082.24	311P10-5S-C-15	SND50F20200G-1082.24	311P10-22S-C-15	SCBM24W7F20200G-1082.24
311P10-14P-B-12	SCBM21W1M2000G-1082.24	311P10-6P-C-12	SCBM5W1M2000G-1082.24	311P10-23P-C-12	SCBM36W4M2000G-1082.24
311P10-14P-B-15	SCBM21W1M20200G-1082.24	311P10-6P-C-15	SCBM5W1M20200G-1082.24	311P10-23P-C-15	SCBM36W4M20200G-1082.24
311P10-14S-B-12	SCBM21W1F2000G-1082.24	311P10-6S-C-12	SCBM5W1F2000G-1082.24	311P10-23S-C-12	SCBM36W4F2000G-1082.24
311P10-14S-B-15	SCBM21W1F20200G-1082.24	311P10-6S-C-15	SCBM5W1F20200G-1082.24	311P10-23S-C-15	SCBM36W4F20200G-1082.24
311P10-15P-B-12	SCBM8W8M0000G-1082.24	311P10-7P-C-12	SCBM3W3M0000G-1082.24	311P10-24P-C-12	SCBM43W2M2000G-1082.24
311P10-15P-B-15	SCBM8W8M00200G-1082.24	311P10-7P-C-15	SCBM3W3M00200G-1082.24	311P10-24P-C-15	SCBM43W2M20200G-1082.24
311P10-15S-B-12	SCBM8W8F0000G-1082.24	311P10-7S-C-12	SCBM3W3F0000G-1082.24	311P10-24S-C-12	SCBM43W2F2000G-1082.24
311P10-15S-B-15	SCBM8W8F00200G-1082.24	311P10-7S-C-15	SCBM3W3F00200G-1082.24	311P10-24S-C-15	SCBM43W2F20200G-1082.24
311P10-16P-B-12	SCBM13W6M2000G-1082.24	311P10-8P-C-12	SCBM7W2M2000G-1082.24	311P10-25P-C-12	SCBM47W1M2000G-1082.24
311P10-16P-B-15	SCBM13W6M20200G-1082.24	311P10-8P-C-15	SCBM7W2M20200G-1082.24	311P10-25P-C-15	SCBM47W1M20200G-1082.24
311P10-16S-B-12	SCBM13W6F2000G-1082.24	311P10-8S-C-12	SCBM7W2F2000G-1082.24	311P10-25S-C-12	SCBM47W1F2000G-1082.24
311P10-16S-B-15	SCBM13W6F20200G-1082.24	311P10-8S-C-15	SCBM7W2F20200G-1082.24	311P10-25S-C-15	SCBM47W1F20200G-1082.24

Positronic Industries offers the following listing of connectors and accessories, which are products qualified under GSFC Specifications GSFC-S-311-P-4 and GSFC-S-311-P-10.

**NOTE: Items denoted by \* are undergoing qualification.  
Consult factory for availability of items denoted by \*\*.**

GSFC PART NUMBER	POSITRONIC PART NUMBER	GSFC PART NUMBER	POSITRONIC PART NUMBER	GSFC PART NUMBER	POSITRONIC PART NUMBER
311P405-6P-B-12	SCBC5W1M0000G-1082.24	**311P405-21P-B-12	SCBC27W2M0000G-1082.24	311P409-4P-B-12	SND37M0000G-1082.24
311P405-6P-B-15	SCBC5W1M00200G-1082.24	**311P405-21P-B-15	SCBC27W2M00200G-1082.24	311P409-4P-B-15	SND37M00200G-1082.24
311P405-6S-B-12	SCBC5W1F0000G-1082.24	**311P405-21S-B-12	SCBC27W2F0000G-1082.24	311P409-4S-B-12	SND37F0000G-1082.24
311P405-6S-B-15	SCBC5W1F00200G-1082.24	**311P405-21S-B-15	SCBC27W2F00200G-1082.24	311P409-4S-B-15	SND37F00200G-1082.24
311P405-7P-B-12	SCBM3W3M0000G-1082.24	**311P405-22P-B-12	SCBC24W7M0000G-1082.24	311P409-5P-B-12	SND50M0000G-1082.24
311P405-7P-B-15	SCBM3W3M00200G-1082.24	**311P405-22P-B-15	SCBC24W7M00200G-1082.24	311P409-5P-B-15	SND50M00200G-1082.24
311P405-7S-B-12	SCBM3W3F0000G-1082.24	311P405-22S-B-12	SCBC24W7F0000G-1082.24	311P409-5S-B-12	SND50F0000G-1082.24
311P405-7S-B-15	SCBM3W3F00200G-1082.24	311P405-22S-B-15	SCBC24W7F00200G-1082.24	311P409-5S-B-15	SND50F00200G-1082.24
311P405-8P-B-12	SCBC7W2M0000G-1082.24	311P405-23P-B-12	SCBC36W4M0000G-1082.24	G08P1	MC8022D-50-1202.4
311P405-8P-B-15	SCBC7W2M00200G-1082.24	311P405-23P-B-15	SCBC36W4M00200G-1082.24	G08S1	FC8022D-50-1202.4
311P405-8S-B-12	SCBC7W2F0000G-1082.24	311P405-23S-B-12	SCBC36W4F0000G-1082.24	G10P1	MC6020D-50-1202.4
311P405-8S-B-15	SCBC7W2F00200G-1082.24	311P405-23S-B-15	SCBC36W4F00200G-1082.24	G10S1	FC6020D-50-1202.4
311P405-9P-B-12	SCBC11W1M0000G-1082.24	311P405-24P-B-12	SCBC43W2M0000G-1082.24	*GCP1	MC4101M
311P405-9P-B-15	SCBC11W1M00200G-1082.24	311P405-24P-B-15	SCBC43W2M00200G-1082.24	*GCP2	MC4102M
311P405-9S-B-12	SCBC11W1F0000G-1082.24	311P405-24S-B-12	SCBC43W2F0000G-1082.24	*GCP3	MC4103M
311P405-9S-B-15	SCBC11W1F00200G-1082.24	311P405-24S-B-15	SCBC43W2F00200G-1082.24	*GCP4	MC4104M
311P405-10P-B-12	SCBM5W5M0000G-1082.24	311P405-25P-B-12	SCBC47W1M0000G-1082.24	*GCRP1	MC4201M
311P405-10P-B-15	SCBM5W5M00200G-1082.24	311P405-25P-B-15	SCBC47W1M00200G-1082.24	*GCRP2	MC4202M
311P405-10S-B-12	SCBM5W5F0000G-1082.24	311P405-25S-B-12	SCBC47W1F0000G-1082.24	*GCRP3	MC4203M
311P405-10S-B-15	SCBM5W5F00200G-1082.24	311P405-25S-B-15	SCBC47W1F00200G-1082.24	*GCRP4	MC4204M
**311P405-11P-B-12	SCBC9W4M0000G-1082.24	311P407-1P-B-12	SDD15M0000G-1082.24	*GCS1	FC4101M
**311P405-11P-B-15	SCBC9W4M00200G-1082.24	311P407-1P-B-15	SDD15M00200G-1082.24	*GCS2	FC4102M
**311P405-11S-B-12	SCBC9W4F0000G-1082.24	311P407-1S-B-12	SDD15F0000G-1082.24	*GCS3	FC4103M
**311P405-11S-B-15	SCBC9W4F00200G-1082.24	311P407-1S-B-15	SDD15F00200G-1082.24	*GCS4	FC4104M
311P405-12P-B-12	SCBC13W3M0000G-1082.24	311P407-2P-B-12	SDD26M0000G-1082.24	*GCRS1	FC4201M
311P405-12P-B-15	SCBC13W3M00200G-1082.24	311P407-2P-B-15	SDD26M00200G-1082.24	*GCRS2	FC4202M
311P405-12S-B-12	SCBC13W3F0000G-1082.24	311P407-2S-B-12	SDD26F0000G-1082.24	*GCRS3	FC4203M
311P405-12S-B-15	SCBC13W3F00200G-1082.24	311P407-2S-B-15	SDD26F00200G-1082.24	*GCRS4	FC4204M
311P405-13P-B-12	SCBC17W2M0000G-1082.24	311P407-3P-B-12	SDD44M0000G-1082.24	*GHP6	MS4820M
311P405-13P-B-15	SCBC17W2M00200G-1082.24	311P407-3P-B-15	SDD44M00200G-1082.24	*GHS6	FS4820M
311P405-13S-B-12	SCBC17W2F0000G-1082.24	311P407-3S-B-12	SDD44F0000G-1082.24	*GHRP6	MS4920M
311P405-13S-B-15	SCBC17W2F00200G-1082.24	311P407-3S-B-15	SDD44F00200G-1082.24	*GHR6	FS4920M
311P405-14P-B-12	SCBC21W1M0000G-1082.24	311P407-4P-B-12	SDD62M0000G-1082.24		
311P405-14P-B-15	SCBC21W1M00200G-1082.24	311P407-4P-B-15	SDD62M00200G-1082.24		
311P405-14S-B-12	SCBC21W1F0000G-1082.24	311P407-4S-B-12	SDD62F0000G-1082.24		
311P405-14S-B-15	SCBC21W1F00200G-1082.24	311P407-4S-B-15	SDD62F00200G-1082.24		
311P405-15P-B-12	SCBM8W8M0000G-1082.24	311P407-5P-B-12	SDD78M0000G-1082.24		
311P405-15P-B-15	SCBM8W8M00200G-1082.24	311P407-5P-B-15	SDD78M00200G-1082.24		
311P405-15S-B-12	SCBM8W8F0000G-1082.24	311P407-5S-B-12	SDD78F0000G-1082.24		
311P405-15S-B-15	SCBM8W8F00200G-1082.24	311P407-5S-B-15	SDD78F00200G-1082.24		
**311P405-16P-B-12	SCBC13W6M0000G-1082.24	311P407-6P-B-12	SDD104M0000G-1082.24		
**311P405-16P-B-15	SCBC13W6M00200G-1082.24	311P407-6P-B-15	SDD104M00200G-1082.24		
**311P405-16S-B-12	SCBC13W6F0000G-1082.24	311P407-6S-B-12	SDD104F0000G-1082.24		
**311P405-16S-B-15	SCBC13W6F00200G-1082.24	311P407-6S-B-15	SDD104F00200G-1082.24		
**311P405-17P-B-12	SCBC17W5M0000G-1082.24	311P409-1P-B-12	SND9M0000G-1082.24		
**311P405-17P-B-15	SCBC17W5M00200G-1082.24	311P409-1P-B-15	SND9M00200G-1082.24		
**311P405-17S-B-12	SCBC17W5F0000G-1082.24	311P409-1S-B-12	SND9F0000G-1082.24		
**311P405-17S-B-15	SCBC17W5F00200G-1082.24	311P409-1S-B-15	SND9F00200G-1082.24		
311P405-18P-B-12	SCBC21WA4M0000G-1082.24	311P409-2P-B-12	SND15M0000G-1082.24		
311P405-18P-B-15	SCBC21WA4M00200G-1082.24	311P409-2P-B-15	SND15M00200G-1082.24		
311P405-18S-B-12	SCBC21WA4F0000G-1082.24	311P409-2S-B-12	SND15F0000G-1082.24		
311P405-18S-B-15	SCBC21WA4F00200G-1082.24	311P409-2S-B-15	SND15F00200G-1082.24		
311P405-20P-B-12	SCBC25W3M0000G-1082.24	311P409-3P-B-12	SND25M0000G-1082.24		
311P405-20P-B-15	SCBC25W3M00200G-1082.24	311P409-3P-B-15	SND25M00200G-1082.24		
311P405-20S-B-12	SCBC25W3F0000G-1082.24	311P409-3S-B-12	SND25F0000G-1082.24		
311P405-20S-B-15	SCBC25W3F00200G-1082.24	311P409-3S-B-15	SND25F00200G-1082.24		



Positronic HDM Series Connectors are Q.P.L. approved to MIL-DTL-24308 per test report number 24308-618-79/24308-1210-85.

Positronic RD Series Hoods are Q.P.L. approved to MIL-C-85049 per test report number 85049-870-84.

Positronic DD Series Connectors are Q.P.L. approved to MIL-DTL-24308 per test report number 24308-1209-85/24308-1210-85/24308-117-89.

Positronic RD Series Connectors are Q.P.L. approved to MIL-DTL-24308 per test report number 24308-211-79/24308-1210-85.

Positronic RD Series Contacts are Q.P.L. approved to MIL-C-39029 per test report number 39029-694-79.

MILITARY PART NUMBER	POSITRONIC PART NUMBER	MILITARY PART NUMBER	POSITRONIC PART NUMBER	MILITARY PART NUMBER	POSITRONIC PART NUMBER
M24308/5-34	HDM9F20000-403.3	M24308/6-564	RD25F11F000-403.6	M24308/8-361	RD50M00000-403.3
M24308/5-35	HDM15F20000-403.3	M24308/6-565	RD37F11F000-403.6	M24308/8-362	DD15M00000-403.3
M24308/5-36	HDM25F20000-403.3	M24308/6-566	RD50F11F000-403.6	M24308/8-363	DD26M00000-403.3
M24308/5-37	HDM37F20000-403.3	M24308/6-567	DD15F11F000-403.6	M24308/8-364	DD44M00000-403.3
M24308/5-38	HDM50F20000-403.3	M24308/6-568	DD26F11F000-403.6	M24308/8-365	DD62M00000-403.3
M24308/5-56	HDM9F2F000-403.4	M24308/6-569	DD44F11F000-403.6	M24308/8-366	DD78M00000-403.3
M24308/5-57	HDM15F2F000-403.4	M24308/6-570	DD62F11F000-403.6	M24308/8-367	DD104M00000-403.3
M24308/5-58	HDM25F2F000-403.4	M24308/6-571	DD78F11F000-403.6	M24308/8-401	RD9M11F000-403.4
M24308/5-59	HDM37F2F000-403.4	M24308/6-572	DD104F11F000-403.6	M24308/8-402	RD15M11F000-403.4
M24308/5-60	HDM50F2F000-403.4	M24308/6-573	RD9F0F000-403.4	M24308/8-403	RD25M11F000-403.4
M24308/6-502	RD9F110000-50-403.3	M24308/6-574	RD15F0F000-403.4	M24308/8-404	RD37M11F000-403.4
M24308/6-503	RD15F110000-50-403.3	M24308/6-575	RD25F0F000-403.4	M24308/8-405	RD50M11F000-403.4
M24308/6-504	RD25F110000-50-403.3	M24308/6-576	RD37F0F000-403.4	M24308/8-406	DD15M11F000-403.4
M24308/6-505	RD37F110000-50-403.3	M24308/6-577	RD50F0F000-403.4	M24308/8-407	DD26M11F000-403.4
M24308/6-506	RD50F110000-50-403.3	M24308/6-578	RD78F0F000-403.4	M24308/8-408	DD44M11F000-403.4
M24308/6-507	RD9F110000-50-403.5	M24308/6-579	DD26F0F000-403.4	M24308/8-409	DD62M11F000-403.4
M24308/6-508	RD15F110000-50-403.5	M24308/6-580	DD44F0F000-403.4	M24308/8-410	DD78M11F000-403.4
M24308/6-509	RD25F110000-50-403.5	M24308/6-581	DD62F0F000-403.4	M24308/8-411	DD104M11F000-403.4
M24308/6-510	RD37F110000-50-403.5	M24308/6-582	DD78F0F000-403.4	M24308/8-412	RD9M11F000-403.6
M24308/6-511	RD50F110000-50-403.5	M24308/6-583	DD104F0F000-403.4	M24308/8-413	RD15M11F000-403.6
M24308/6-512	DD15F110000-50-403.3	M24308/7-23	HDM9M20000-403.3	M24308/8-414	RD25M11F000-403.6
M24308/6-513	DD26F110000-50-403.3	M24308/7-24	HDM15M20000-403.3	M24308/8-415	RD37M11F000-403.6
M24308/6-514	DD44F110000-50-403.3	M24308/7-25	HDM25M20000-403.3	M24308/8-416	RD50M11F000-403.6
M24308/6-515	DD62F110000-50-403.3	M24308/7-26	HDM37M20000-403.3	M24308/8-417	DD15M11F000-403.6
M24308/6-516	DD78F110000-50-403.3	M24308/7-27	HDM50M20000-403.3	M24308/8-418	DD26M11F000-403.6
M24308/6-517	DD104F110000-50-403.3	M24308/7-34	HDM9M2F000-403.4	M24308/8-419	DD44M11F000-403.6
M24308/6-518	DD15F110000-50-403.5	M24308/7-35	HDM15M2F000-403.4	M24308/8-420	DD62M11F000-403.6
M24308/6-519	DD26F110000-50-403.5	M24308/7-36	HDM25M2F000-403.4	M24308/8-421	DD78M11F000-403.6
M24308/6-520	DD44F110000-50-403.5	M24308/7-37	HDM37M2F000-403.4	M24308/8-422	DD104M11F000-403.6
M24308/6-521	DD62F110000-50-403.5	M24308/7-38	HDM50M2F000-403.4	M24308/8-423	RD9M0F000-403.4
M24308/6-522	DD78F110000-50-403.5	M24308/8-335	RD9M110000-403.3	M24308/8-424	RD15M0F000-403.4
M24308/6-523	DD104F110000-50-403.5	M24308/8-336	RD15M110000-403.3	M24308/8-425	RD25M0F000-403.4
M24308/6-540	RD9F00000-403.3	M24308/8-337	RD25M110000-403.3	M24308/8-426	RD37M0F000-403.4
M24308/6-541	RD15F00000-403.3	M24308/8-338	RD37M110000-403.3	M24308/8-427	RD50M0F000-403.4
M24308/6-542	RD25F00000-403.3	M24308/8-339	RD50M110000-403.3	M24308/8-428	DD15M0F000-403.4
M24308/6-543	RD37F00000-403.3	M24308/8-340	RD9M110000-403.5	M24308/8-429	DD26M0F000-403.4
M24308/6-544	RD50F00000-403.3	M24308/8-341	RD15M110000-403.5	M24308/8-430	DD44M0F000-403.4
M24308/6-545	DD15F00000-403.3	M24308/8-342	RD25M110000-403.5	M24308/8-431	DD62M0F000-403.4
M24308/6-546	DD26F00000-403.3	M24308/8-343	RD37M110000-403.5	M24308/8-432	DD78M0F000-403.4
M24308/6-547	DD44F00000-403.3	M24308/8-344	RD50M110000-403.5	M24308/8-433	DD104M0F000-403.4
M24308/6-548	DD62F00000-403.3	M24308/8-345	DD15M110000-403.3	M39029/57-354	FC8522D-50
M24308/6-549	DD78F00000-403.3	M24308/8-346	DD26M110000-403.3	M39029/58-360	MC8522D-50
M24308/6-550	DD104F00000-403.3	M24308/8-347	DD44M110000-403.3	M39029/63-368	FC5020D-50
M24308/6-551	RD9F11F000-50-403.4	M24308/8-348	DD62M110000-403.3	M39029/64-369	MC5020D-50
M24308/6-552	RD15F11F000-50-403.4	M24308/8-349	DD78M110000-403.3		
M24308/6-553	RD25F11F000-50-403.4	M24308/8-350	DD104M110000-403.3		
M24308/6-554	RD37F11F000-50-403.4	M24308/8-351	DD15M110000-403.5		
M24308/6-555	RD50F11F000-50-403.4	M24308/8-352	DD26M110000-403.5		
M24308/6-556	DD15F11F000-50-403.4	M24308/8-353	DD44M110000-403.5		
M24308/6-557	DD26F11F000-50-403.4	M24308/8-354	DD62M110000-403.5		
M24308/6-558	DD44F11F000-50-403.4	M24308/8-355	DD78M110000-403.5		
M24308/6-559	DD62F11F000-50-403.4	M24308/8-356	DD104M110000-403.5		
M24308/6-560	DD78F11F000-50-403.4	M24308/8-357	RD9M00000-403.3		
M24308/6-561	DD104F11F000-50-403.4	M24308/8-358	RD15M00000-403.3		
M24308/6-562	RD9F11F000-403.6	M24308/8-359	RD25M00000-403.3		
M24308/6-563	RD15F11F000-403.6	M24308/8-360	RD37M00000-403.3		

# Positronic Hermetic Connector Assemblies

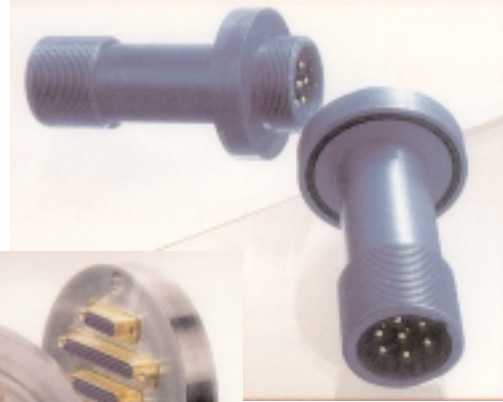
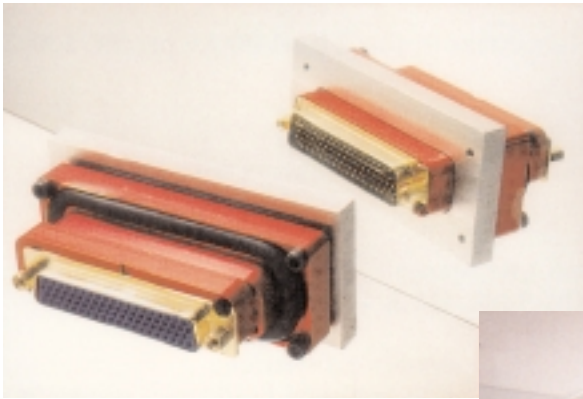

- **Leakage Rate:  $<10^{-9}$  mbar.l/s**
- **Shock and vibration resistant**
- **Application Specific Design**

---

Positronic Industries can supply hermetic connector assemblies for use in vacuum applications. All Positronic hermetic connectors are designed to act as feedthroughs through the bulkhead/chamber wall. Typically both sides of the connector have mating faces, but certain contact terminations are also available per customer requirement. Typical configurations include:

- Standard Density D-Subminiature (Contact size 20)
- High Density D-Subminiature (Contact size 22)
- Mixed Density D-Subminiature (Contact sizes 8 and 20 in a single package)
- Circular (Variety of contact sizes and configurations)

In addition to simply providing the hermetic connector itself, Positronic can provide a fully-assembled flange/plate according to customer specification (see above). For more information on Positronic hermetic capabilities, please call (800) 641-4054 and request to speak to someone about the Positronic hermetic product line.

## **NORTH AMERICAN HEADQUARTERS**

### **UNITED STATES, Springfield, Missouri**

Factory Sales and Engineering Offices (800)641-4054

### **PUERTO RICO, Ponce Factory**

Factory Sales and Engineering Offices (787)841-0920

### **MEXICO**

Factory Sales and Engineering Offices (800)872-7674

### **CANADA**

Factory Sales and Engineering Offices (800)327-8272

## **PACIFIC BASIN HEADQUARTERS**

### **SINGAPORE, Asian Factory**

Factory Sales and Engineering Offices 65-6842-1419

Malaysia Sales Office 65-6842-1419

Taiwan Sales Office 8862-2937-8775

China (Shanghai) Sales Office 8621-6308-3640

Japan Sales Office 8135-661-3047

\*Additional Technical Agents in Australia, New Zealand, India  
South Korea, Thailand, Philippines, Hong Kong and Indonesia.

## **EUROPEAN HEADQUARTERS**

### **FRANCE, Auch Factory**

Factory Sales and Engineering Offices 33 5 62 63 44 91

### **EUROPE, Direct Sales Offices**

Northern France Sales Office 33 1 45 88 13 88

Southern France Sales Office 33 4 67 72 80 28

Italy Sales Office 39 2 54 116 106

Germany Sales Office 49 2351 63 47 39

### **EUROPE, Technical Agents**

Technical Agents in Austria, Benelux, Denmark, Finland, Greece,  
Ireland, Scotland, Slovenia, Spain, Sweden, Switzerland and the  
United Kingdom

### **MIDEAST, Technical Agents**

Technical Agents in Israel and Turkey

### **POSITRONIC INDUSTRIES, INC.**

423 N Campbell Ave • PO Box 8247 • Springfield, MO 65801  
Tel (417) 866-2322 • Fax (417) 866-4115 • Toll Free (800) 641-4054  
info@connectpositronic.com

### **POSITRONIC INDUSTRIES, S.A.S.**

Zone Industrielle d'Engachies • 46 Route d'Engachies • F-32020  
Auch Cedex 9 • France  
Telephone 05 62 63 44 91 • Telecopieur 05 62 63 51 17  
contact@connectpositronic.com

### **POSITRONIC ASIA PTE LTD.**

3014A Ubi Road 1 #06-07 • Singapore 408703  
Telephone (65) 6842-1419 • Fax (65) 6842-1421  
singapore@connectpositronic.com