



**1N4099UR thru 1N4135UR
(or MLL4099 thru MLL4135)
and
1N4614UR thru 1N4627UR
(or MLL4614 thru MLL4627)**

**GLASS SURFACE MOUNT 0.5 WATT
ZENERS**

DESCRIPTION

The 1N4099UR thru 1N4135UR and 1N4614UR thru 1N4627UR series of 0.5 watt glass surface mount DO-213AA Zener voltage regulators provides a selection from 1.8 to 100 volts in standard 5% tolerances as well as tighter tolerances identified by different suffix letters on the part number. These are also available with an internal-metallurgical-bond option by adding a "-1" suffix (see separate data sheet) including JAN, JANTX, and JANTXV military qualifications. Microsemi also offers numerous other Zener products to meet higher and lower power applications.

APPEARANCE

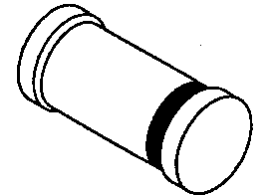

DO-213AA

IMPORTANT: For the most current data, consult MICROSEMI's website: <http://www.microsemi.com>

FEATURES

- Surface mount equivalent to JEDEC registered 1N4099 thru 1N4135 and 1N4614 thru 1N4627 series
- Internal metallurgical bond option available by adding a "-1" suffix that also includes JAN, JANTX, and JANTXV qualifications per MIL-PRF-19500/435 (see separate data sheet for same part numbers with "-1" suffix)
- DO-7 or DO-35 glass body axial-leaded Zener equivalents also available per JEDEC registration (see separate data sheet for part numbers 1N4099 thru 1N4135 and 1N4614 thru 1N4627 series)

APPLICATIONS / BENEFITS

- Regulates voltage over a broad operating current and temperature range
- Extensive selection from 1.8 to 100 V
- Standard voltage tolerances are plus/minus 5% with no suffix
- Tight tolerances available in plus or minus 2% or 1% with C or D suffix respectively
- Hermetically sealed surface mount package
- Nonsensitive to ESD per MIL-STD-750 Method 1020
- Minimal capacitance (see Figure 3)
- Inherently radiation hard as described in Microsemi MicroNote 050

MAXIMUM RATINGS

- Operating and Storage temperature: -65°C to +175°C
- Thermal Resistance: 150°C/W junction to end cap and 300°C/W junction to ambient when mounted on FR4 PC board (1 oz Cu) with recommended footprint (see last page)
- Steady-State Power: 0.5 watts at end cap temperature $T_{EC} \leq 100^\circ\text{C}$ or ambient temperature $T_A \leq 25^\circ\text{C}$ when mounted on FR4 PC board as described for thermal resistance above (see Figure 2 for derating)
- Forward voltage @200 mA: 1.1 volts
- Solder Temperatures: 260°C for 10 s (max)

MECHANICAL AND PACKAGING

- CASE: Hermetically sealed glass DO-213AA (SOD80 or MLL34) MELF style package
- TERMINALS: End caps tin-lead plated solderable per MIL-STD-750, method 2026
- POLARITY: Cathode indicated by band where diode is to be operated with the banded end positive with respect to the opposite end for Zener regulation
- MARKING: cathode band only
- TAPE & REEL option: Standard per EIA-481-1-A with 12 mm tape, 2000 per 7 inch reel or 5000 per 13 inch reel (add "TR" suffix to part number)
- WEIGHT: 0.04 grams
- See package dimensions on last page



1N4099UR thru 1N4135UR
(or MLL4099 thru MLL4135)
and
1N4614UR thru 1N4627UR
(or MLL4614 thru MLL4627)

*** ELECTRICAL CHARACTERISTICS @ 25°C**

INDUSTRY PART NUMBER (NOTE 1)	MICROSEMI PART NUMBER (NOTE 1)	NOMINAL ZENER VOLTAGE $V_Z @ I_{ZT}$ (NOTE 2)	ZENER TEST CURRENT I_{ZT}	MAXIMUM ZENER IMPEDANCE Z_{ZT} (Note 3)	MAXIMUM REVERSE CURRENT $I_R @ V_R$		MAXIMUM NOISE DENSITY $N_D @ I_{ZT}$	MAXIMUM ZENER CURRENT I_{ZM}	TYPICAL TEMP. COEFF. OF ZENER VOLTAGE α_{VZ}
		VOLTS	μA	OHMS	μA	Volts	$\mu V/\sqrt{Hz}$	mA	%/°C
1N4614UR	MLL4614	1.8	250	1200	3.5	1.0	1	120	-0.075
1N4615UR	MLL4615	2.0	250	1250	2.5	1.0	1	110	-0.075
1N4616UR	MLL4616	2.2	250	1300	2.0	1.0	1	100	-0.075
1N4617UR	MLL4617	2.4	250	1400	1.0	1.0	1	95	-0.075
1N4618UR	MLL4618	2.7	250	1500	0.5	1.0	1	90	-0.075
1N4619UR	MLL4619	3.0	250	1600	0.4	1.0	1	87	-0.075
1N4620UR	MLL4620	3.3	250	1650	3.5	1.5	1	85	-0.075
1N4621UR	MLL4621	3.6	250	1700	3.5	2.0	1	83	-0.065
1N4622UR	MLL4622	3.9	250	1650	2.5	2.0	1	80	-0.060
1N4623UR	MLL4623	4.3	250	1600	2.0	2.0	1	77	-0.050
1N4624UR	MLL4624	4.7	250	1550	5.0	3.0	1	75	-0.040,+0.020
1N4625UR	MLL4625	5.1	250	1500	5.0	3.0	2	70	-0.045,+0.030
1N4626UR	MLL4626	5.6	250	1400	5.0	4.0	4	65	-0.020,+0.040
1N4627UR	MLL4627	6.2	250	1200	5.0	5.0	5	61	-0.010,+0.050
1N4099UR	MLL4099	6.8	250	200	1.0	5.17	40	56	0.040
1N4100UR	MLL4100	7.5	250	200	1.0	5.70	40	51	0.045
1N4101UR	MLL4101	8.2	250	200	0.5	6.24	40	46	0.048
1N4102UR	MLL4102	8.7	250	200	0.5	6.61	40	44	0.049
1N4103UR	MLL4103	9.1	250	200	0.5	6.92	40	42	0.050
1N4104UR	MLL4104	10	250	200	0.5	7.60	40	38	0.055
1N4105UR	MLL4105	11	250	200	.05	8.44	40	35	0.060
1N4106UR	MLL4106	12	250	200	.05	9.12	40	32	0.065
1N4107UR	MLL4107	13	250	200	.05	9.87	40	29	0.065
1N4108UR	MLL4108	14	250	200	.05	10.65	40	27	0.070
1N4109UR	MLL4109	15	250	100	.05	11.40	40	25	0.070
1N4110UR	MLL4110	16	250	100	.05	12.15	40	24	0.070
1N4111UR	MLL4111	17	250	100	.05	12.92	40	22	0.075
1N4112UR	MLL4112	18	250	100	.05	13.67	40	21	0.075
1N4113UR	MLL4113	19	250	150	.05	14.44	40	20	0.075
1N4114UR	MLL4114	20	250	150	.01	15.20	40	19	0.075
1N4115UR	MLL4115	22	250	150	.01	16.72	40	17	0.080
1N4116UR	MLL4116	24	250	150	.01	18.25	40	16	0.080
1N4117UR	MLL4117	25	250	150	.01	1900	40	15	0.080
1N4118UR	MLL4118	27	250	150	.01	20.45	40	14	0.085
1N4119UR	MLL4119	28	250	200	.01	21.28	40	14	0.085
1N4120UR	MLL4120	30	250	200	.01	22.80	40	13	0.085
1N4121UR	MLL4121	33	250	200	.01	25.08	40	12	0.085
1N4122UR	MLL4122	36	250	200	.01	27.38	40	11	0.090
1N4123UR	MLL4123	39	250	200	.01	29.65	40	9.8	0.090
1N4124UR	MLL4124	43	250	250	.01	32.65	40	8.9	0.090
1N4125UR	MLL4125	47	250	250	.01	35.75	40	8.1	0.090
1N4126UR	MLL4126	51	250	300	.01	38.76	40	7.5	0.090
1N4127UR	MLL4127	56	250	300	.01	42.60	40	6.7	0.090
1N4128UR	MLL4128	60	250	400	.01	45.60	40	6.4	0.090
1N4129UR	MLL4129	62	250	500	.01	47.10	40	6.1	0.090
1N4130UR	MLL4130	68	250	700	.01	51.68	40	5.6	0.095
1N4131UR	MLL4131	75	250	700	.01	57.00	40	5.1	0.095
1N4132UR	MLL4132	82	250	800	.01	62.32	40	4.6	0.095
1N4133UR	MLL4133	87	250	1000	.01	66.12	40	4.4	0.095
1N4134UR	MLL4134	91	250	1200	.01	69.16	40	4.2	0.095
1N4135UR	MLL4135	100	250	1500	.01	76.00	40	3.8	0.095

NOTE 1: These may be ordered as either 1N4614UR-1N4627UR, 1N4099UR-1N4135UR or as the MLL4614-MLL4627, MLL4099-MLL4135.

NOTE 2: The JEDEC type numbers shown above have a standard tolerance of +/-5% for nominal Zener voltage and are also available in 2% and 1% tolerance with suffix C and D respectively. V_Z is measured with the diode in thermal equilibrium (still air) at 25°C for end-cap terminations.

NOTE 3: The zener impedance is derived by superimposing on I_{ZT} , a 60 Hz rms ac current equal to 10% of I_{ZT} (25 μA). See MicroNote 202 for zener impedance variation with different operating currents.

GRAPHS and CIRCUIT

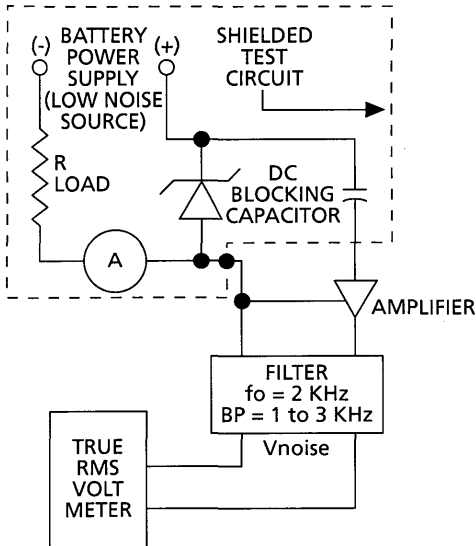
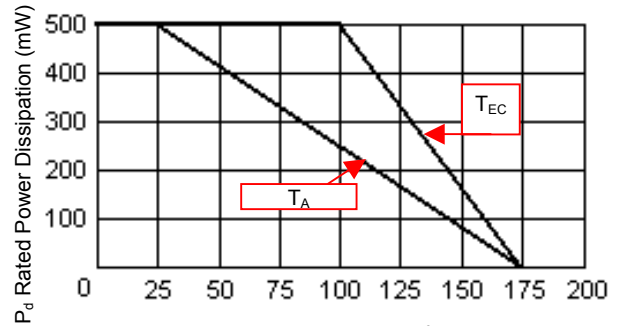

FIGURE 1 Noise Density Measurement Circuit

Noise density, (N_D) is specified in microvolt-rms per square-root-hertz. Actual measurement is performed using a 1 KHz to 3 KHz frequency bandpass filter at a constant Zener test current (I_{ZT}) AT 25°C ambient temperature. N_D is calculated from the formula.



T_{EC} , End Cap Temperature (°C) or T_A
Ambient temperature on FR4 PC board
FIGURE 2 Power Derating Curve

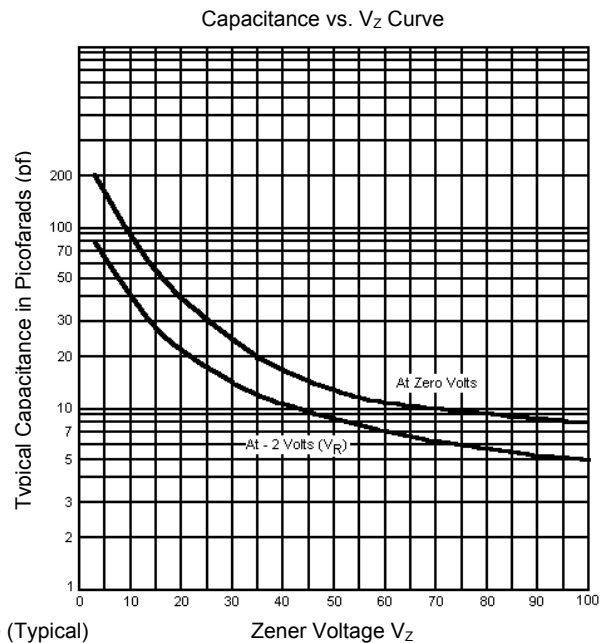
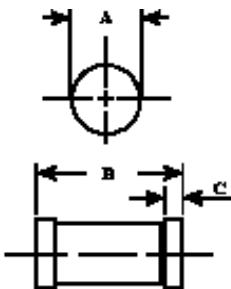
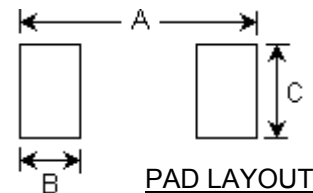

FIGURE 3 Capacitance vs. Zener Voltage (Typical)

PACKAGE DIMENSIONS



DIM	INCHES		MILLIMETERS	
	MIN	MAX	MIN	MAX
A	0.063	0.067	1.60	1.70
B	0.130	0.146	3.30	3.70
C	0.016	0.022	0.41	0.55



	INCHES	mm
A	.200	5.08
B	.055	1.40
C	.080	2.03