

CFPT-9050 Series

ISSUE 6 ; 23 DECEMBER 2004

Recommended for New Designs

Delivery Options

- Please contact our sales office for current leadtimes

Description

- A highly versatile series of surface mountable 14.7 x 9.2 x 6.2mm temperature compensated voltage controlled crystal oscillators (TCVCXOs) for applications where small size and high performance are pre-requisites. This oscillator uses C-MAC's latest custom ASIC "Pluto", a single chip oscillator and analogue compensation circuit, capable of sub 0.3 ppm performance. Its wide frequency range, operating temperature range, drive capability, coupled with its high stability and linear frequency pulling make it the ideal reference oscillator. Its ability to function down to a supply voltage of 2.4V and low power consumption makes it particularly suitable for mobile applications

Standard Frequencies

- 9.6, 10.0, 12.8, 19.44, 20.0, 38.88, 49.152, 51.84MHz

Waveform

- Square HCMOS 15pF load
- Square AC MOS 50pF max. load
- Sinewave 10kΩ // 10pF, AC-coupled
- Clipped sinewave 10kΩ // 10pF, AC-coupled

Supply Voltage

- Operating range 2.4 to 6.0V, see table

Current Consumption

- HCMOS Typically = $1 + \text{Frequency(MHz)} * \text{Supply(V)} * \{\text{Load(pF)} + 15\} * 10^{-3}$ mA
e.g. 20MHz, 5V, 15pF = 4mA
- AC MOS Typically = $1 + \text{Frequency(MHz)} * \text{Supply(V)} * \{\text{Load(pF)} + 23\} * 10^{-3}$ mA
- Sinewave, 6 to 12 mA depending on frequency
- Clipped Sinewave, Typically = $1 + \text{Frequency(MHz)} * 1.2 * \{\text{Load(pF)} + 30\} * 10^{-3}$ mA

Package Outline

- 14.7 x 9.2 x 6.2mm SMD

Ageing

- ±1ppm maximum in first year
- ±3ppm maximum for 10 years
- ±1ppm maximum after reflow

Frequency Stability

- Temperature: see table
- Typical Supply Voltage Variation $\pm 10\% \leq \pm 0.2$ ppm*
- Typical Load Coefficient 15pF $\pm 5\text{pF} \leq \pm 0.2$ ppm*

* Depending on frequency and output type

Frequency Adjustment

- Three options with external Voltage Control applied to pad 1:

A - Ageing adjustment: $\geq \pm 5$ ppm (Standard Option)

B - No frequency adjustment. Initial calibration @ 25°C $\leq \pm 0.5$ ppm

C - High Pulling ± 10 ppm to ± 50 ppm can be available depending on frequency and stability options. Please consult our sales office

- Linearity $\leq 1\%$
- Slope Positive
- Input resistance $> 100\text{k}\Omega$
- Modulation bandwidth $> 2\text{kHz}$
- Standard control voltage ranges:
Without reference voltage - $V_s = 5.0\text{V}$ 2.5V $\pm 2\text{V}$
Without reference voltage - $V_s = 3.3\text{V}$ 1.65V $\pm 1\text{V}$
With reference voltage - $V_c = 0\text{V}$ to V_{ref}

Reference Voltage, Vref (HCMOS/ACMOS only)

- Optional reference voltage output on pad 5, suitable for potentiometer supply or DAC reference.
 1. No output (standard option)
 2. 2.2V, for Min. $V_s > 2.4\text{V}$
 3. 2.7V, for Min. $V_s > 3.0\text{V}$
 4. 4.2V, for Min. $V_s > 4.5\text{V}$
 Maximum load current (mA) = $V_{\text{ref}} / 10$

For manual frequency adjustment (HCMOS/ACMOS output only) connect an external 50kΩ potentiometer between pad 5 (Reference Voltage) and pad 3 (GND) with wiper connected to pad 1 (Voltage Control). Please specify reference voltage as a part of the ordering code

Note: Please contact our sales office if a reference voltage is required in combination with sine or clipped sinewave output

Tri-state

- Pad 2 open circuit or $> 0.6\text{Vs}$ output enabled
- $< 0.2\text{Vs}$ Tri-state
- When Tri-stated, the output stage is disabled for all output options, but the oscillator and compensation circuit are still active (current consumption $< 1\text{mA}$)



Storage Temperature Range

- -55 to 125°C

Environmental Specification

- Vibration: IEC 60068-2-6 Test Fc Procedure B4, 10-60Hz 1.5mm displacement, 60 -2000Hz at 98.1m/s², 30 minutes in each of three mutually perpendicular axes at 1 octave per minute
- Shock: IEC 60068-2-27 Test Ea, 980m/s² acceleration for 6ms duration, 3 shocks in each direction along three mutually perpendicular axes
- Soldering: SMD product suitable for Convection Reflow soldering. Peak temperature 230°C. Maximum time above 200°C, 90 secs.
- Solderability: MIL-STD-202, Method 208, Category 3
- Marking: Laser Marked

Marking Includes

- C-MAC
- Part Number (E and four digits)
- Frequency (MHz)
- Pad 1 / Static sensitivity identifier (Triangle)
- Date code and manufacturing location code (YYWWL)

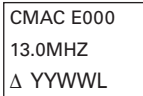

Minimum Order Information Required

- Frequency + Model Number + Frequency Stability Vs Operating Temperature Range Code + Reference Voltage Code + Frequency Adjustment Code + Lead-free version code

OR

- Discrete part number for repeat orders (Discrete part numbers suitable for Lead-free soldering have a 'LF'suffix, e.g. E3131LF

Please supply full information for non-standard options, if required

Test Circuit

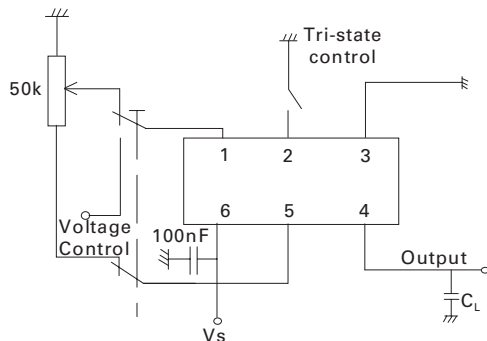

Outline in mm

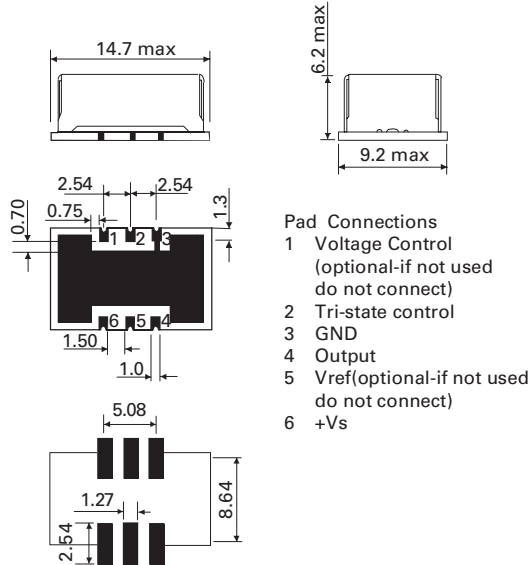

Output Waveform - HCMOS

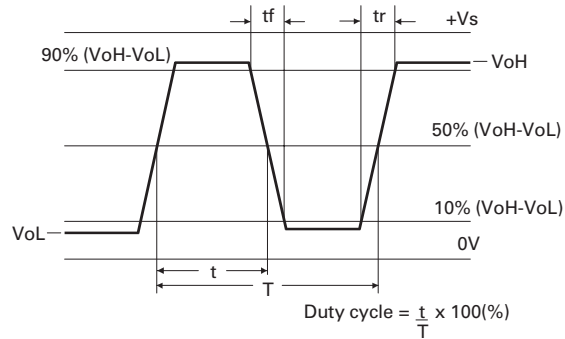

SURFACE MOUNT TCXOs



Phase Noise (typical figures)

Frequency	Frequency offset from carrier: 10Hz	Frequency offset from carrier: 100Hz	Frequency offset from carrier: 1kHz	Frequency offset from carrier: 10kHz	Frequency offset from carrier: 100kHz
13.0MHz	-95 dBc/Hz	-120 dBc/Hz	-135 dBc/Hz	-140 dBc/Hz	-145 dBc/Hz

Electrical Specification - limiting values when measured in test circuit

Frequency Range	Supply Voltage	Output Waveform	Output levels	Rise Time(tr)	Fall Time (tf)	Duty Cycle	Model Number
1.0MHz to 50.0MHz	3.3V±10%	Square HCMOS 15pF	VoH ≥ 90% Vs VoL ≤ 10% Vs	8ns	8ns	45/55%	CFPT-9058
1.0MHz to 50.0MHz	5.0V±10%	Square HCMOS 15pF	VoH ≥ 90% Vs VoL ≤ 10% Vs	7ns	7ns	45/55%	CFPT-9051
8.0MHz to 50.0MHz	3.3V±10%	Sine 10kΩ//10pF	≤20.0MHz: ≥1.0 Vpp >20.0MHz: ≥0.5Vpp	—		—	CFPT-9059
8.0MHz to 50.0MHz	5.0V±10%	Sine 10kΩ//10pF	≤20.0MHz: ≥1.0 Vpp >20.0MHz: ≥0.5Vpp	—		—	CFPT-9053
1.0MHz to 80.0MHz	3.3V±10%	Square ACMOS 15pF	VoH ≥ 90% Vs VoL ≤ 10%Vs	3ns	3ns	45/55%	CFPT-9060
1.0MHz to 80.0MHz	5.0V±10%	Square ACMOS 15pF	VoH ≥ 90% Vs VoL ≤ 10%Vs	2ns	2ns	45/55%	CFPT-9055
8.0MHz to 50.0MHz	3.3V±10%	Clipped Sine 10kΩ//10pF	Vpk-pk ≥ 0.8V	—		—	CFPT-9061
8.0MHz to 50.0MHz	5.0V±10%	Clipped Sine 10kΩ//10pF	Vpk-pk ≥ 0.8V	—		—	CFPT-9057

SURFACE MOUNT
TCXOs

Operating Temperature Range	Frequency Stabilities Vs Operating Temperature Range					
	±0.3ppm	±0.5ppm	±1.0ppm	±1.5ppm	±2.0ppm	±2.5ppm
0 to 50°C	Code AP	Code EP	Code FP	Code CP	Code GP	Code HP
0 to 70°C	Code AC	Code EC	Code FC	Code CC	Code GC	Code HC
-20 to 70°C	Code AS*	Code ES	Code FS	Code CS	Code GS	Code HS
-30 to 75°C	—	Code EU	Code FU	Code CU	Code GU	Code HU
-40 to 85°C	—	Code EX*	Code FX	Code CX	Code GX	Code HX
-55 to 105°C	—	—	Code FY*	Code CY	Code GY	Code HY

Ordering Example	10.0MHz	CFPT-9051	CS	1	A
Frequency _____	_____	_____	_____	_____	_____
Model number _____	_____	_____	_____	_____	_____
Frequency Stability Vs Operating Temperature Code _____	_____	_____	_____	_____	_____
Reference Voltage Code _____	_____	_____	_____	_____	_____
Frequency Adjustment Code _____	_____	_____	_____	_____	_____

(For reference voltage and frequency adjustment codes see main text)

Note:* Codes may not be available for all frequencies

Europe Tel: +44 (0)1460 270200 Fax: +44 (0)1460 72578
 Americas Tel: +1 919 941 9333 Fax: +1 919 941 9371
 Asia Tel: +86 755 8826 5991 Fax: +86 755 8826 5990

Website: www.cmac.com

Lead Free Reflow Soldering Profile

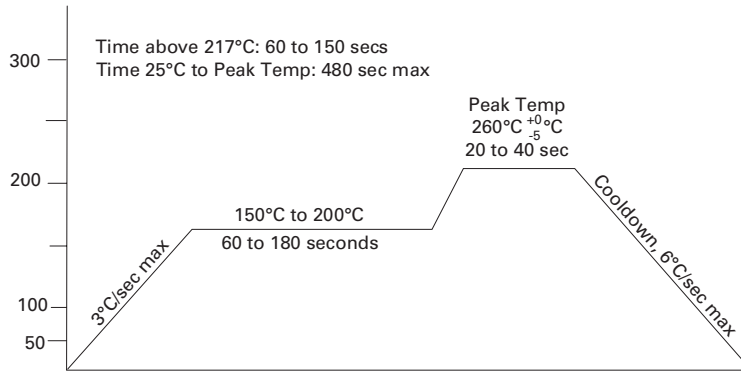

Tin / Lead Reflow Soldering Profile

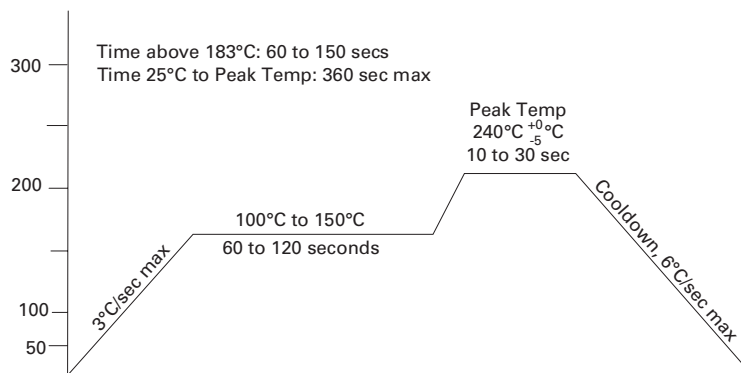

SURFACE MOUNT
TCXOs