

2N3715 JAN, JTX, JTXV

2N3716 JAN, JTX, JTXV



Processed per MIL-PRF-19500/408

NPN SILICON HIGH POWER TRANSISTOR

MAXIMUM RATINGS

Ratings	Symbol	2N3715	2N3716	Units
Collector-Emitter Voltage	V_{CEO}	60	80	Vdc
Collector-Base Voltage	V_{CBO}	80	100	Vdc
Emitter-Base Voltage	V_{EBO}	7.0		Vdc
Base Current	I_B	4.0		Adc
Collector Current	I_C	10		Adc
Total Power Dissipation @ $T_A = 25^{\circ}C$ @ $T_C = 100^{\circ}C$	P_T	5.0		W
		85.7		W
Operating & Storage Junction Temperature Range	T_J, T_{stg}	-65 to +200		$^{\circ}C$

THERMAL CHARACTERISTICS

Characteristics	Symbol	Max.	Unit
Thermal Resistance, Junction-to-Case	$R_{\theta JC}$	1.17	$^{\circ}C/W$

 1) Derate linearly 28.57 mW/ $^{\circ}C$ for $T_A > 25^{\circ}C$

 2) Derate linearly 0.857 W/ $^{\circ}C$ for $T_C > 100^{\circ}C$

ELECTRICAL CHARACTERISTICS ($T_C = 25^{\circ}C$ unless otherwise noted)

Characteristics	Symbol	Min.	Max.	Unit
-----------------	--------	------	------	------

OFF CHARACTERISTICS

Collector-Emitter Breakdown Current $I_C = 10$ mAdc	2N3715 2N3716	$V_{(BR)CEO}$	60 80	Vdc
Collector-Base Cutoff Current $V_{CB} = 80$ Vdc $V_{CB} = 100$ Vdc	2N3715 2N3716	I_{CBO}	10 10	μ Adc
Emitter-Base Breakdown Voltage $V_{EB} = 7.0$ Vdc		I_{EBO}	1.0	mAdc
Collector-Emitter Cutoff Current $V_{BE} = 1.5$ Vdc, $V_{CE} = 60$ Vdc $V_{BE} = 1.5$ Vdc, $V_{CE} = 80$ Vdc	2N3715 2N3716	I_{CEX}	1.0 1.0	mAdc

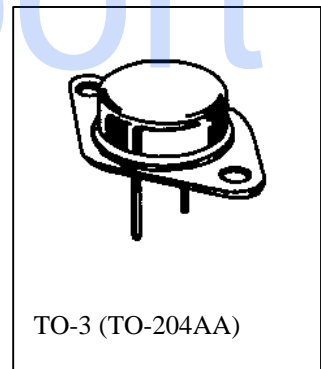

2N3715, 2N3716 JAN SERIES

ELECTRICAL CHARACTERISTICS (con't)

Characteristics	Symbol	Min.	Max.	Unit
Collector-Emitter Cutoff Current V _{CE} = 60 Vdc V _{CE} = 80 Vdc	I _{CES}		1.0 1.0	mAdc

ON CHARACTERISTICS ⁽³⁾

Forward-Current Transfer Ratio I _C = 1.0 Adc, V _{CE} = 2.0 Vdc I _C = 3.0 Adc, V _{CE} = 2.0 Vdc I _C = 5.0 Adc, V _{CE} = 2.0 Vdc I _C = 10 Adc, V _{CE} = 4.0 Vdc	h _{FE}	50 30 10 5.0	150 120	
Collector-Emitter Saturation Voltage I _C = 5.0 Adc, I _B = 0.5 Adc I _C = 10 Adc, I _B = 2.0 Adc	V _{CE(sat)}		1.0 2.5	Vdc
Base-Emitter Saturation Voltage I _C = 5.0 Adc, I _B = 0.5 Adc I _C = 10 Adc, I _B = 2.0 Adc	V _{BE(sat)}		1.5 3.0	Vdc

DYNAMIC CHARACTERISTICS

Magnitude of Common Emitter Small-Signal Short Circuit Forward Current Transfer Ratio I _C = 0.5 Adc, V _{CE} = 10 Vdc, f = 100 kHz – 1.0 MHz	h _{fe}	4.0	20	
Forward Current Transfer Ratio I _C = 0.5 Adc, V _{CE} = 10 Vdc, f = 1.0 kHz	h _{fe}	30	300	
Output Capacitance V _{CB} = 10 Vdc, I _E = 0, f = 1.0 MHz	C _{obo}		500	pF

SAFE OPERATING AREA

DC Tests T _C = +25°C, 1 Cycle, t ≥ 1.0 s				
Test 1 V _{CE} = 15 Vdc, I _C = 10 Adc				
Test 2 V _{CE} = 40 Vdc, I _C = 3.75 Adc				
Test 3 V _{CE} = 55 Vdc, I _C = 0.9 Adc 2N3715 V _{CE} = 65 Vdc, I _C = 0.9 Adc 2N3716				

(3) Pulse Test: Pulse Width = 300µs, Duty Cycle ≤ 2.0%.