

MIL-DTL-26482, Series 2, Matrix

BAYONET COUPLING CONNECTORS WITH CRIMP REAR RELEASE CONTACTS



J



TABLE OF CONTENTS FOR SECTION J

| | |
|---|--------|
| MIL-DTL-26482, Series 2, Matrix® | |
| Design Characteristics, Customer Options | 2 |
| Insert Availability and Identification, Alternate Positioning | 3 |
| Insert Arrangement Drawings | 4, 5 |
| Class Descriptions, Performance Specifications | 6 |
| How to Order (Military and Commercial) | 7 |
| Shell Styles: | |
| Wall Mounting Receptacle with Narrow Flange, Wall Mounting Receptacle with Wide Flange | 8 |
| Cable Connecting Receptacle, Jam Nut Receptacle | 9 |
| Straight Plug, Straight Plug with RFI Grounding Fingers | 10 |
| Contacts and Tools: | |
| Contact Information, Sealing Plugs, Crimping and Insertion/Removal Tools | 11 |
| Assembly Instructions | 12, 13 |

Design Characteristics and Options

AMPHENOL AEROSPACE OFFERS THE MATRIX® PRODUCT LINE OF MIL-DTL-26482*, SERIES 2 CONNECTORS

This series provides a bayonet coupling connector with crimp rear insertable, rear releasable contacts.

DESIGN CHARACTERISTICS

- Medium size, environmentally resistant connector
- Recommended operating voltage to 1,000 VAC (RMS) at sea level
- Quick positive coupling assured by 3 point bayonet coupling system
- Visual confirmation of complete coupling
- Eliminates mismatching by the use of five key/keyway design
- Insertion and removal of contacts from the rear of the connector assures no damage to the front that might affect the sealing characteristics
- Utilizes same standard qualified rear-release type plastic tool for contact insertion and removal
- Contacts are qualified to SAE AS39029** requirements – BIN coded (three color bands), and are crimped with standard crimp tools per MIL-DTL-22520
- Grommets are constructed of tear-resistant elastomer and experience no degradation when exposed to a broad range of fluids
- Sealing over a range of wire diameters is assured by a triple webbed grommet at the rear of the connector
- Closed entry socket side of the insert is designed with a lead-in chamfer and a hard face that will accept a pin contact bent within pre-established limits
- Elastomer interfacial seal on the pin side has raised barriers around each pin which displace into the socket chamfer when mated, providing a positive moisture seal

CUSTOMER OPTIONS

- Shell styles within this family include: Wall mount with either a narrow or a wide flange, jam nut single hole mount, and cable connecting receptacles, along with standard plugs or plugs with RFI grounding fingers, in shell sizes 8 to 24
- MS and Proprietary versions available
- Accommodation of contact sizes 20, 16 and 12
- 34 insert arrangement patterns available, accommodating from a minimum of 3 to a maximum of 55 circuits
- Alternate positioning available
- Various finishes are available (for information on non-cadmium zinc alloy plating, consult Amphenol Aerospace)

* MIL-DTL-26482 supersedes MIL-C-26482

** SAE AS39029 supersedes MIL-C-39029



**MS3470
WALL MOUNTING
RECEPTACLE
WITH NARROW
FLANGE
MS3472
WALL MOUNTING
RECEPTACLE**



**WITH WIDE FLANGE
MS3471
CABLE CONNECTING
RECEPTACLE**



**MS3474
JAM NUT RECEPTACLE**



**MS3476
STRAIGHT PLUG
MS3475
PLUG WITH RFI
GROUNDING
FINGERS**

INSERT ARRANGEMENTS

| Insert Arrangement | Service Rating | Total Contacts | Contact Size | | |
|--------------------|----------------|----------------|--------------|----|----|
| | | | 12 | 16 | 20 |
| 8-33 | I | 3 | | | 3 |
| 8-98 | I | 3 | | | 3 |
| 10-6 | I | 6 | | | 6 |
| 12-3 | II | 3 | | 3 | |
| 12-8 | I | 8 | | | 8 |
| 12-10 | I | 10 | | | 10 |
| 14-4 | I | 4 | 4 | | |
| 14-5 | II | 5 | | 5 | |
| 14-9 | I | 9 | 4 | | 5 |
| 14-12 | I | 12 | | 4 | 8 |
| 14-15 | I | 15 | | 1 | 14 |
| 14-18 | I | 18 | | | 18 |
| 14-19 | I | 19 | | | 19 |
| 16-8 | II | 8 | | 8 | |
| 16-23S | I | 23 | | 1 | 22 |
| 16-26 | I | 26 | | | 26 |
| 18-8 | I | 8 | 8 | | |
| 18-11 | II | 11 | | 11 | |
| 18-30 | I | 30 | | 1 | 29 |
| 18-32 | I | 32 | | | 32 |
| 20-16 | II | 16 | | 16 | |
| 20-24S | I | 24 | | | 24 |
| 20-39 | I | 39 | | 2 | 37 |
| 20-41 | I | 41 | | | 41 |
| 22-12 | I | 12 | 12 | | |
| 22-19S | I | 19 | 19 | | |
| 22-21 | II | 21 | | 21 | |
| 22-32S | I | 32 | | | 32 |
| 22-41 | I | 41 | | 14 | 27 |
| 22-55 | I | 55 | | | 55 |
| 22-95 | I | 32 | 6 | | 26 |
| 24-19S | II | 19 | 19 | | |
| 24-31 | I | 31 | | 31 | |
| 24-61 | I | 61 | | | 61 |

Arrangements designated with an S are tooled in socket only.

ALTERNATE ROTATIONS OF INSERT

To avoid cross-plugging problems in applications requiring the use of more than one connector of the same size and arrangement, alternate rotations are available as indicated in the chart below.

As shown in the diagram, the front face of the pin insert is rotated within the shell in a clockwise direction from the normal shell key. The socket insert would be rotated counter-clockwise the same number of degrees in respect to the normal shell key.

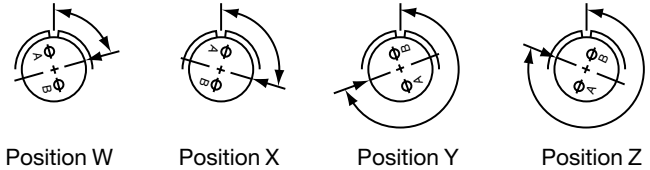

View looking into front face of pin insert or rear of socket insert.

| Insert Arrangement | Degrees | | | |
|--------------------|---------|-----|-----|-----|
| | W | X | Y | Z |
| 8-33 | 90 | - | - | - |
| 8-98 | - | - | - | - |
| 10-6 | 90 | - | - | - |
| 12-3 | - | - | 180 | - |
| 12-8 | 90 | 112 | 203 | 292 |
| 12-10 | 60 | 155 | 270 | 295 |
| 14-4 | 45 | - | - | - |
| 14-5 | 40 | 92 | 184 | 273 |
| 14-9 | 15 | 90 | 180 | 270 |
| 14-12 | 43 | 90 | - | - |
| 14-15 | 17 | 110 | 155 | 234 |
| 14-18 | 15 | 90 | 180 | 270 |
| 14-19 | 30 | 165 | 315 | - |
| 16-8 | 54 | 152 | 180 | 331 |
| 16-23 | 158 | 270 | - | - |
| 16-26 | 60 | - | 275 | 338 |
| 18-8 | 180 | - | - | - |
| 18-11 | 62 | 119 | 241 | 340 |
| 18-30 | 180 | 193 | 285 | 350 |
| 18-32 | 85 | 138 | 222 | 265 |
| 20-16 | 238 | 318 | 333 | 347 |
| 20-24 | 70 | 145 | 215 | 290 |
| 20-39 | 63 | 144 | 252 | 333 |
| 20-41 | 45 | 126 | 225 | - |
| 22-12 | - | - | - | - |
| 22-19 | 15 | 90 | 225 | 308 |
| 22-21 | 16 | 135 | 175 | 349 |
| 22-32 | 72 | 145 | 215 | 288 |
| 22-41 | 39 | 135 | 264 | - |
| 22-55 | 30 | 142 | 226 | 314 |
| 22-95 | 26 | 180 | 266 | - |
| 24-19 | 30 | 165 | 315 | - |
| 24-31 | 90 | 225 | 255 | - |
| 24-61 | 90 | 180 | 270 | 324 |

Insert Arrangements

Front face of pin insert or rear face of socket insert illustrated

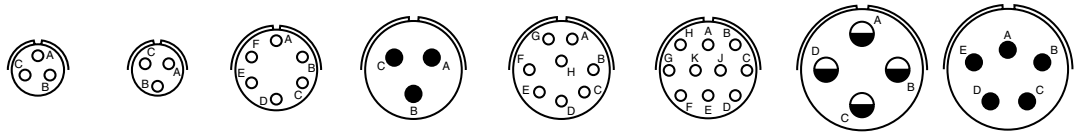

| Insert Arrangement | 8-33 | 8-98 | 10-06 | 12-03 | 12-08 | 12-10 | 14-04 | 14-05 |
|--------------------|------|------|-------|-------|-------|-------|-------|-------|
| Service Rating | I | I | I | II | I | I | I | II |
| Number of Contacts | 3 | 3 | 6 | 3 | 8 | 10 | 4 | 5 |
| Contact Size | 20 | 20 | 20 | 16 | 20 | 20 | 12 | 16 |

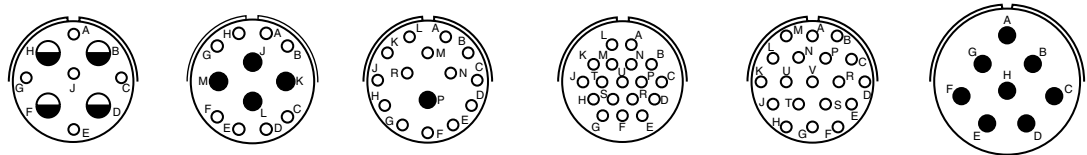

| Insert Arrangement | 14-09 | 14-12 | 14-15 | 14-18 | 14-19 | 16-08 | | | |
|--------------------|-------|-------|-------|-------|-------|-------|----|----|----|
| Service Rating | I | I | I | I | I | II | | | |
| Number of Contacts | 5 | 4 | 8 | 4 | 14 | 1 | 18 | 19 | 8 |
| Contact Size | 20 | 12 | 20 | 16 | 20 | 16 | 20 | 20 | 16 |

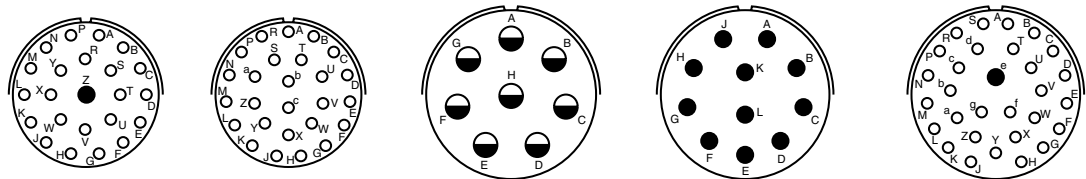

| Insert Arrangement | 16-23 | 16-26 | 18-08 | 18-11 | 18-30 | | |
|--------------------|-------|-------|-------|-------|-------|----|----|
| Service Rating | I | I | I | II | I | | |
| Number of Contacts | 22 | 1 | 26 | 8 | 11 | 29 | 1 |
| Contact Size | 20 | 16 | 20 | 12 | 16 | 20 | 16 |

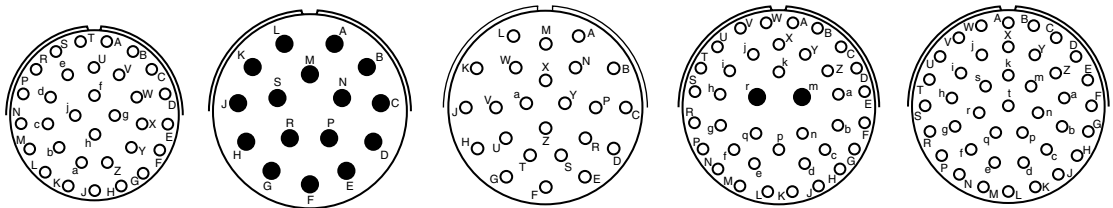

| Insert Arrangement | 18-32 | 20-16 | 20-24 | 20-39 | 20-41 | |
|--------------------|-------|-------|-------|-------|-------|----|
| Service Rating | I | II | I | I | I | |
| Number of Contacts | 32 | 16 | 24 | 37 | 2 | 41 |
| Contact Size | 20 | 16 | 20 | 20 | 16 | 20 |

NOTE: Connectors sold as mil-spec connectors will have mil-spec markings on the insert (a "snail-trail" designating the numerical path). Commercial versions will have insert markings as shown here.

CONTACT LEGEND

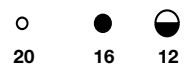

Insert Arrangements

Front face of pin insert or rear face of socket insert illustrated

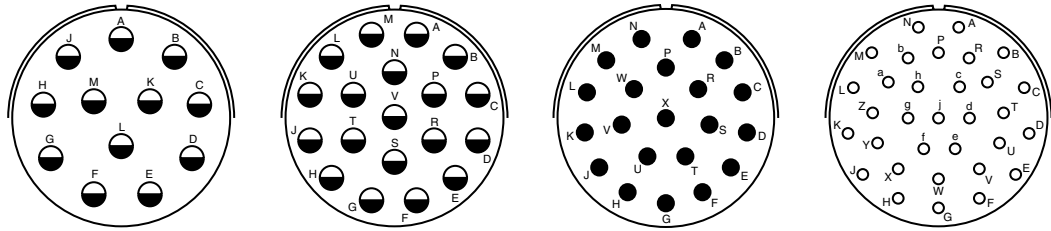

| Insert Arrangement | 22-12 | 22-19 | 22-21 | 22-32 |
|--------------------|-------|-------|-------|-------|
| Service Rating | I | I | II | I |
| Number of Contacts | 12 | 19 | 21 | 32 |
| Contact Size | 12 | 12 | 16 | 20 |

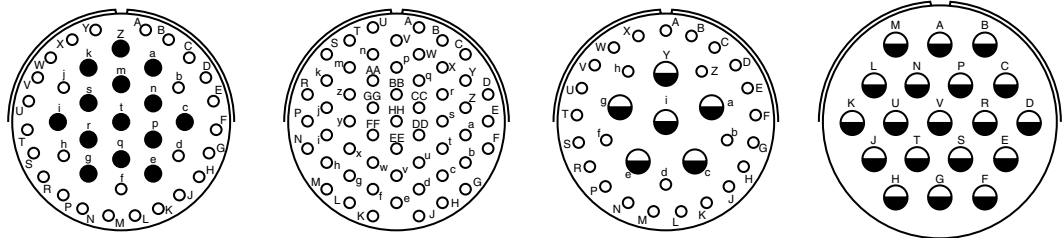

| Insert Arrangement | 22-41 | | 22-55 | 22-95 | | 24-19 |
|--------------------|-------|----|-------|-------|----|-------|
| Service Rating | I | | I | I | | II |
| Number of Contacts | 27 | 14 | 55 | 26 | 6 | 19 |
| Contact Size | 20 | 16 | 20 | 20 | 12 | 12 |

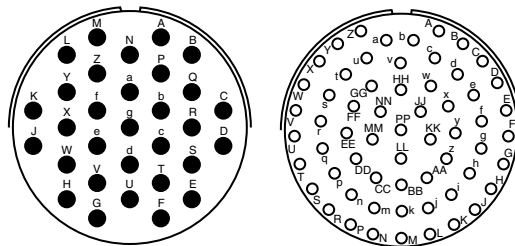

| Insert Arrangement | 24-31 | 24-61 |
|--------------------|-------|-------|
| Service Rating | I | I |
| Number of Contacts | 31 | 61 |
| Contact Size | 16 | 20 |

NOTE: Connectors sold as mil-spec connectors will have mil-spec markings on the insert (a "snail-trail" designating the numerical path). Commercial versions will have insert markings as shown here.

CONTACT LEGEND

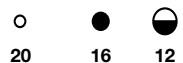

26482

MATRIX 2



Class Descriptions, Performance Specifications

CLASS DESCRIPTIONS

| Military MIL-DTL-26482, Series 2 | Amphenol/Matrix Commercial MB1 Series | Description |
|----------------------------------|---------------------------------------|---|
| Class L | Class R | Aluminum shell, electroless nickel finish, fluid resistant |
| Class E | – | Inactive, superceded by Class L* |
| Class R | – | Inactive, superceded by Class L* |
| Class A | Class A | Aluminum shell, black non-conductive anodized finish, fluid resistant |
| – | Class G | Stainless steel shell, passivated, fluid resistant |
| Class W | Class W | Aluminum shell, olive drab cadmium plated, corrosion/fluid resistant |

* Ref. MIL-DTL-26482

PERFORMANCE SPECIFICATIONS

SERVICE RATINGS**

| Service Rating | Recommended Operating AC Voltage at Sea Level | Test Voltage AC (RMS), 60 cps | | | |
|----------------|---|-------------------------------|------------|------------|-------------|
| | | Sea Level | 50,000 ft. | 70,000 ft. | 110,000 ft. |
| I | 600 | 1,500 | 500 | 375 | 200 |
| II | 1,000 | 2,300 | 750 | 500 | 200 |

** Service Rating is comparable to MS rating A. Miniature connectors rated Service Rating I will provide a minimum flashover voltage at sea level of 2,000 volts AC (RMS). Service Rating II is comparable to MS Service Rating D, and will provide a minimum flashover voltage of 2,800 volts AC (RMS) at sea level.

Please note that the electrical data given is not an establishment of electrical safety factors. This is left entirely in the designer's hands, as he can best determine which peak voltage, switching surges, transients, etc. can be expected in a particular circuit.

OPERATING TEMPERATURE RANGE

–65°C (–85°F) to 200°C (392°F)

ENVIRONMENTAL SEAL

Wired, mated connectors with the specified accessory attached will meet the altitude immersion test specified in MIL-DTL-26482.

DURABILITY

Minimum of 500 mating cycles.

SHOCK AND VIBRATION REQUIREMENTS

When tested as follows, the connector shall sustain no physical damage, or electrical discontinuity exceeding one microsecond.

SHOCK:

Pulse of an approximate half sine wave of 300g magnitude with duration of 3 milliseconds applied in three axes.

VIBRATION:

Sixteen hours of random vibration having a range of 50 to 2,000 Hz with a 41.7G peak level.

| | 1. | 2. | 3. | 4. | 5. | 6. | 7. |
|-------------------------|----------------|-----------------|---------------|-------------------------------|--------------|------------------------------|---------------------|
| MIL-DTL-26482, Series 2 | Connector Type | Connector Style | Service Class | Shell Size/Insert Arrangement | Contact Type | Alternate Rotation of Insert | Modification Number |
| MILITARY | MS | 3470 | W | 12-10 | P | W | NA |
| COMMERCIAL | MB1 | 0 | W | 12-10 | P | W | (xxx) |

1. MILITARY CONNECTOR TYPE

MS Designates Military Standard

2. CONNECTOR STYLE

| | |
|-------------|--|
| 3470 | Wall mount receptacle with narrow flange |
| 3472 | Wall mount receptacle with wide flange |
| 3471 | Cable connecting receptacle |
| 3474 | Jam nut receptacle |
| 3476 | Straight plug |
| 3475 | Straight plug with RFI grounding fingers |

3. SERVICE CLASS

| | |
|----------|--|
| L | Aluminum shell, electroless nickel finish, fluid resistant insert |
| A | Aluminum shell, black anodized finish, non-conductive fluid resistant insert |
| W | Aluminum shell, olive drab cadmium plated, fluid resistant insert |

Note: For stainless steel shell, passivated, order by Amphenol®/Matrix® commercial Class G. Class L inactivates classes E and R (Ref. MIL-DTL-26482)

4. SHELL SIZE & INSERT ARRANGEMENT FROM CHART ON PAGE J3.

First number represents Shell Size, second number is the Insert Arrangement.

5. CONTACT TYPE

| | |
|----------|-----------------|
| P | Pin contacts |
| S | Socket contacts |
| A | Less pins |
| B | Less sockets |

Use A & B only when other than a full complement of power contacts is to be installed.

6. ALTERNATE ROTATION OF INSERT

“W”, “X”, “Y”, “Z” designate that insert is rotated in its shell from normal position. No letter required for normal (no rotation) position. See page J3 for description of alternate positions. For ordering information on accessories, such as protection caps and backshell hardware, contact Amphenol Aerospace.

1. COMMERCIAL CONNECTOR TYPE

MB1 Designates Amphenol®/Matrix® Bayonet Coupling Connector

2. CONNECTOR STYLE

| | |
|----------|--|
| 0 | Wall mount receptacle with narrow flange |
| 1 | Wall mount receptacle with wide flange |
| 3 | Cable connecting receptacle |
| 4 | Jam nut receptacle |
| 6 | Straight plug |
| 8 | Straight plug with RFI grounding fingers |

3. SERVICE CLASS

| | |
|-----------|--|
| A | Aluminum shell, black anodized finish, non-conductive, fluid resistant insert |
| B | Black zinc conductive plating. Must also add modification number (A15) in step 7 |
| C | Green zinc cobalt plating. Must also add modification number (981) in step 7 |
| R | Aluminum shell, electroless nickel finish, fluid resistant insert |
| G | Stainless steel shell, passivated, fluid resistant insert |
| W | Aluminum shell, cadmium plated, olive drab finish, fluid resistant insert |
| DZ | Black zinc nickel |
| DT | Durmalon |

4. SHELL SIZE & INSERT ARRANGEMENT FROM CHART ON PAGE J3.

First number represents Shell Size, second number is the Insert Arrangement.

5. CONTACT TYPE

| | |
|----------|-----------------|
| P | Pin contacts |
| S | Socket contacts |

6. ALTERNATE ROTATION OF INSERT

“W”, “X”, “Y”, “Z” designate that insert is rotated in its shell from normal position. No letter required for normal (no rotation) position. See page J3 for description of alternate positions.

7. MODIFICATION NUMBER

| | |
|--------------|--|
| (189) | E-nut M85049/31 configuration |
| (190) | Straight strain relief M85049/52 configuration |
| (191) | 90° strain relief M85049/51 configuration |
| (A15) | Used with finish class B to designate conductive black zinc plating. |
| (981) | Used with finish class C to designate green zinc cobalt plating. |

Wall Mounting Receptacle (with Narrow Flange)

Military (MS3470), Commercial (MB10)

PART NUMBER BUILDER Page J7

MILITARY
MS3470

Commercial
MB10

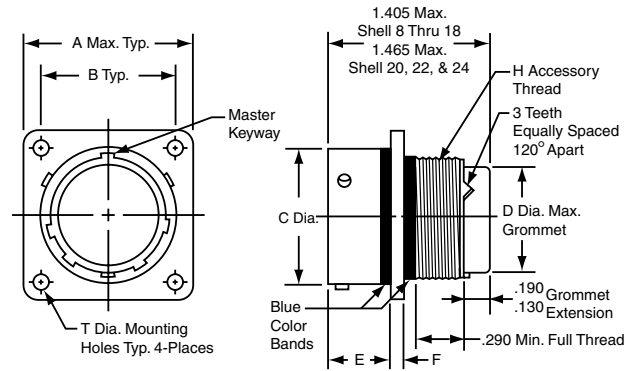

| Shell Size | A Max. | B ±.005 | C Dia. ±.003 | D Dia. Max. | E | F ±.016 | H Accessory Thread Class 2A | T Dia. ±.005 |
|------------|--------|---------|--------------|-------------|-----------|---------|-----------------------------|--------------|
| 8 | .828 | .594 | .471 | .305 | .462/.431 | .062 | .5000-20 UNF | .120 |
| 10 | .954 | .719 | .588 | .405 | .462/.431 | .062 | .6250-24 UNEF | .120 |
| 12 | 1.047 | .812 | .748 | .531 | .462/.431 | .062 | .7500-20 UNEF | .120 |
| 14 | 1.141 | .906 | .873 | .665 | .462/.431 | .062 | .8750-20 UNEF | .120 |
| 16 | 1.234 | .969 | .998 | .790 | .462/.431 | .062 | 1.0000-20 UNEF | .120 |
| 18 | 1.328 | 1.062 | 1.123 | .869 | .462/.431 | .062 | 1.0625-18 UNEF | .120 |
| 20 | 1.453 | 1.156 | 1.248 | .994 | .587/.556 | .094 | 1.1875-18 UNEF | .120 |
| 22 | 1.578 | 1.250 | 1.373 | 1.119 | .587/.556 | .094 | 1.3125-18 UNEF | .120 |
| 24 | 1.703 | 1.375 | 1.498 | 1.244 | .620/.589 | .094 | 1.4375-18 UNEF | .147 |

All dimensions for reference only.

Wall Mounting Receptacle (with Wide Flange)

Military (MS3472), Commercial (MB11)

PART NUMBER BUILDER Page J7

MILITARY
MS3472

Commercial
MB11

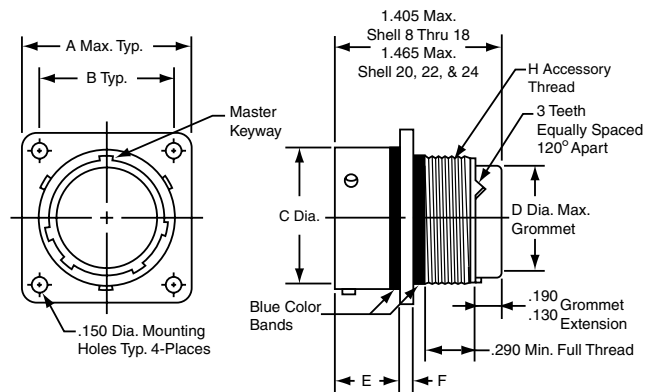

| Shell Size | A Max. | B ±.005 | C Dia. ±.003 | D Dia. Max. | E | F ±.016 | H Accessory Thread Class 2A |
|------------|--------|---------|--------------|-------------|-----------|---------|-----------------------------|
| 8 | 1.065 | .734 | .471 | .305 | .493/.462 | .062 | .5000-20 UNF |
| 10 | 1.141 | .812 | .588 | .405 | .493/.462 | .062 | .6250-24 UNEF |
| 12 | 1.266 | .938 | .748 | .531 | .493/.462 | .062 | .7500-20 UNEF |
| 14 | 1.360 | 1.031 | .873 | .665 | .493/.462 | .062 | .8750-20 UNEF |
| 16 | 1.453 | 1.125 | .998 | .790 | .493/.462 | .062 | 1.0000-20 UNEF |
| 18 | 1.532 | 1.203 | 1.123 | .869 | .493/.462 | .062 | 1.0625-18 UNEF |
| 20 | 1.688 | 1.297 | 1.248 | .994 | .587/.556 | .094 | 1.1875-18 UNEF |
| 22 | 1.766 | 1.375 | 1.373 | 1.119 | .587/.556 | .094 | 1.3125-18 UNEF |
| 24 | 1.891 | 1.500 | 1.498 | 1.244 | .620/.589 | .094 | 1.4375-18 UNEF |

All dimensions for reference only.

26482

MATRIX 2

Cable Connecting Receptacle

Military (MS3471), Commercial (MB13)

PART NUMBER BUILDER Page J7

MILITARY
MS3471

Commercial

MB13

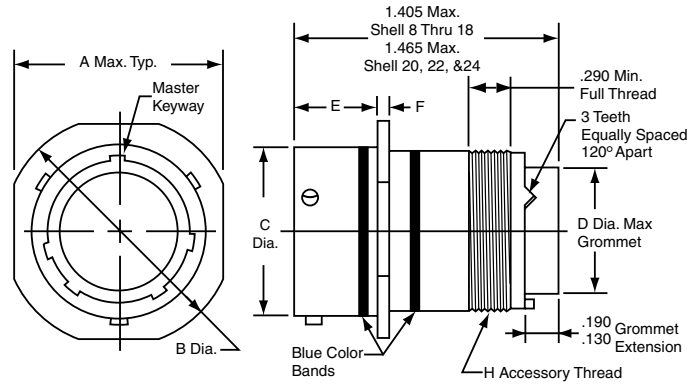

| Shell Size | A Max. | B Dia. ±.020 | C Dia. ±.003 | D Dia. Max. | E | F ±.016 | H Accessory Thread Class 2A |
|------------|--------|--------------|--------------|-------------|-----------|---------|-----------------------------|
| 8 | .828 | .938 | .471 | .305 | .462/.431 | .062 | .5000-20 UNF |
| 10 | .954 | 1.062 | .588 | .405 | .462/.431 | .062 | .6250-24 UNEF |
| 12 | 1.047 | 1.156 | .748 | .531 | .462/.431 | .062 | .7500-20 UNEF |
| 14 | 1.141 | 1.250 | .873 | .665 | .462/.431 | .062 | .8750-20 UNEF |
| 16 | 1.234 | 1.344 | .998 | .790 | .462/.431 | .062 | 1.0000-20 UNEF |
| 18 | 1.328 | 1.438 | 1.123 | .869 | .462/.431 | .062 | 1.0625-18 UNEF |
| 20 | 1.453 | 1.562 | 1.248 | .994 | .587/.556 | .094 | 1.1875-18 UNEF |
| 22 | 1.578 | 1.688 | 1.373 | 1.119 | .587/.556 | .094 | 1.3125-18 UNEF |
| 24 | 1.703 | 1.812 | 1.498 | 1.244 | .620/.589 | .094 | 1.4375-18 UNEF |

All dimensions for reference only.

Jam Nut Receptacle

Military (MS3474), Commercial (MB14)

PART NUMBER BUILDER Page J7

MILITARY
MS3474

Commercial

MB14

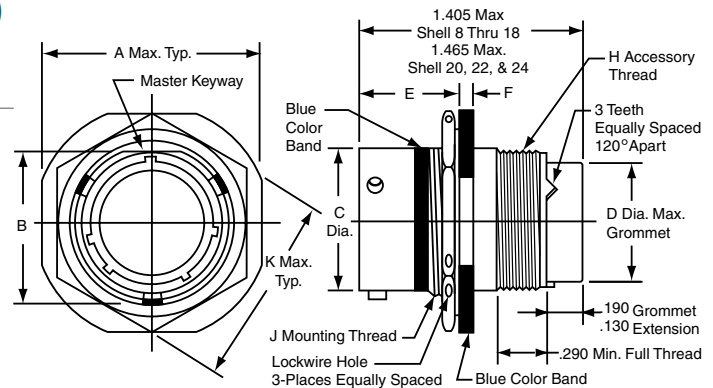

| Shell Size | A Max. | B ±.005 | C Dia. ±.003 | D Dia. Max. | E | F | H Accessory Thread Class 2A | J Mounting Thread Class 2A | K Max. |
|------------|--------|---------|--------------|-------------|-----------|-----------|-----------------------------|----------------------------|--------|
| 8 | .954 | .525 | .471 | .305 | .707/.658 | .113/.086 | .5000-20 UNF | .5625-24 UNEF | .767 |
| 10 | 1.078 | .650 | .588 | .405 | .707/.658 | .113/.086 | .6250-24 UNF | .6875-24 UNEF | .892 |
| 12 | 1.266 | .813 | .748 | .531 | .707/.658 | .113/.086 | .7500-20 UNEF | .8750-20 UNEF | 1.079 |
| 14 | 1.391 | .937 | .873 | .665 | .707/.658 | .113/.086 | .8750-20 UNEF | 1.0000-20 UNEF | 1.205 |
| 16 | 1.516 | 1.061 | .998 | .790 | .707/.658 | .113/.086 | 1.0000-20 UNEF | 1.1250-18 UNEF | 1.329 |
| 18 | 1.641 | 1.186 | 1.123 | .869 | .707/.658 | .113/.086 | 1.0625-18 UNEF | 1.2500-18 UNEF | 1.455 |
| 20 | 1.828 | 1.311 | 1.248 | .994 | .772/.721 | .148/.096 | 1.1875-18 UNEF | 1.3750-18 UNEF | 1.579 |
| 22 | 1.954 | 1.436 | 1.373 | 1.119 | .772/.721 | .148/.096 | 1.3125-18 UNEF | 1.5000-18 UNEF | 1.705 |
| 24 | 2.078 | 1.561 | 1.498 | 1.244 | .772/.721 | .148/.096 | 1.4375-18 UNEF | 1.6250-18 UNEF | 1.829 |

All dimensions for reference only.

Straight Plug

Military (MS3476), Commercial (MB16)

PART NUMBER BUILDER Page J7

MILITARY
MS3476

Commercial

MB16

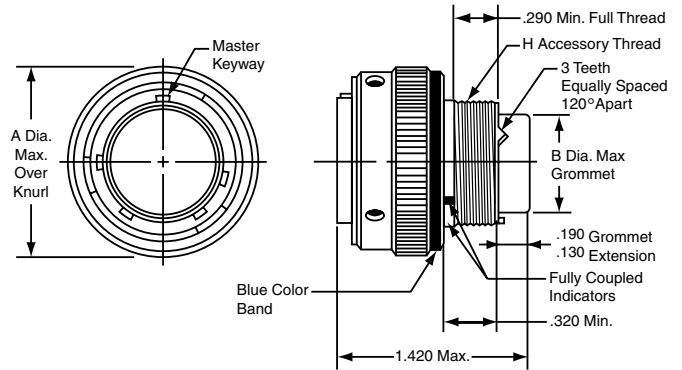

| Shell Size | A Dia. Max. | B Dia. Max. | H Accessory Thread Class 2A |
|------------|-------------|-------------|-----------------------------|
| 8 | .782 | .305 | .5000-20 UNF |
| 10 | .926 | .405 | .6250-24 UNEF |
| 12 | 1.043 | .531 | .7500-20 UNEF |
| 14 | 1.183 | .665 | .8750-20 UNEF |
| 16 | 1.305 | .790 | 1.0000-20 UNEF |
| 18 | 1.391 | .869 | 1.0625-18 UNEF |
| 20 | 1.531 | .994 | 1.1875-18 UNEF |
| 22 | 1.656 | 1.119 | 1.3125-18 UNEF |
| 24 | 1.777 | 1.244 | 1.4375-18 UNEF |

All dimensions for reference only.

Straight Plug (With RFI Grounding Fingers)

Military (MS3475), Commercial (MB18)

PART NUMBER BUILDER Page J7

MILITARY
MS3475

Commercial

MB18

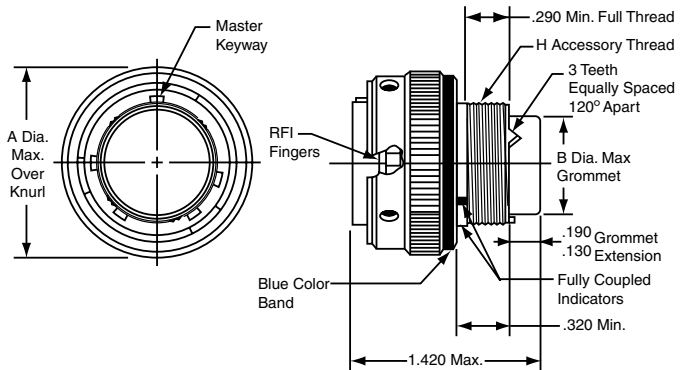

| Shell Size | A Dia. Max. | B Dia. Max. | H Accessory Thread Class 2A |
|------------|-------------|-------------|-----------------------------|
| 8 | .782 | .305 | .5000-20 UNF |
| 10 | .926 | .405 | .6250-24 UNEF |
| 12 | 1.043 | .531 | .7500-20 UNEF |
| 14 | 1.183 | .665 | .8750-20 UNEF |
| 16 | 1.305 | .790 | 1.0000-20 UNEF |
| 18 | 1.391 | .869 | 1.0625-18 UNEF |
| 20 | 1.531 | .994 | 1.1875-18 UNEF |
| 22 | 1.656 | 1.119 | 1.3125-18 UNEF |
| 24 | 1.777 | 1.244 | 1.4375-18 UNEF |

All dimensions for reference only.

26482

MATRIX 2

Contact Information, Sealing Plugs, Crimping and Insertion/Removal Tools

CRIMP CONTACTS

| Contact Size | Wire Range | | Socket Contacts | | Pin Contacts | |
|--------------|------------|-----------------|----------------------|-----------------------------|----------------------|-----------------------------|
| | AWG | mm ² | Military Part Number | Amphenol/Matrix Part Number | Military Part Number | Amphenol/Matrix Part Number |
| 20 | 24-20 | 0.2-0.6 | M39029/5-115 | M5100-001-0020L | M39029/4-110 | M5000-054-0020L |
| 16 | 20-16 | 0.5-1.4 | M39029/5-116 | M5100-001-0016L | M39029/4-111 | M5000-054-0016L |
| 12 | 14-12 | 2-3 | M39029/5-118 | M5100-001-0012L | M39029/4-113 | M5000-054-0012L |

CONTACT CURRENT RATING AND RETENTION

| Contact Size* | DC Test Amperage | Contact Retention | |
|---------------|------------------|-------------------|-------|
| | | Axial Load | |
| | | lb. | N |
| 20 | 7.5 | 20 | 89.0 |
| 16 | 13.0 | 25 | 111.2 |
| 12 | 23.0 | 30 | 133.4 |

* Organize individual circuits to maintain heat rise within operating temperature requirements.

SEALING PLUGS

| Contact Size | Sealing Plugs | |
|--------------|----------------------|-----------------------------|
| | Military Part Number | Amphenol/Matrix Part Number |
| 20 | MS27488-20-2 | 10-405996-202 |
| 16 | MS27488-16-2 | 10-405996-162 |
| 12 | MS27488-12-2 | 10-405996-122 |

CRIMPING TOOLS

| Contact Size | Wire Range | | Finished Wire Dia. Range | | Crimping Tool Part Number | Turret or Positioner Part Number |
|--------------|------------|-----------------|--------------------------|-----------|----------------------------|----------------------------------|
| | AWG | mm ² | Inch | mm | | |
| 20 | 24-20 | 0.2-0.6 | .040-.083 | 1.02-2.11 | M22520/1-01 or M22520/2-01 | M22520/1-02 or M22520/2-02 |
| 16 | 20-16 | 0.5-1.4 | .053-.103 | 1.34-2.62 | M22520/1-01 | M22520/1-02 |
| 12 | 14-12 | 2-3 | .097-.158 | 2.46-4.01 | M22520/1-01 | M22520/1-02 |

INSERTION/REMOVAL TOOLS

| Contact Size | Color Code | Military Part Number | Amphenol/Matrix Part Number |
|--------------|--------------|----------------------|-----------------------------|
| 20 | Red/White | M81969/14-11 | 10-538988-201 |
| 16 | Blue/White | M81969/14-03 | 10-538988-016 |
| 12 | Yellow/White | M81969/14-04 | 10-538988-012 |

Note: Each connector is furnished with contacts. One spare for inserts requiring 1 to 26 of each contact, two spares for inserts with more than 26 contacts, and a minimum of one sealing plug up to 15% of the number of contacts.

Assembly Instructions

Military (MS3476), Commercial (MB16)

WIRE STRIPPING

- Strip wire to required length. (See Figure at right). When using hot wire stripping do not wipe melted insulation material on wire strands; with mechanical strippers do not cut or nick strands.
 - See Table 1 for proper finished outside wire dimensions.
 - Twist strands together to form a firm bundle.
 - Insert stripped wire into contact applying slight pressure until wire insulation butts against wire well. Check inspection hole to see that wire strands are visible. If there are strayed wire strands, entire wire end should be re-twisted.
- When wire is stripped and properly installed into contact, the next step is to crimp the wire inside the contact by using the proper crimping tool.

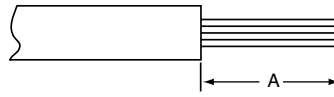

STRIPPING DIMENSIONS

| Wire Size | A |
|-----------|-------------|
| 20 | .188 (4.77) |
| 16 | .188 (4.77) |
| 12 | .188 (4.77) |

TABLE 1

| Contact Size | Wire Dimension (inches)** | |
|--------------|---------------------------|------|
| | Min. | Max. |
| 12 | .040 | .083 |
| 16 | .053 | .103 |
| 20 | .097 | .153 |

** Min. diameters to ensure moisture proof assembly; max. diameters to permit use of metal removal tools.

CRIMPING

See table on preceding page for recommended M22520 series crimping tools, turret head or positioner selection settings according to contact size, part number and wire gauge size.

- Insert stripped wire into contact crimp pot. Wire must be visible through inspection hole.
- Using correct crimp tool and locator, cycle the tool once to be sure the indentors are open, insert contact and wire into locator. Squeeze tool handles firmly and completely to insure a proper crimp. The tool will not release unless the crimp indentors in the tool head have been fully actuated.
- Release crimped contact and wire from tool. Be certain the wire is visible through inspection hole in contact.

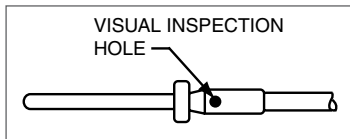

Example M22520 Series Crimping Tool for size 20, 16 or 12 contacts, and has a positioner that can be dialed for each contact size.

CONTACT INSERTION

- First remove hardware from the plug and receptacle and slide the hardware over wires in proper sequence.

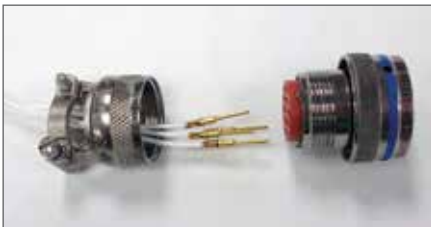

- Use proper plastic or metal insertion tool for corresponding contact. (Consult tool table on preceding page). Slide correct tool (with plastic tool use colored end) over wire insulation and slide forward until tool bottoms against rear contact shoulder.



Plastic tool with contact in proper position.

- Next align the tool and contact up to the properly identified cavity at rear of connector plug. Use firm, even pressure; do not use excessive pressure. It is recommended to start at the center cavity. Contact must be aligned with grommet hole and not inserted at an angle. Push forward until contact is felt to snap into position within insert.



Note: All plastic tools are double-ended. The colored side is the insertion tool and the white side is the removal tool.



Metal tool with contact.

Continued on next page.

Assembly Instructions

Military (MS3476), Commercial (MB16)

CONTACT INSERTION, CONT.

4. Remove tool and pull back lightly on wire, making sure contact stays properly seated and isn't dragged back with the tool. Repeat operation with remainder of contacts to be inserted, beginning with the center cavity and working outward in alternating rows.



5. After all contacts are inserted, fill any empty cavities with wire sealing plugs. (Refer to sealing plug charts for Series III on page 18, for Series I, II, and SJT on page 19.)

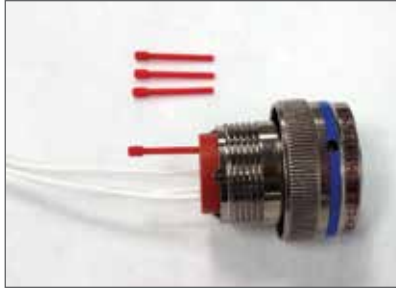

6. Reassemble plug or receptacle hardware - slide forward and tighten using connector pliers. Connector holding tools are recommended while tightening back accessories. When using strain relief, center wires at bar clamp. Slide clamp grommet into position and tighten clamp bar screws. When tightening screws, pressure should be applied in the same direction that clamp is threaded to rear threads of connector. When not using clamp grommet, build up wire bundle with vinyl tape so clamp bar will maintain pressure on wires.



CAUTION when inserting or removing contacts, do not spread or rotate tool tips.

CONTACT REMOVAL

1. Remove hardware from plug or receptacle and slide hardware back along wire bundle.



2. Use proper plastic or metal removal tool for corresponding contact. (Consult tool table on page 277). Slide correct size tool over wire insulation.



Use white end of plastic tool for removal of contacts.

3. Insert plastic or metal removal tool into contact cavity until tool tips enter rear grommet and come to a positive stop. Hold tool tip firmly against positive stop on contact shoulder. Grip wire and simultaneously remove tool and contact. (On occasion, it may be necessary to remove tool, rotate 90° and reinsert.)



Removal of contacts with metal tool.

