

simodrive

sensor

Measuring System for Main Spindle Drives  
SIMAG H

**SIEMENS**



## **SIMODRIVE sensor – SIMAG H Measuring System for Main Spindle Drives**

### **Planning/Installation Guide**

General Information	1
Description of Components	2
Technical Data	3
Installation / Calibration	4
Assembly Drawing	5

# SIMODRIVE® Documentation

## Printing history

Brief details of this edition and previous editions are listed below.

The status of each edition is shown by the code in the "Remarks" column.

*Status code in the "Remarks" column:*

- A . . . . . New documentation
- B . . . . . Unrevised reprint with new Order No.
- C . . . . . Revised edition with new status.

If factual changes have been made on the page since the last edition, this is indicated by a new edition coding in the header on that page.

<b>Edition</b>	<b>Order No.</b>	<b>Remarks</b>
05.99	6SN1 197-0AB30-0BP0	<b>A</b>
07.02	6SN1 197-0AB30-0BP1	<b>C</b>

This manual is part of the documentation on CD-ROM (**DOCONCD**)

<b>Edition</b>	<b>Order No.</b>	<b>Remarks</b>
11.02	6FC5 298-6CA00-0BG3	<b>C</b>

## Trademarks

SIMATIC®, SIMATIC HMI®, SIMATIC NET®, SIROTEC®, SINUMERIK®, SIMODRIVE® and MOTION-CONNECT® are Siemens trademarks. All other product and system names are registered trademarks of their respective owners and must be treated accordingly.

Further information is available on the Internet under:  
<http://www.ad.siemens.de/simodrive>

This publication was produced with Interleaf V 7

The reproduction, transmission or use of this document or its contents is not permitted without express written authorization. Offenders will be liable for damages. All rights, including rights created by patent grant or registration of a utility model or design, are reserved.

© Siemens AG 2002. All rights reserved.

Other functions not described in this documentation might be executable in the control. This does not, however, represent an obligation to supply such functions with a new control or when servicing.

We have checked that the contents of this publication agree with the hardware and software described herein. Nonetheless, differences might exist and therefore we cannot guarantee that they are completely identical. The information given in this publication is reviewed at regular intervals and any corrections that might be necessary are made in the subsequent printings. Suggestions for improvement are welcome at all times.

Subject to change without prior notice.

# Preface

This document is part of the documentation developed for SIMODRIVE. All publications are available individually. The documentation list, which includes all Advertising Brochures, Catalogs, Overviews, Short Descriptions, User Manuals and Technical Descriptions can be obtained from your local Siemens office (with Order No.).

This Guide does not purport to cover all details or variations in equipment, nor to provide for every possible contingency to be met in connection with installation, operation or maintenance. Should further information be desired or should particular problems arise which are not covered sufficiently for the purchaser's purposes, the matter should be referred to the local Siemens office. The contents of this Guide shall neither become part of nor modify any prior or existing agreement, commitment or relationship. The Sales Contract contains the entire obligations of Siemens. The warranty contained in the contract between the parties is the sole warranty of Siemens. Any statements contained herein do not create new warranties or modify the existing warranty.

## Hotline

If you have any questions, please contact the following Hotline:

A&D Technical Support	Tel: +49 (180) 50 50 222
	FAX: +49 (180) 50 50 223
	eMail: <a href="mailto:adsupport@siemens.com">adsupport@siemens.com</a>

If you have any questions regarding the documentation (also suggestions, corrections), please send a fax to the following number:

+49 (9131) 98-2176

Fax form: refer to the suggestion sheet the end of this brochure.

## Definition of qualified personnel

For the purpose of this Guide and product labels, a "qualified person" is one who is familiar with the installation, mounting, start-up and operation of the equipment and the hazards involved. He or she must have the following qualifications:

- Trained and authorized to energize, de-energize, ground and tag circuits and equipment in accordance with established safety procedures.
- Trained in the proper care and use of protective equipment in accordance with established safety procedures.
- Trained in rendering first aid.

## Explanation of the various symbols



---

### **Danger**

This symbol in the document indicates that death, severe physical injury or substantial property damage will result if proper precautions are not taken.

---



---

### **Warning**

This symbol appears in the document if death, severe physical injury or property damage can result if proper precautions are not taken.

---



---

### **Caution**

This symbol appears in the document indicating that minor physical injury or property damage can result if proper precautions are not taken.

---

---

### **Caution**

This warning (without warning triangle) indicates that material damage **can** result if the proper precautions are not taken.

---

---

### **Notice**

This warning indicates that an undesirable situation or condition **can** occur if the appropriate instructions/information are not observed.

---

---

### **Note**

We recommend that this information is observed

---

## Danger and warning information



---

### Danger

- Start-up/commissioning is prohibited until it has been ensured that the machine, in which the components described here are to be installed, fulfills the regulations/specifications of the Directive 98/37/EC.
  - Only appropriately qualified personnel may commission/start-up this equipment.
  - This personnel must observe the technical customer documentation relevant to the product and the observe the danger and warning information.
  - Operational electrical equipment has parts and components which are at hazardous voltage levels.
  - Hazardous axis motion can occur when working with the equipment.
  - All work should be undertaken with the system in a no-voltage condition
- 



---

### Warning

- Perfect, safe and reliable operation of this equipment assumes that it has been professionally transported, stored, mounted and installed as well as careful operator control and service.
  - The information given in catalogs and quotations applies additionally for special versions of machines and equipment.
  - In addition to the danger and warning information in the technical customer documentation supplied with the equipment, all relevant national, local and plant-specific regulations and specifications must also be taken into account.
- 





---

### Caution

- For synchronous motors, voltage is present at the motor terminals when the rotor is turning (integrated permanent magnets).
  - Surface temperatures of over +100° C can occur on the motors. For this reason, no heat-sensitive objects, such as cables or electronic components, may be attached to or come into contact with the motor surface.
  - When handling cables, please observe the following:
    - They must not be damaged
    - They must not be stressed
    - They must not come into contact with rotating components.
-

## ESDS information

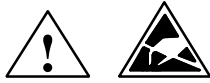
---



### Caution

Electrostatic dischargesensitive devices are individual components, integrated circuits, or boards which when handled, tested or transported, could be destroyed by electrostatic fields or electrostatic discharge. These components are designated as **ESDS** (ElectroStatic Discharge Sensitive Devices).

Handling ESDS boards:

- The human body, working area and packing should be well grounded when handling ESDS components!
  - Electronic boards may only be touch by personnel in ESDS areas with conductive floor surface if
    - they are grounded with an ESDS bracelet
    - they are wearing ESDS shoes or ESDS shoe grounding strips.
  - Boards should only be touched when absolutely necessary.
  - Electronic modules and boards may neither come into contact with plastic materials nor man-made fibers
  - Boards may only be placed on conductive surfaces (desk with ESDS surface, conductive ESDS foam rubber, ESDS packing bag, ESDS transport containers).
  - Boards may not be brought close to data terminals, monitors or television sets.  
A minimum of 10 cm should be kept between the board and the screen.
  - Measurements may be taken on the boards only if
    - the measuring equipment is grounded (e.g. via the protective conductor)  
or
    - in the case of floating measuring instruments, the probe is briefly discharged before a measurement is taken (e.g. through contact with bare control housing).
-



---

**Note**

For technical information about the SIMODRIVE 611, please refer to the following Guides:

SIMODRIVE 611, Planning Guide

Transistor PWM Inverters for AC Feed Drives and AC Main Spindle Drives

Order Number: 6SN1197-0AA00-0□P□

SIMODRIVE 611 Planning Guide

AC Motors for Feed and Main Spindle Drives

Order Number: 6SN1197-0AA20-0□P□

SIMODRIVE 611 Analog System, Start-Up Guide

Transistor PWM Inverters for AC Feed Drives and AC Main Spindle Drives

Order Number: 6SN1197-0AA60-0□P□

SIMODRIVE 611 Planning Guide;

AC Induction Motors for Main Spindle Drives

Order No.: 6SN1197-0AC60-0□P□

SIMODRIVE 611 Planning Guide;

AC Motors for Main Spindle Drives

1FE1 Built-In Synchronous Motors

Order No.: 6SN1197-0AC00-0□P□

---



# Contents

<b>1</b>	<b>General Information</b> .....	<b>1-13</b>
<b>2</b>	<b>Description of Components and Order Numbers</b> .....	<b>2-15</b>
2.1	Sensor head .....	2-15
2.2	Sensor wheel .....	2-15
2.3	Cable module .....	2-16
<b>3</b>	<b>Technical Data</b> .....	<b>3-17</b>
<b>4</b>	<b>Installation/Calibration</b> .....	<b>4-21</b>
4.1	Mounting the sensor wheel .....	4-22
4.2	Mounting/adjusting the sensor head .....	4-23
4.3	Mounting the cable assembly .....	4-24
<b>5</b>	<b>Assembly Drawings</b> .....	<b>5-25</b>
5.1	Dimension sheet .....	5-26
5.2	Dimension date and tolerances .....	5-27
5.3	Mounting drawing .....	5-28



# General Information

# 1

## Scope of application

SIMAG H is an incremental measuring (encoder) system for sensing angles of rotation and angular velocity.

The system is designed for hollow-shaft applications with 1FE1 and 1PH2 direct drives, but is also capable of operating as an autonomous spindle encoder.

SIMAG H can be used with the following SIEMENS drive systems:

- SIMODRIVE 611 digital
- SIMODRIVE 611 analog (in this case, only in conjunction with the measuring wheel, pole number  $2^n$ )
- MASTERDRIVES

## Design

The SIMAG H measuring system consists of three components.

- Sensor wheel
- Sensor head with attached gauge holder plus  
1 feeler gauge (0.20 mm) and  
1 3x12 cylindrical pin
- Fully pre-assembled cable module with  
4 M 2.5x8 screws for mounting the flange-mounted socket and  
2 M 3x6 screws for attaching the connector to the sensor head

The sensor wheel carries a magnetic pitch as a fixed gauge. Various different inside diameters are available for each outside diameter. The inside diameter can be re-machined later if required.

The sensor wheel is attached by means of the shaft nut or, alternatively, screwed to a shaft collar (not suitable for all sensor wheel variants).

The sensor head scans the incremental and reference tracks on the sensor wheel by a non-tactile method and amplifies the output signals.

The standard signal cables are connected via the flange-mounted socket on the cable module. This is fully pre-assembled and attachable to the sensor head. In this way, the measuring system can be optimally adapted to the prevailing installation conditions.

Installation and mounting drawing 5-2.  
Dimension drawing, refer to 5-1.

---

**Notice**

SIMAG H is a measuring instrument.

The encoder system must always be installed by a qualified person.

Any type of damage will impair the function of the instrument or render the system unserviceable.

Leave the encoder components in their packaging until you are ready to install them!

Please apply ESDS protection measures (refer to the Foreword).

Disconnect the power supply before commencing with the installation.

No liability will be accepted for any damage caused by improper handling of components.

---

**Output signals**

After installation and calibration, the measuring system supplies

- two sinusoidal incremental signals of 1 Vpp in quadrature
  - one square-wave reference signal per revolution
- 

**Note**

SIMAG H is compatible with SIMODRIVE motor measuring systems in terms of electrical signals and signal connector.

The SIMAG H measuring system is scheduled to supersede the SIZAG 2 gearwheel encoder in the medium term and should therefore be considered for new spindle unit designs.

---

**Connection**

Pre-assembled signal leads are available for connecting the sensor to SIMODRIVE converters.

See Catalog NC-Z and NC 60 for ordering information.



# Description of Components and Order Numbers

# 2

## 2.1 Sensor head

- Compact sensor head for mounting on bearing endshield of motor or spindle
- Calibration via cylindrical pin and feeler gauge

Table 2-1 Order designation and pole pitch

Scanning head SIMAG H	
Order designation	6FX2001-6AA11-0AA0
Pole pitch	1 mm

## 2.2 Sensor wheel

- Plastic-coated ferrite rings with magnetic pitch on steel hub
- One pole ring each for incremental signals and zero signal
- Scale division of incremental track 1 mm
- Pole number (resolution) of the incremental track depends on the external diameter
- Various inside diameters available for each outside diameter (see Table 2-2)
- Mounting methods (see Section 4.1)
- The internal diameter can be machined, e.g. by turning it on a lathe

Table 2-2 Sensor wheel variants (for dimension assignments, see assembly drawing in Section 5)

Order numbers Sensor wheel	Number of increments	Outside diameter D1 [mm]	Inside diameter D3 [mm]	Weight approx. [kg]	Moment of in- ertia approx. [10 <sup>-4</sup> kgm <sup>2</sup> ]
6FX2001-6RB01-4DF0	256	81.14	35	0.5	5.3
6FX2001-6RB01-4EF0	256	81.14	45	0.4	4.6
6FX2001-6RB01-4GA5	256	81.14	60	0.2	2.8

## 2.3 Cable module

- Fully pre-assembled
- Flange-mounted socket at converter end, straight or angled, for connection of signal cable
- Plug-in connection at encoder end:  
Axial mounting direction, tangential cable exit direction
- Connecting cable for temperature sensor

Table 2-3 Variants of cable module (for dimension assignments, see assembly drawing in Section 5)

Order numbers Cable module	Length of signal cable L1 [m]	Length of temperature sensor lead L2 [m]	Flange-mounted socket
6FX2001-6KA10-1CA0	0.2+0.01	0.3 ±0.01	angled
6FX2001-6KA10-1DA0	0.4+0.01	0.5 ±0.01	angled
6FX2001-6KA10-1EA0	0.6+0.01	0.7 ±0.01	angled
6FX2001-6KA10-1FA0	0.8+0.02	0.9 ±0.01	angled
6FX2001-6KA10-2AA0	1.0+0.01	1.1 ±0.02	angled
6FX2001-6KA10-2FA0	1.5+0.03	1.6 ±0.02	angled
6FX2001-6KA10-3AA0	2.0+0.02	2.1 ±0.02	angled
6FX2001-6KC10-1CA0	0.2+0.01	0.3 ±0.01	straight
6FX2001-6KC10-1DA0	0.4+0.01	0.5 ±0.01	straight
6FX2001-6KC10-1EA0	0.6+0.01	0.7 ±0.01	straight
6FX2001-6KC10-1FA0	0.8+0.02	0.9 ±0.01	straight
6FX2001-6KC10-2AA0	1.0+0.01	1.1 ±0.02	straight
6FX2001-6KC10-2FA0	1.5+0.03	1.6 ±0.02	straight
6FX2001-6KC10-3AA0	2.0+0.02	2.1 ±0.02	straight





## 3

## Technical Data

Table 3-1 Encoder tolerances (at the measuring system outputs for 120 Ω termination)

Features	Description/technical data
Indexing accuracy of sensor wheel	Pole pitch 1mm: "72" with pole number of 256
Storage temperature	-20 °C...+70 °C (in packaging)
Operating temperature	-20 °C...+100 °C
Degree of protection	IP65 to DIN 40050 (with connector mounted on and screwed to sensor head enclosure)
Permissible bending radius	Cable module connecting cable: once min. 25 mm several times min. 60mm
Permissible cable length	Max. 50m depending on closed-loop control used (see Catalog NC-Z for recommended cables)
Vibration resistance (50...2000Hz)	Max. 200 m/s <sup>2</sup>
Shock resistance (11ms)	Max. 1000 m/s <sup>2</sup>
Sensor wheel / sensor head assignment	Permissible axial tolerance: "1mm referred to nominal size (see Section 5.1 for nominal size). Must be maintained under all operating conditions (temperature, vibration, etc.)
Nominal clearance between sensor wheel / head	Pole pitch 1mm: 0.2 mm (adjustable with feeler gauge)
Permissible maximum speed	6FX2001-6RB01-4□□0: 24000 RPM
Voltage supply	U <sub>GB</sub> = 5V " 5%
Power consumption (typical)	40mA (typical)
Output signals	Sinusoidal 1V <sub>pp</sub> with 120Ω termination of signal cable
Miscellaneous	The components of the measuring system are resistant to all commercially available coolants and lubricants.

**Eccentricity-related error**

Additional error in mounted state:

$$\pm |\Delta\varphi| [^\circ] = \pm 1296 \frac{\text{Eccentricity}^1) [\mu\text{m}]}{\text{Pole number} * \text{pole pitch} [\text{mm}]}$$

1) Max. permissible eccentricity at room temperature: 20μm

Output signals

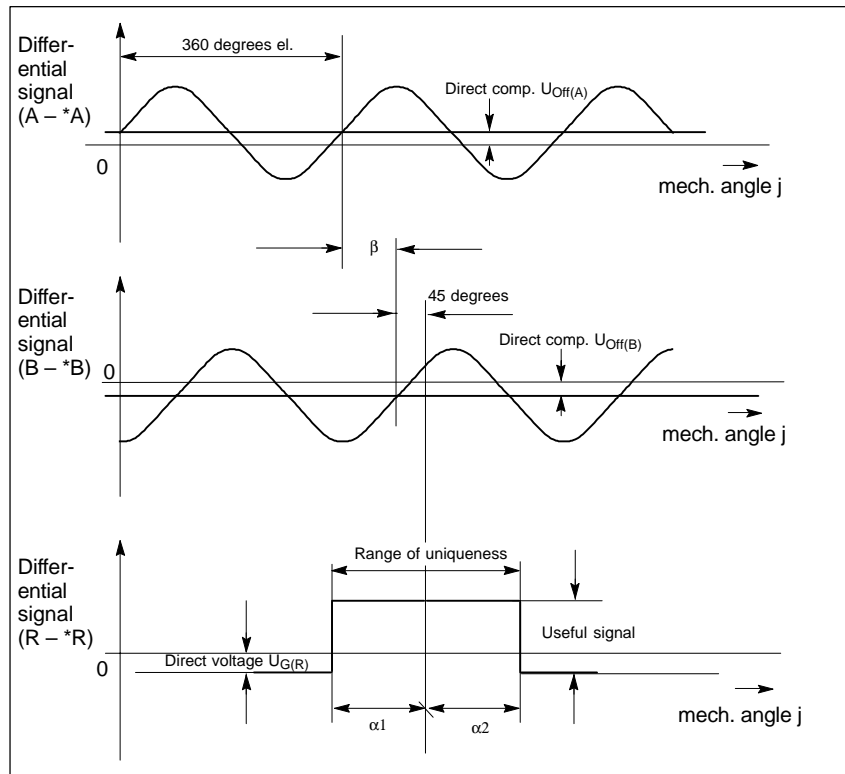

Fig. 3-1 Encoder signals with CW rotation

Table 3-2 Encoder tolerances (at measuring system outputs with 120W termination)

Parameter	Designation	Comment	min.	typ.	max.	Unit
Signal magnitude	A-*A; B-*B	$U_{GB} = 5 \text{ V}$ $f \leq 20 \text{ kHz}$	0.75	1	1.20	V <sub>PP</sub>
Ratio	(A-*A)/(B-*B)		0.9	1.0	1.1	-
Direct component (offset)	$U_{OFF(A)}/(A-*A)$ ; $U_{OFF(B)}/(B-*B)$		-15	0	+15	mV
Phase angle	$\beta$		89	90	91	Degrees
Useful signal	R-R*		0.4	-	1.2	V
Quiescent value $U_{G(R)}/\text{useful value}$	$U_{G(R)}/(R-R^*)$		30	50	70	%
Range of uniqueness	$\alpha_1$ ; $\alpha_2$		90	180	270	Degrees

**Connector pin assignments**

Flange-mounted socket, view of pin side:

PIN No.	Core color	Signal
1	green	A
2	yellow	*A
3	grey	R +
4		not connected
5		not connected
6		not connected
7	white	M encoder
8	brown	+Temp <sup>1)</sup>
9	white	-Temp <sup>1)</sup>
10	brown	P encoder
11	blue	B +
12	red	*B
13	pink	*R
14		not connected
15	black	0 V sense
16	violet	5 V sense
17		not connected

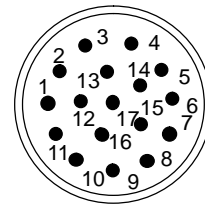

View of mating side (pins)

<sup>1)</sup>: 2-core temperature sensor cable





# Installation/Calibration

# 4

The encoder system is installed in three steps

- The sensor wheel is mounted on spindle shaft (see Section 4.1)
- The sensor head is mounted and calibrated (see Section 4.2)
- The cable assembly is mounted (refer to Section 4.3)

## General information

All dimensions, tolerances and designations specified in this section refer to the assembly drawing (see Section 5.1).

---

### Notice

SIMAG H is a measuring instrument.

The encoder system must always be installed by a qualified person.

Any type of damage will impair the function of the instrument or render the system unserviceable.

Leave the encoder components in their packaging until you are ready to install them!

Please apply ESDS protection measures (refer to the Foreword).

Disconnect the power supply before commencing with the installation.

No liability will be accepted for any damage caused by improper handling of components.

---

## Mounting space of the measuring system

---

### Caution

The mounting space of the measuring system must be kept free of metal chips, dust and other debris.

It must be guaranteed that no solid parts can get lodged between the sensor wheel and sensor head. Otherwise, the sensor wheel and/or sensor head could be damaged.

The measuring system, when required, must be appropriately covered

---

## External fields

Current flowing through motor windings and power cables can generate magnetic fields.

In order to avoid this influencing the measuring precision of the encoder system, a minimum clearance of 10 mm must be maintained on all sides between the motor windings/power cables and sensor head.

## 4.1 Mounting the sensor wheel

### Note

The eccentricity of the installed sensor wheel affects the accuracy of the whole system (see Section 3).

Do not allow permanent magnets, magnetic mounts for clock gauges, etc. to come into contact with the sensor wheel!

### Tolerances, motor shaft

Permissible radial eccentricity and axial eccentricity tolerances as well as position tolerances of the drilled holes, refer to Section 5.1.

### Installation methods

The sensor wheel can be attached to the shaft by the following methods:

1. Shrink fit
2. Axial screw mounting
3. Axial clamping

For information/instructions on this, refer to Table 4-1.

Table 4-1 Mounting types, designation of the diameter, refer to Section 5.1

Application	Diameters D3, D4, D5	Information
Shrink fit (mounting type)	D3/D5 press fit, e.g. H6 / r6 or H6 / s6	<ul style="list-style-type: none"> <li>• Inductive heating is not permissible to inductively heat-up</li> <li>• Max. sensor wheel temperature, 120° C</li> </ul>
Screw connection (mounting type)	D4 Material weakening above D4 not permissible	<ul style="list-style-type: none"> <li>• Mounting holes/withdrawal threads must be provided by the customer</li> <li>• Screws and washers are not included in the scope of supply</li> <li>• Note the tightening torque (refer to Fig. 5-2)</li> </ul>
Shaft nut (mounting type)	—	<ul style="list-style-type: none"> <li>• The shaft nut is not included in the scope of supply</li> <li>• Tightening torque: <math>M_D = f(F_{clamping})</math>, <math>F_{clamping} = 20 \text{ kN}</math> acc. to the manufacturer's data</li> </ul>
D3 screw on	D—customer Material weakening above D4 not permissible	<ul style="list-style-type: none"> <li>• Locate over D2 with pliers</li> <li>• Maintain the radial eccentricity of 0.02 mm from D3 to D1</li> </ul>
Clearance fit	D3/D5 Max. permissible play: +0.03 mm	—

## 4.2 Mounting/adjusting the sensor head

---

### Important

SIMAG H is a measuring instrument.

The sensor head must be screwed to the grounded metal assembly through a good electrical connection.

The sensor head is adjusted using the feeler gauge provided.

It is neither permissible nor is it necessary to make an adjustment using the encoder signals.

The specified degree of protection of the encoder system is only guaranteed when the encoder connector is screwed into place.

Before and during mounting, all parts and mounting surfaces must be free of any accumulated dirt.

The tightening torques must be carefully maintained (refer to Fig. 5-2).

---

### Mounting steps

Numbers in brackets, refer to the positions in Fig.5-2.

1. Insert the cylindrical pin (4) in the alignment bore of the bearing endshield (10).
2. Position the sensor head (2) over the cylindrical pin and very carefully press-in.
3. Insert the feeler gauge (5) into the gauge holder (3) of the sensor head; swivel the sensor head onto the sensor wheel.
4. Insert two screws (6) (M4, minimum length 12 mm) with two washers (7) in the threaded holes of the bearing end shield and slightly tighten.
5. Gently press the sensor head (2) against the feeler gauge and sensor wheel, tighten the retaining screws (6). Secure the screws so that they cannot be released.
6. Remove the feeler gauge (5) from the holder; the feeler gauge must be able to be easily withdrawn, however with slight suction, but without resistance.
7. Check the seating and state of the O ring seal in the connector (8) of the cable assembly on the encoder side.
8. Remove the gauge holder (3), insert the connector of the cable assembly (8) and tighten using the two M3x6 screws (9).

## 4.3 Mounting the cable assembly

---

### Important

The flange-mounted socket must be screwed to an earthed metal object to make a conductive connection. Remove any paint/varnish on mounting surface.

To ensure fault-free operation, do not open the pre-assembled cable ends.

---

Dimensions of the flange-mounted socket and mounting holes, refer to Fig. 5-1.

### EMC Guidelines

Observe the general guidelines for correctly routing cables regarding EMC.

### Mounting steps

Prerequisite: The sensor wheel and sensor head have been mounted.

1. Thread the connector of the cable assembly, on the encoder side, as well as the connecting cable for the motor temperature sensor through the mounting hole of the flange-mounted socket.
2. Insert the flange-mounted socket in the mounting hole and retain using the 4 M 2.5 screws provided (tightening torque, refer to Fig. 5-2).
3. Route the signal cable to the mounting location of the sensor head and retain using the 2 M3x6 screws provided (tightening torque, refer to Fig. 5-2).
4. Route the temperature sensor cable to the connecting terminal of the motor temperature sensor; if required, shorten and connect to the motor temperature sensor.

**The polarity must be carefully observed when connecting the temperature sensor cable!** Refer to the Product Documentation of the motor manufacturer.

The color of the cores and polarity of the cable: Refer to the connection assignment, flange-mounted socket, Section 3.

### Cable routing

The following must be observed when routing signal and temperature encoder cables:

- Route the cables so that they are not under tension
  - Do not route cables over sharp edges
  - Keep cables away from rotating parts and components
  - Securely retain in place
  - Carefully observe the permissible bending radii (refer to Section 3).
- 



# Assembly Drawings

# 5

### 5.1 Dimension sheet

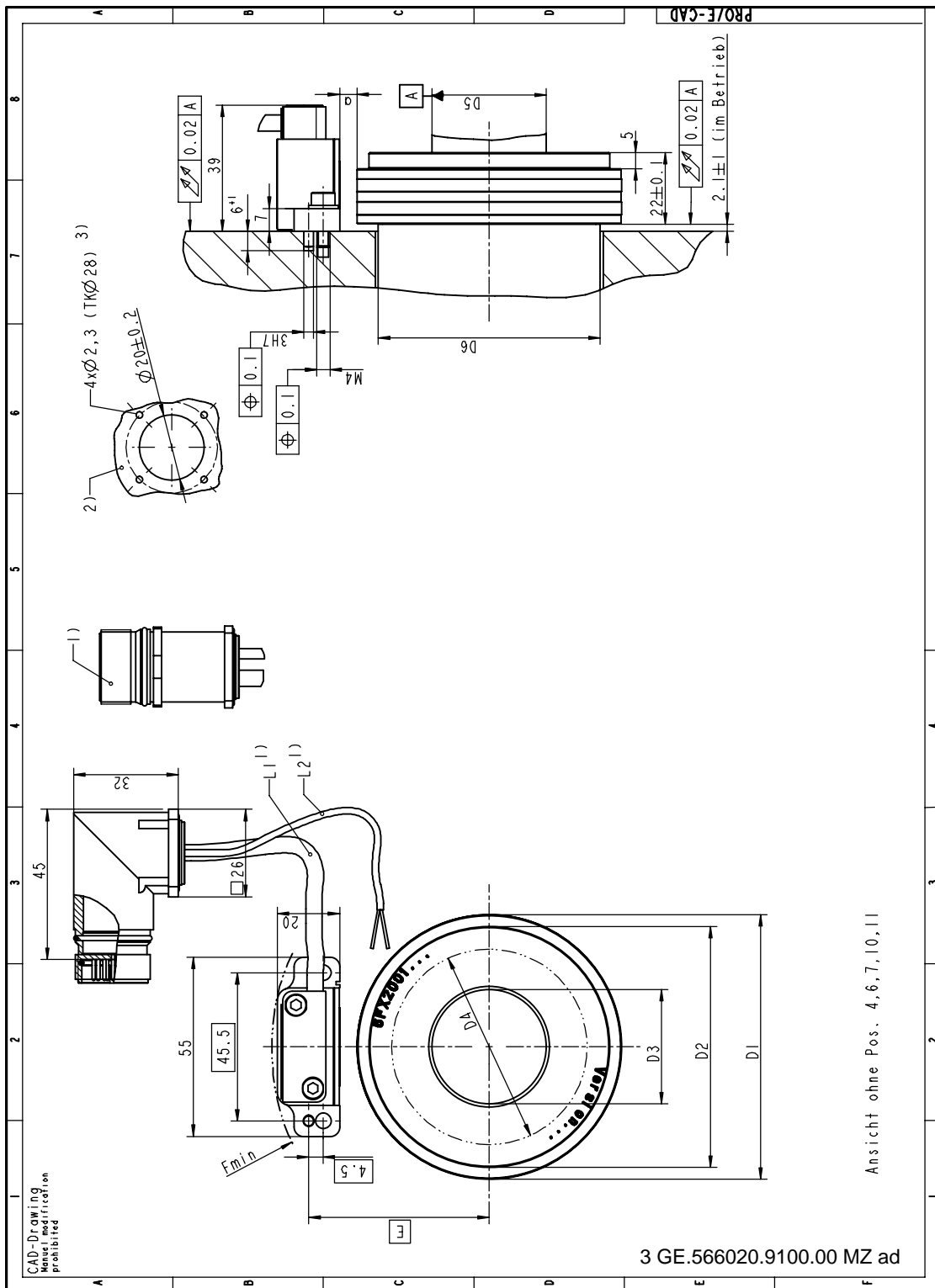

Fig. 5-1 Dimension sheet

- 1) Versions of the flange-mounted socket and cable lengths, refer to Section 2
- 2) Mounting hole, flanged-mounted socket
- 3) Hole depth 12mm

## 5.2 Dimension date and tolerances

Table 5-1 Versions of the sensor wheel (assignment of the dimensions, refer to Fig. 5-1)

Ordering No. Sensor wheel 6FX2001-	Number of incre- ments	D1 [mm]	D2 [mm]	D3 [mm]	D4 [mm]	D6 <sub>min</sub> [mm]	D6 <sub>max</sub> [mm]	E [mm]	F <sub>min</sub> [mm]	a [mm]
-6RB01-4DF0	256	81.14 -0.05	73.9 ±0.02	35 H6	60	41	80	50.4	125/2	0.2
-6RB01-4EF0	256	81.14 -0.05	73.9 ±0.02	45 H6	60	51	80	50.4	125/2	0.2
-6RB01-4GA5	256	81.14 -0.05	73.9 ±0.02	60 H6	60	66	80	50.4	125/2	0.2

### Explanation of the abbreviations

D1	Outer diameter, sensor wheel
D2	Tensioning collar, sensor wheel
D3	Inner diameter, sensor wheel
D4	Material weakening permissible up to D4
D5	Shaft diameter
D6 <sub>min</sub>	Min. diameter, shaft collar
D6 <sub>max</sub>	Max. diameter, shaft collar
E	Distance between the shaft center and centering pin
F <sub>min</sub>	Min. radius for the encoder mounting space
a	Clearance between the sensor head and sensor wheel (adjusted using the feeler gauge)

### 5.3 Mounting drawing

Position	Quantity	Designation	Item No. / Standard	Tightening torque	Scope of supply
1	1	Sensor wheel	Refer to Table 2-2	—	yes
2	1	Sensor head	Refer to Table 2-1	—	yes
3	1	Gauge holder	—	—	yes
4	1	Cylindrical pin	ISO 2338-A-3x12-St	—	yes
5	1	Feeler gauge	0.20 mm	—	yes
6	2	Cylindrical screw	DIN 912-M4x12-8.8	1.8 Nm	no
7	2	Washer	DIN 125-A4.3-140HV-St	—	no
8	1	Cable assembly	Refer to Table 2-3	—	yes
9	2	Cylindrical screw	DIN 912-M3x6-8.8	0.8 Nm	yes
10	—	Bearing endshield	—	—	—
11	—	Shaft collar	—	—	—
12	4	Screw	Special screw, M2.5x8	0.4 Nm	yes

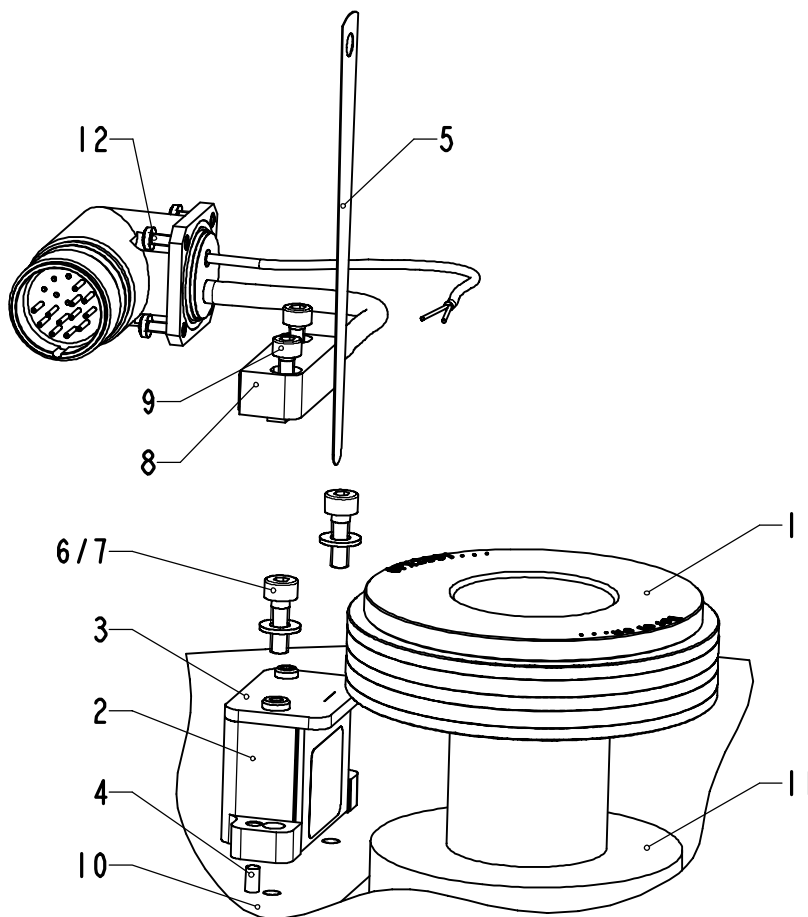

Fig. 5-2 Mounting drawing

SIEMENS AG  
A&D MC BMS  
P.O. Box 3180

D-91050 Erlangen  
Federal Republic of Germany

Tel.: +49 - 180 / 5050 - 222 [ServiceSupport]  
Fax: +49 - 9131 / 98 -2176 [Documentation]  
email: motioncontrol.docu@erlf.siemens.de

**Suggestions**

**Corrections**

For Publication/Manual:

SIMODRIVE sensor – SIMAG H  
Measuring System for  
Main Spindle Drives

**From**

Name

Company/Dept.

Street

Postal code:           Address

Telephone:                 /

Telefax:                    /

**Installation Guide**

Order No.:           6SN1197-0AB30-0BP1  
Edition:              07.2002

Should you come across any printing errors  
when reading this publication, please notify us  
on this sheet.

Suggestions for improvement are also welcome.

**Suggestions and/or corrections**



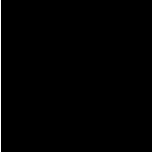

**Siemens AG**

Automatisierungs- und Antriebstechnik

Motion Control Systems

Postfach 3180, D – 91050 Erlangen

Bundesrepublik Deutschland

[www.ad.siemens.de](http://www.ad.siemens.de)

© Siemens AG 2002  
Subject to change without prior notice  
Order no.: 6SN1197-0AB30-0BP1  
Printed in the Federal Republic of Germany