

MEDIUM POWER LINEAR AND SWITCHING APPLICATIONS

- Complement to BD433, BD435 and BD437 respectively

ABSOLUTE MAXIMUM RATINGS

Characteristic	Symbol	Rating	Unit
Collector Base Voltage : BD434	V_{CBO}	- 22	V
: BD436		- 32	V
: BD438		- 45	V
Collector Emitter Voltage : BD434	V_{CES}	- 22	V
: BD436		- 32	V
: BD438		- 45	V
Collector Emitter Voltage : BD434	V_{CEO}	- 22	V
: BD436		- 32	V
: BD438		- 45	V
Emitter Base Voltage	V_{EBO}	- 5	V
Collector Current (DC)	I_C	- 4	A
Collector Current (Pulse)	I_C	- 7	A
Base Current	I_B	- 1	A
Collector Dissipation ($T_C=25^\circ\text{C}$)	P_C	36	W
Junction Temperature	T_J	150	$^\circ\text{C}$
Storage Temperature	T_{STG}	-65 ~ 150	$^\circ\text{C}$

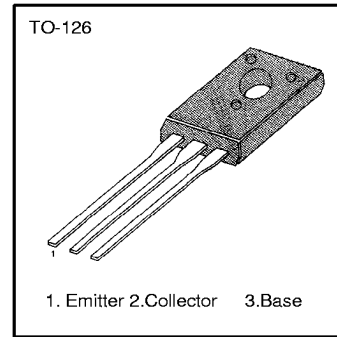

ELECTRICAL CHARACTERISTICS ($T_C=25^\circ\text{C}$)

Characteristic	Symbol	Test Condition	Min	Typ	Max	Unit	
Collector Emitter Sustaining Voltage : BD434	$V_{CEO(SUS)}$	$I_C = -100\text{mA}, I_B = 0$	- 22			V	
: BD436			- 32			V	
: BD438			- 45			V	
Collector Cutoff Current : BD434	I_{CBO}	$V_{CB} = -22\text{V}, I_E = 0$			- 100	μA	
: BD436			$V_{CB} = -32\text{V}, I_E = 0$			- 100	μA
: BD438			$V_{CB} = -45\text{V}, I_E = 0$			- 100	μA
Collector Cutoff Current : BD434	I_{CEO}	$V_{CE} = -22\text{V}, V_{BE} = 0$			- 100	μA	
: BD436			$V_{CE} = -32\text{V}, V_{BE} = 0$			- 100	μA
: BD438			$V_{CE} = -45\text{V}, V_{BE} = 0$			- 100	μA
Emitter Cutoff Current	I_{EBO}	$V_{EB} = -5\text{V}, I_C = 0$			- 1	mA	
*DC Current Gain : BD434/436	h_{FE}	$V_{CE} = -5\text{V}, I_C = -10\text{mA}$	40	140			
: BD438			30	140			
: ALL DEVICE			$V_{CE} = -1\text{V}, I_C = -500\text{mA}$	85	140		
: BD434/436			$V_{CE} = -1\text{V}, I_C = -2\text{A}$	50			
: BD438				40			
* Collector Emitter Saturation Voltage : BD434	$V_{CE(sat)}$	$I_C = -2\text{A}, I_B = -0.2\text{A}$		- 0.2	- 0.5	V	
: BD436				- 0.2	- 0.5	V	
: BD438				- 0.2	- 0.6	V	
*Base Emitter On Voltage : BD434	$V_{BE(on)}$	$V_{CE} = -1\text{V}, I_C = -2\text{A}$			- 1.1	V	
: BD436					- 1.1	V	
: BD438					- 1.2	V	
Transition Frequency	f_T	$V_{CE} = -1\text{V}, I_C = -250\text{mA}$	3			MHz	

*Pulse Test: PW=300 μs , duty Cycle=1.5% Pulsed

