

MODEL NO.	FREQ. MHz		GAIN, dB Typical (at MHz)					MAXIMUM POWER, dBm		DYNAMIC RANGE		VSWR Typ.		MAXIMUM RATING (25°C)		DC POWER at Pin 3		CAPD DATA	Case Style	FUNCTION	Price \$ (QTY25)
	f _L	f _H	100	500	1000	2000	MIN.	Typ Output (1dB Comp)	Input (no damage)	NF dB Typ.	IP3 dBm Typ.	In	Out	I(mA)	P(mW)	Current mA	Volt Typ.	(see RF/IF Designer Handbook)	Note B		
□ MAV-1	DC-1000		18.5	17.0	15.0	—	12.5	+1.5	+13	5.5	+14.0	1.4:1	1.3:1	40	200	17	5.00	3-24	BBB123	cb	1.10
□ MAV-2	DC-1500		12.5	12.0	11.0	10.0*	7.5	+4.5	+13	6.5	+17.0	1.3:1	1.4:1	60	325	25	5.00	3-24	BBB123	cb	1.40
□ MAV-3	DC-1500		12.5	12.0	11.0	10.0*	7.5	+10.0	+13	6.0	+23.0	1.3	1.1:6:1	70	400	35	5.00	3-25	BBB123	cb	1.50
□ MAV-4	DC-1000		8.3	8.0	7.5	—	7.0	+11.5	+13	7.0	+24.5	1.4:1	1.8:1	85	500	50	5.25	3-25	BBB123	cb	1.60
□ MAV-11	DC-1000		12.7	12.0	10.5	—	9.0	+17.5	+13	3.6	+30.0	1.5:1	1.7:1	80	550	60	5.50	3-25	BBB123	cb	2.10
● VAM-3	DC-2000		11.5	11.5	11.0	9.5	7.5	+9.0	+13	6.0	+22.0	1.5:1	1.7:1	60	240	35	4.70	3-26	MMM168	cb	1.45
● VAM-6	DC-2000		19.5	18.0	15.0	10.0	8.0	+2.0	+13	3.0	+14.0	1.6:1	1.5:1	40	125	16	3.30	3-26	MMM168	cb	1.29
● VAM-7	DC-2000		13.0	12.6	12.0	9.8	7.8	+5.5	+13	5.0	+18.0	1.5:1	1.5:1	50	175	22	3.80	3-26	MMM168	cb	1.75
● VNA-25	500-2500		—	14.0	18.0	16.0	11.5	+18.2	+10	5.5	+27.0	1.5:1	1.6:1	7*	1000	85	5.0	—	XX211	hj	4.25

features

- cascadable
- excellent repeatability
- wide bandwidth DC-2000 MHz; VNA 500 - 2500 MHz
- unconditionally stable, except MAR-6, MAR-6SM, RAM-6, VAM-6, MAR-8, MAR-8SM, RAM-8

- low cost, MAR, MAV, VAM models
- hermetically sealed, RAM models
- low noise figure, 2.8 to 3.6 dB typ., MAR-6, MAR-8, MAV-11, RAM-6, RAM-8, VAM-6
- high output power, +17 dBm typ., MAV-11 +18 dBm typ., VNA-25

NSN GUIDE

MCL NO.	NSN
MAR-3	5962-01-339-2933
MAR-8	5998-01-360-6957
MAV-11	5998-01-360-6958

pin connections

PORT	cb	hj
RF IN	1	3
RF OUT	3	6
DC	3	1
CASE GND	2,4	2,4,5,7,8
NOT USED	—	—

Biasing Configuration VNA

V SUPPLY

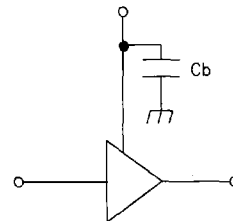

Typical Biasing Configuration MAV/VAM

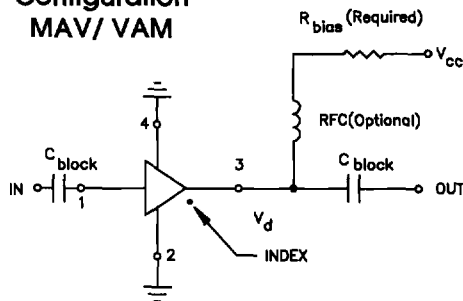

REFLOW - SOLDERING PROFILE

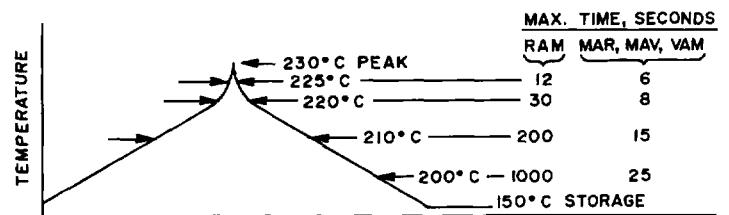

In Stock...Immediate Delivery

For custom versions of standard models consult our applications dept.