

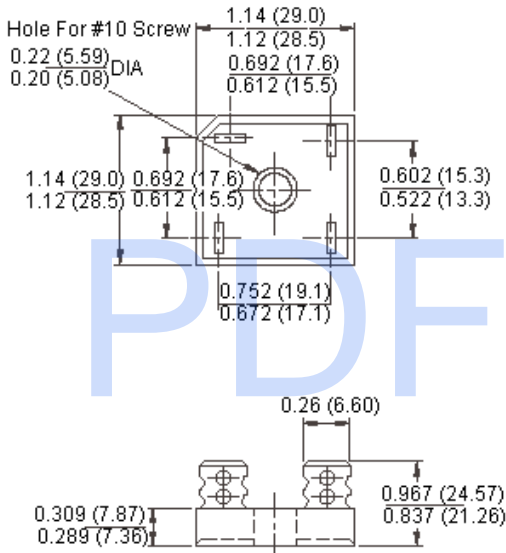

Features:

- Plastic material.
- Integrally moulded heatsink provide very low thermal resistance for maximum heat dissipation.
- Surge overload ratings from 300 to 400 amperes.
- Terminals solderable per MIL-STD-202, method 208 (for wire type).
- Typical I_R less than $0.2\mu A$.
- High temperature soldering guaranteed, $260^\circ C/10$ seconds 0.375 inch ($9.5mm$) lead lengths (for wire type).
- Isolated voltage from case to lead over 2500 volts.

GBPC



GBPC-W

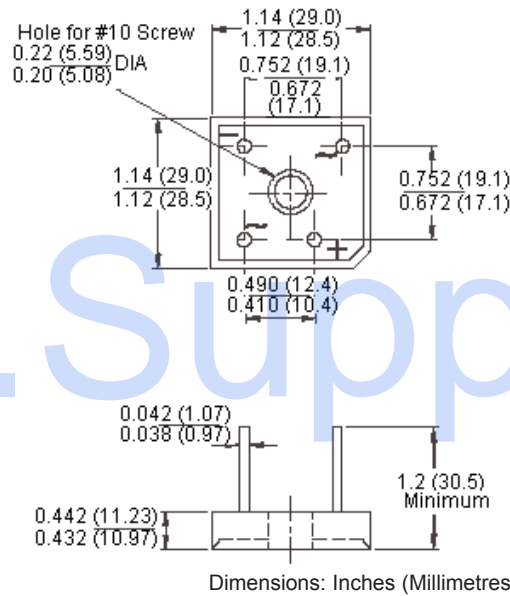

Maximum Ratings and Electrical Characteristics

Rating at 25°C ambient temperature unless otherwise specified.

Single phase, half wave, 60Hz, resistive or inductive load.

For capacitive load, derate current by 20%.

Type Number	Symbol	-005	-01	-02	-04	-06	-08	-10	Unit
Maximum Recurrent Peak Reverse Voltage	V_{RRM}	50	100	200	400	600	800	1000	V
Maximum RMS Voltage	V_{RMS}	35	70	140	280	420	560	700	
Maximum DC Blocking Voltage	V_{DC}	50	100	200	400	600	800	1000	
Maximum Average Forward Rectified Current at $T_C = 55^\circ\text{C}$	GBPC15 GBPC25 GBPC35 $I_{(AV)}$	15.0 25.0 35.0						A	
Peak Forward Surge Current, Single Sine-wave Superimposed on Rated Load (JEDEC method)	GBPC15 GBPC25 GBPC35 I_{FSM}	300 300 400						A	
Maximum Instantaneous Forward Voltage Drop Per Element at Specified Current	GBPC15 7.5A GBPC25 12.5A GBPC35 17.5A V_F	1.1						V	
Maximum DC Reverse Current at Rated DC Blocking Voltage Per Element	I_R	5						mW	
Typical Thermal Resistance (Note 1)	$R_{\theta JC}$	1.5						°C/W	
Operating and Storage Temperature Range	T_J, T_{STG}	-50 to +150						°C	

- Notes:**
1. Thermal Resistance from Junction to Case.
 2. Suffix "W" - Wire Lead Structure.

GBPC15,25,35- Series



Ratings and Characteristic Curves (GBPC15005 thru GBPC1510, GBPC25005 thru GBPC2510, GBPC35005 thru GBPC3510)

Maximum Forward Current Derating Curve

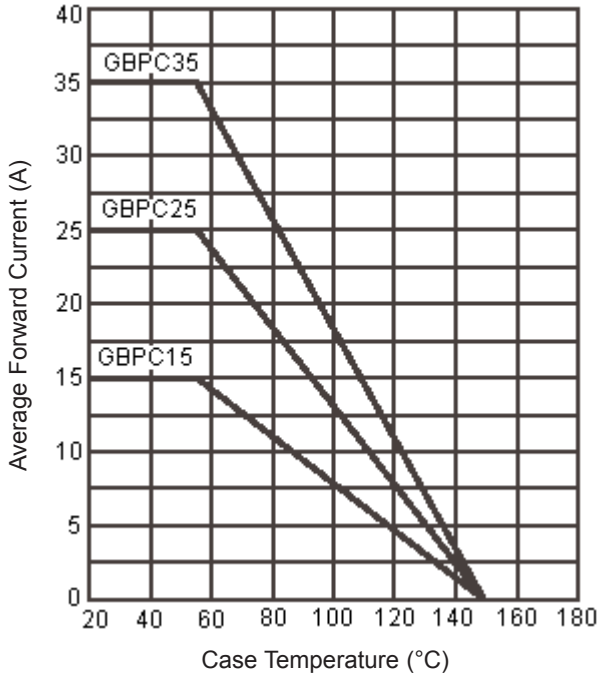

Typical Reverse Characteristics Per Bridge Element

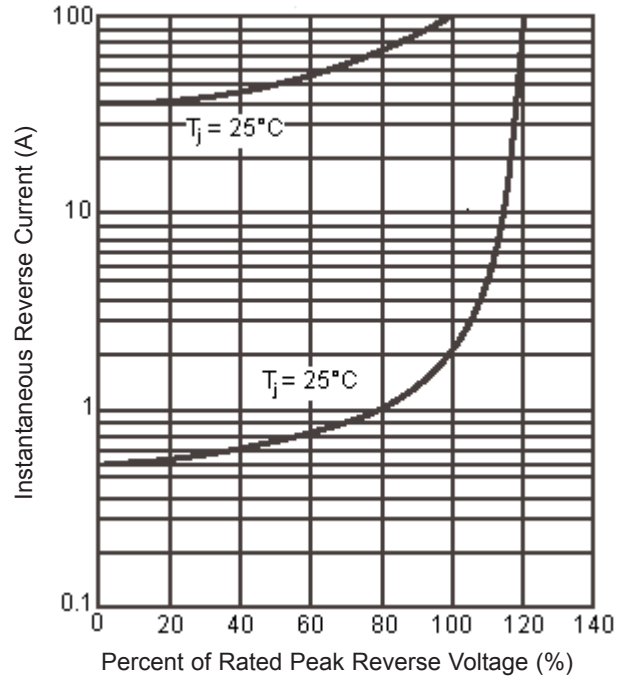

Maximum Non-Repetitive Forward Surge Current Per Bridge Element

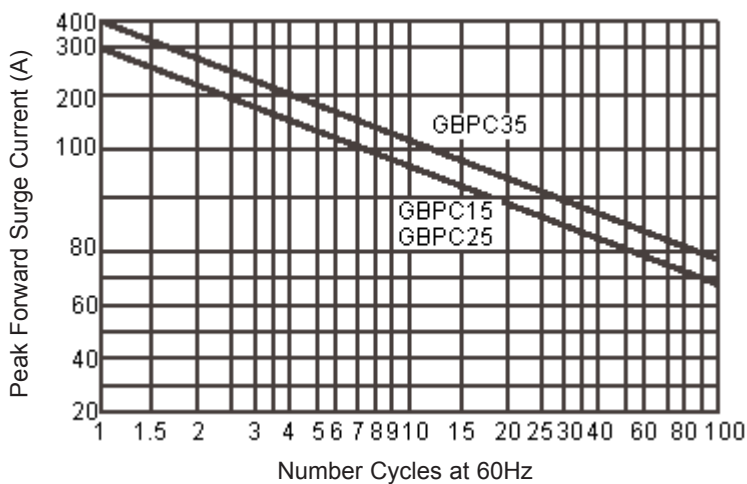

Typical Forward Characteristics Per Bridge Element

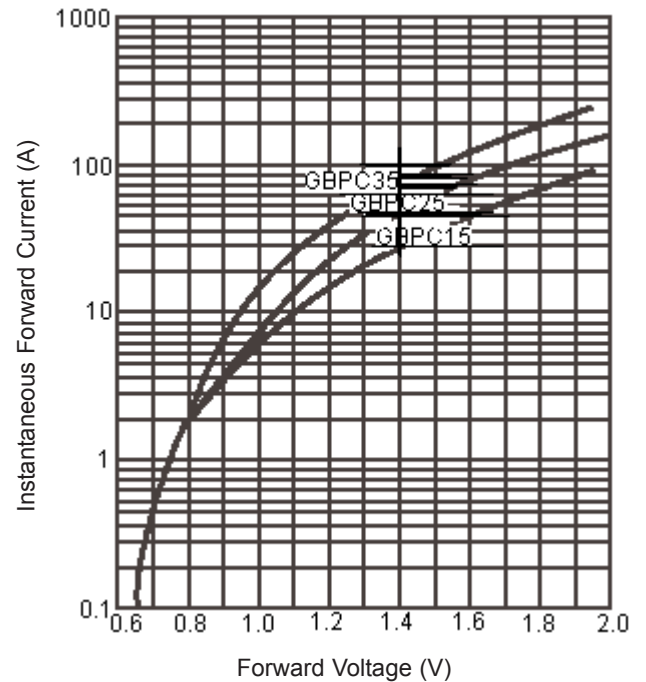

GBPC15,25,35- Series



Typical Junction Capacitance

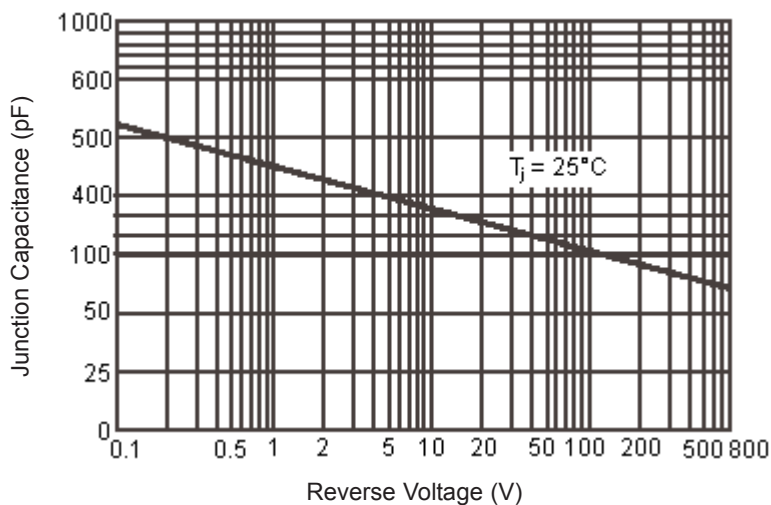

Part Number Table

Description	Part Number
Bridge Rectifier, 15A, 50V	GBPC15005
Bridge Rectifier, 15A, 50V	GBPC15005W
Bridge Rectifier, 15A, 100V	GBPC1501
Bridge Rectifier, 15A, 100V	GBPC1501W
Bridge Rectifier, 15A, 200V	GBPC1502
Bridge Rectifier, 15A, 200V	GBPC1502W
Bridge Rectifier, 15A, 400V	GBPC1504
Bridge Rectifier, 15A, 400V	GBPC1504W
Bridge Rectifier, 15A, 600V	GBPC1506
Bridge Rectifier, 15A, 600V	GBPC1506W
Bridge Rectifier, 15A, 800V	GBPC1508
Bridge Rectifier, 15A, 800V	GBPC1508W
Bridge Rectifier, 15A, 1000V	GBPC1510
Bridge Rectifier, 15A, 1000V	GBPC1510W
Bridge Rectifier, 25A, 50V	GBPC25005W
Bridge Rectifier, 25A, 100V	GBPC2501W
Bridge Rectifier, 25A, 200V	GBPC2502W
Bridge Rectifier, 25A, 400V	GBPC2504W
Bridge Rectifier, 25A, 600V	GBPC2506W
Bridge Rectifier, 25A, 800V	GBPC2508W



GBPC15,25,35- Series



Part Number Table

Description	Part Number
Bridge Rectifier, 25A, 1000V	GBPC2510
Bridge Rectifier, 25A, 1000V	GBPC2510W
Bridge Rectifier, 35A, 50V	GBPC35005B0
Bridge Rectifier, 35A, 50V	GBPC35005W
Bridge Rectifier, 35A, 100V	GBPC3501
Bridge Rectifier, 35A, 100V	GBPC3501W
Bridge Rectifier, 35A, 200V	GBPC3502W
Bridge Rectifier, 35A, 400V	GBPC3504
Bridge Rectifier, 35A, 400V	GBPC3504W
Bridge Rectifier, 35A, 600V	GBPC3506
Bridge Rectifier, 35A, 600V	GBPC3506W
Bridge Rectifier, 35A, 800V	GBPC3508
Bridge Rectifier, 35A, 800V	GBPC3508W
Bridge Rectifier, 35A, 1000V	GBPC3510
Bridge Rectifier, 35A, 1000V	GBPC3510W



Notes:

International Sales Offices:

	AUSTRALIA – Farnell Tel No: ++61 1300 361 005 Fax No: ++61 1300 361 225		FINLAND – Farnell Tel No: ++ 358 9 560 7780 Fax No: ++ 358 9 345 5411		ITALY – Farnell Tel No: ++ 39 02 93 995 200 Fax No: ++ 39 02 93 995 300		SPAIN – Farnell Tel No: 901 20 20 80 Fax No: 901 20 20 90
	AUSTRIA – Farnell Tel No: ++ 43 662 2180 680 Fax No: ++ 43 662 2180 670		FRANCE – Farnell Tel No: ++ 33 474 68 99 99 Fax No: ++ 33 474 68 99 90		MALAYSIA – Farnell-Newark Tel No: ++ 60 3 7873 8000 Fax No: ++ 60 3 7873 7000		SWEDEN – Farnell Tel No: ++ 46 8 730 50 00 Fax No: ++ 46 8 83 52 62
	BELGIUM – Farnell Tel No: ++ 32 3 475 2810 Fax No: ++ 32 3 227 3648		GERMANY – Farnell Tel No: ++ 49 89 61 39 39 39 Fax No: ++ 49 89 613 59 01		NETHERLANDS – Farnell Tel No: ++ 31 30 241 7373 Fax No: ++ 31 30 241 7333		SWITZERLAND – Farnell Tel No: ++ 44 204 64 64 Fax No: ++ 44 204 64 54
	BRAZIL – Farnell-Newark Tel No: ++ 55 11 4066 9400 Fax No: ++ 55 11 4066 9410		HONG KONG – Farnell-Newark Tel No: ++ 852 2268 9888 Fax No: ++ 852 2268 9899		NEW ZEALAND – Farnell Tel No: 0800 90 80 80 Fax No: 0800 90 80 81		UK – Farnell Tel No: ++ 44 8701 200 200 Fax No: ++ 44 8701 200 201
	CHINA – Farnell-Newark Tel No: ++86 10 6238 5152 Fax No: ++86 10 6238 5022		HUNGARY - Farnell Tel No: ++ 44 870 1200 208 Fax No: ++ 44 870 1200 209		NORWAY – Farnell Tel No: 800 146 70 Fax No: 800 146 76		UK – CPC ++ 44 8701 202 530 ++ 44 8701 202 531
	CZECH REPUBLIC - Farnell Tel No: ++ 44 870 1200 208 Fax No: ++ 44 870 1200 209		INDIA - Farnell Tel No: ++ 44 870 1200 208 Fax No: ++ 44 870 1200 209		PORTUGAL – Farnell Tel No: ++ 34 93 475 8804 Fax No: ++ 34 93 474 5288		USA – Newark Tel No: 800 463 9275
	DENMARK – Farnell Tel No: ++ 45 44 53 66 44 Fax No: ++ 45 44 53 66 06		IRELAND – Farnell Tel No: ++ 353 1 830 9277 Fax No: ++ 353 1 830 9016		RUSSIA – Farnell Tel No: ++ 44 870 1200 208 Fax No: ++ 44 870 1200 209	export EXPORT – Farnell Tel No: ++ 44 8701 200 208 Fax No: ++ 44 8701 200 209 For enquiries from all other markets	
	ESTONIA – Farnell Tel No: ++ 358 9 560 7780 Fax No: ++ 358 9 345 5411		ISRAEL – Farnell Tel No: ++ 180 937 0015 Fax No: ++ 180 937 0014		SINGAPORE – Farnell-Newark Tel No: ++ 65 6788 0200 Fax No: ++ 65 6788 0300	http://www.farnell.com http://www.newark.com http://www.cpc.co.uk	

Disclaimer This data sheet and its contents (the "Information") belong to the Premier Farnell Group (the "Group") or are licensed to it. No licence is granted for the use of it other than for information purposes in connection with the products to which it relates. No licence of any intellectual property rights is granted. The Information is subject to change without notice and replaces all data sheets previously supplied. The Information supplied is believed to be accurate but the Group assumes no responsibility for its accuracy or completeness, any error in or omission from it or for any use made of it. Users of this data sheet should check for themselves the Information and the suitability of the products for their purpose and not make any assumptions based on information included or omitted. Liability for loss or damage resulting from any reliance on the Information or use of it (including liability resulting from negligence or where the Group was aware of the possibility of such loss or damage arising) is excluded. This will not operate to limit or restrict the Group's liability for death or personal injury resulting from its negligence. SPC Multicomp is the registered trademark of the Group. © Premier Farnell plc 2008.