

Product Bulletin

# Bluetooth™ Chip Set Solution from Texas Instruments

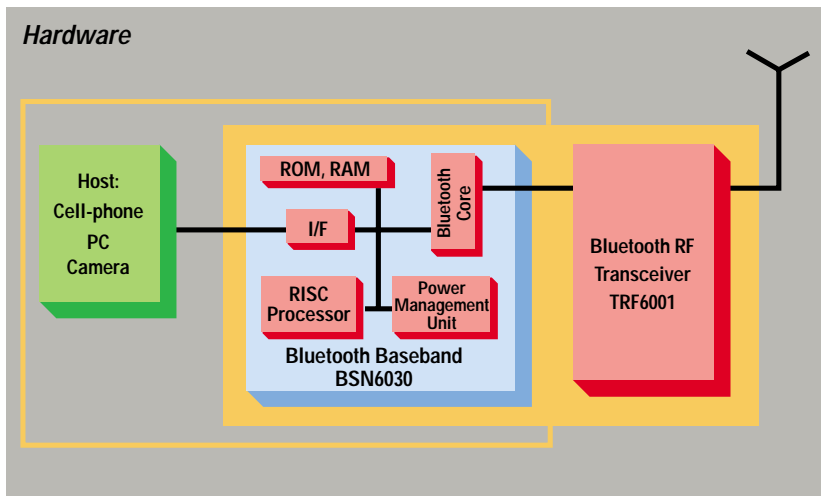

*TI's low-power, affordable Bluetooth Chip Set supports the latest Bluetooth specification with just two devices — an RF transceiver and a digital baseband controller. An all-digital interface between the devices, plus on-chip support for standard communication interfaces and TMS320™ digital signal processors (DSPs), make the chip set easy to implement in Bluetooth applications.*

The Bluetooth Chip Set from Texas Instruments provides a two-chip solution that supports the latest Bluetooth specification for short-distance wireless communications. Consisting of the BSN6030 Bluetooth Baseband Controller and the TRF6001 Bluetooth Radio Frequency (RF) Transceiver, the chip set integrates the complete Bluetooth software stack up to the Host Controller Interface (HCI), with no external flash memory required, for a complete Bluetooth system solution.

Operating in the 2.4-GigaHertz (GHz) ISM band worldwide, TI's Bluetooth solution supports simultaneous point-to-point transmission of voice and data, with rates up to 1 Megabit per second (Mbps). The chip set not only saves space and power but also can extend the range of transmission up to five times the distance of a standard implementation of the Bluetooth specification. Among the many types of systems that can take advantage of the TI solution are:

**Key Features:**

- Complete two-chip solution supports current Bluetooth™ specification
- Chip set includes:
  - Digital baseband controller with on-chip Bluetooth, ROM-based software stack up to Host Controller Interface (HCI)
  - RF transceiver
- No external flash memory required
- Extremely sensitive reception of -86 dBm extends range up to five times Bluetooth requirements
- Point-to-point support for simultaneous voice and data communication
- Supports up to 1 Mbps transmission in 2.4-GHz ISM band
- Low-power operation: around 10 mA for typical Bluetooth voice application
- All-digital interface between chips simplifies design
- Integrates easily with TMS320™ DSPs for use in mobile Internet appliances

- Digital cellular phones
- Internet appliances
- Cordless phones
- Hands-free phone headsets
- Wireless home networks for PCs, PDAs
- Remote game and video controls
- PC-peripheral communications, including printers, digital cameras, internet audio players

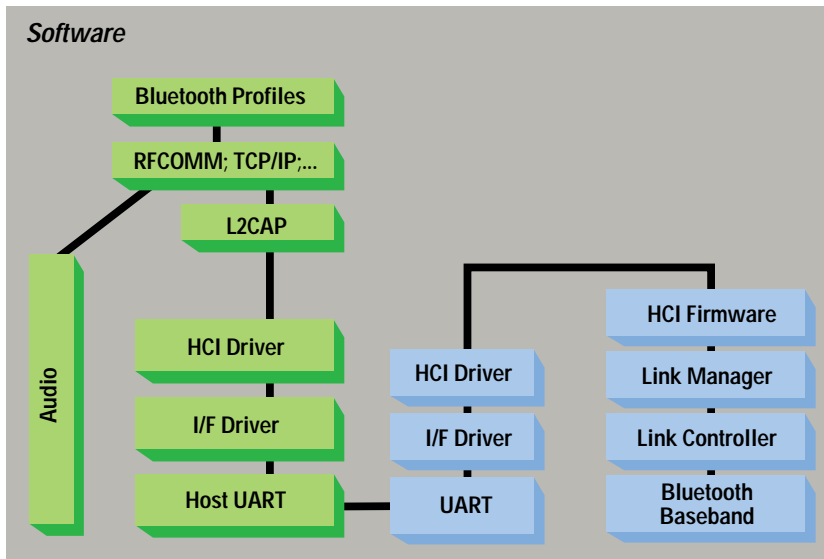

*TI's Bluetooth Chip Set includes the complete Bluetooth software stack up to the Host Controller Interface (HCI) in on-chip ROM, eliminating the need for external flash memory.*

**Extended Range**

The TI Bluetooth solution offers an extended sensitivity of -86 decibels with reference to 1 milliWatt (0 dBm) and a bit error rate (BER) of  $10^{-3}$ . This figure represents an increase of 16 dB beyond the sensitivity required by the standard. Under certain conditions, a signal that a basic implementation receives at no greater distance than 10 meters can be received by the TI solution

at up to 50 meters. This extra sensitivity allows applications using TI's Bluetooth solution to operate more reliably at longer distances.

**Low Power Consumption**

Both baseband controller and RF transceiver operate at 3.3 V and employ power-down modes to prolong system operation between battery charges. The BSN6030 controller features an extra-low-power 1.8-V core for

additional power savings. The high efficiency of the chip set keeps power consumption to about 10 milliamperes (mA) for a typical Bluetooth voice application.

**Worldwide Operation**

The TRF6001 transceiver employs frequency-hopping spread spectrum (FHSS) technology for maximum robustness of the radio link. The complete chipset is designed for worldwide regulatory compliance for operation in the 2.4-GHz frequency band.

**High Performance**

The BSN6030 controller achieves high performance with an integrated 32-bit ARM7™ RISC microprocessor, plus 16K words of RAM for data storage and 112K words of programmed ROM.

In addition to running the complete Bluetooth software stack up to the HCI, the device offers processing power for Bluetooth profiles or general application software. To save external components and simplify design, support for A-Law and  $\mu$ -Law codecs is included on chip, along with a high-speed UART serial interface.

**Flexible Clocking**

The chip set can operate with flexible clock sources ranging from 10 to 20 MHz in increments of 1 MHz. Since system clock requirements vary, this versatility permits designers to use TI's Bluetooth chip set in a wide variety of applications.

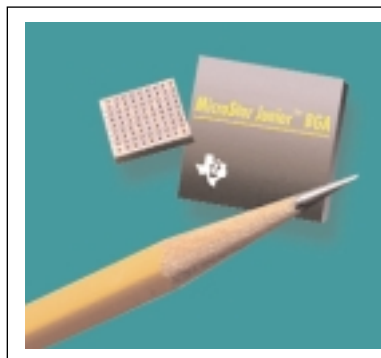

**MicroStar Junior™ Packaging**

TI's advanced MicroStar Junior packaging helps minimize your circuit board's size, weight and cost. These high-performance packages provide excellent heat dissipation and low inductance in a low-profile, chip-scale footprint. MicroStar Junior packages are available with fully or selectively populated ball grids.

### **Ease of Design**

An all-digital interface between the devices, plus several integrated interfaces to standard communications, make it easy to implement TI's Bluetooth solution in a system. The chip set also connects easily to a TMS320 DSP for added value in high-performance real-time applications such as mobile Internet appliances and wireless digital phones with Bluetooth capabilities.

The Bluetooth Chip Set is fully supported by an evaluation module (EVM), documentation and reference design, as well as by TI's extensive network of wireless applications specialists throughout the world.

### **Space Savings**

TI's Bluetooth chip set is designed to save space in mobile applications. No external flash memory is required for program code, saving cost and space, as well as

eliminating potential problems with the availability of flash devices.

The BSN6030 controller is available in a range of small-scale MicroStar Junior ball grid arrays (BGA), down to an 80-lead, 6x6 mm package. The TRF6001 transceiver is available in a 56-lead MicroStar Junior BGA that measures just 5x5 mm. Together, the chips require less board area than a single-chip 8x8 mm solution.

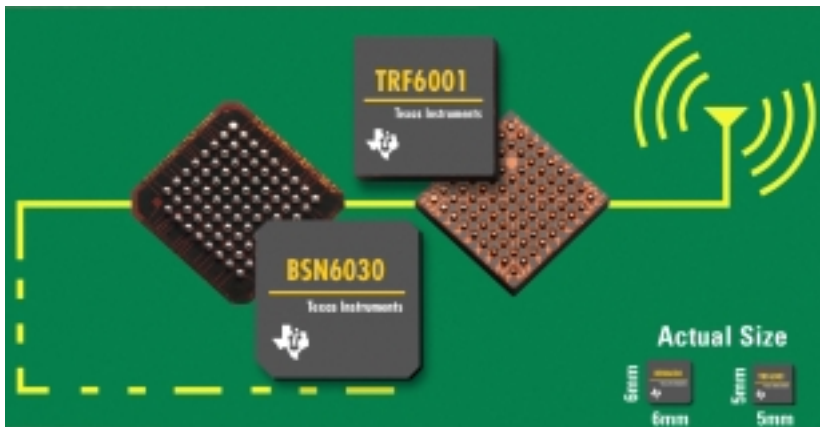

#### **BSN6030 Bluetooth Baseband Controller**

- Embedded ARM7 RISC microprocessor
- 16K word RAM, 112K word fully programmed ROM with Bluetooth software stack up to HCI including UART transport layer
- 3.3-V single supply with power-down modes
- Ultra-low-power 1.8-V core
- On-chip PLL for variable clock source from 10 to 20 MHz
- Integrated UART interface
- Glueless connection to external Codecs
- Space-saving MicroStar Junior BGA package options down to a 6x6 mm footprint

#### **TRF6001 Bluetooth RF Transceiver**

- 2.4-GHz frequency-hopping spread spectrum (FHSS) radio
- 3.3-V single supply with power-down mode
- -86 dB sensitivity at BER =  $10^{-3}$
- Single-conversion receiver
- Low-noise amplifier with gain control
- On-chip PLL for variable clock source from 10 to 20 MHz
- Space-saving 5x5 mm, 56-lead MicroStar Junior BGA package

### **TI's Roadmap for Bluetooth**

TI is committed to developing a complete family of low-power solutions for Bluetooth application needs. TI's plans for future generations of Bluetooth products include integration of functionality such as low intermediate frequency (IF) filtering, and support for point-to-multipoint operations.

### **For More Information**

To learn more about TI's Bluetooth Chip Set, or other TI short-distance wireless products, call your regional TI sales office or visit

[www.ti.com/sc/bluetooth](http://www.ti.com/sc/bluetooth)

# TI Worldwide Technical Support

---

## Internet

### TI Semiconductor Home Page

[www.ti.com/sc](http://www.ti.com/sc)

### TI Distributors

[www.ti.com/sc/docs/general/distrib.htm](http://www.ti.com/sc/docs/general/distrib.htm)

## Product Information Centers

### Americas

Phone +1(972) 644-5580  
Fax +1(214) 480-7800  
Internet [www.ti.com/sc/ampic](http://www.ti.com/sc/ampic)

### Europe, Middle East, and Africa

Phone  
Belgium (English) +32 (0) 27 45 55 32  
France +33 (0) 1 30 70 11 64  
Germany +49 (0) 8161 80 33 11  
Israel (English) 1800 949 0107  
Italy 800 79 11 37  
Netherlands (English) +31 (0) 546 87 95 45  
Spain +34 902 35 40 28  
Sweden (English) +46 (0) 8587 555 22  
United Kingdom +44 (0) 1604 66 33 99  
Fax +44 (0) 1604 66 33 34  
Email [epic@ti.com](mailto:epic@ti.com)  
Internet [www.ti.com/sc/epic](http://www.ti.com/sc/epic)

### Japan

Phone  
International +81-3-3344-5311  
Domestic 0120-81-0026  
Fax  
International +81-3-3344-5317  
Domestic 0120-81-0036  
Internet  
International [www.ti.com/sc/jpic](http://www.ti.com/sc/jpic)  
Domestic [www.tij.co.jp/pic](http://www.tij.co.jp/pic)

### Asia

Phone  
International +886-2-23786800  
Domestic Local Access Code TI Number  
Australia 1-800-881-011 -800-800-1450  
China 00-800-8800-6800 -  
Hong Kong 800-96-1111 -800-800-1450  
India 000-117 -800-800-1450  
Indonesia 001-801-10 -800-800-1450  
Korea 001-800-8800-6800 -  
Malaysia 1-800-800-011 -800-800-1450  
New Zealand 000-911 -800-800-1450  
Philippines 105-11 -800-800-1450  
Singapore 800-0111-111 -800-800-1450  
Taiwan 080-006800 -  
Thailand 0019-991-1111 -800-800-1450  
Fax 886-2-2378-6808  
Email [tiasia@ti.com](mailto:tiasia@ti.com)  
Internet [www.ti.com/sc/apic](http://www.ti.com/sc/apic)

**Important Notice:** The products and services of Texas Instruments and its subsidiaries described herein are sold subject to TI's standard terms and conditions of sale. Customers are advised to obtain the most current and complete information about TI products and services before placing orders. TI assumes no liability for applications assistance, customer's applications or product designs, software performance, or infringement of patents. The publication of information regarding any other company's products or services does not constitute TI's approval, warranty or endorsement thereof.

A050200

The red/black banner, TMS320 and MicroStar Junior are trademarks of Texas Instruments.  
Bluetooth is a trademark of Telefonaktiebolaget L M Ericsson.  
ARM is a trademark of Advanced RISC Machines, Ltd.  
All other trademarks are the property of their respective owners.

