

Mini-Com® TX6™ PLUS Shielded Jack Modules

PANDUIT®

SPECIFICATION SHEET

specifications

Category 6/Class E, 8-position, shielded jack module shall terminate 4-pair, 22 – 26 AWG, 100 ohm shielded twisted pair cable and shall not require use of a punchdown tool. Shielded jack modules shall use a forward motion termination method to optimize performance by maintaining cable pair geometry while eliminating conductor untwist. The termination cap shall be color-coded white to designate Category 6 performance and shall include a universal label coded for T568A and T568B wiring schemes.



technical information

Category 6/Class E performance:	Exceeds ANSI/TIA-568-C.2 Category 6 and ISO 11801 Class E channel requirements at swept frequencies up to 250 MHz Meets ANSI/TIA-568-C.2 and ISO 11801 Category 6 component requirements at swept frequencies up to 250 MHz
FCC compliance:	Complies with ANSI/TIA-1096A (formerly FCC Part 68); contacts plated with 50 microinches of gold
IEC compliance:	Meets IEC 60603-7 and IEC 60512-99-001
PoE compliance:	Rated for 2500 cycles with IEEE 802.3af / 802.3at and proposed 802.3bt type 3 and type 4 for up to 100W
c(UL)us Listed:	UL 1863, UL 1863 (Use as communications circuit accessory), CSA standard C22.2 UL 2043 (Suitable for use in air-handling spaces)
Operating temperature:	-10° C to 65° C (14°F to 149°F)
RoHS compliance:	Compliant
Conductor termination range:	Wire cap compatible with 22 – 26 AWG solid or stranded cable with conductor insulation diameters of 0.060 in. max and overall cable O.D. 0.200 in. to 0.330 in.; marine jack module wire cap compatible with 22 AWG solid or stranded cable with 0.071 in. (1.80mm) maximum insulated conductor outside diameter cable

key features and benefits

100% performance tested	Confidence that each jack module will deliver the critical electrical performance requirements
Utilizes enhanced Giga-TX™ Technology	Optimizes performance by eliminating conductor untwist and reduces installation time and expense
Improved termination cap	Conductor retention slots simplify jack module termination
Integral shield	Provides a 360° conductive path to ground shielded jack module with no additional assembly required
Snap in grounding	Shield provides seamless bonding of the jack module with Mini-Com® All Metal Modular Patch Panels
Modular	Shielded jack modules snap in and out of all Mini-Com® Faceplates, Metal Modular Patch Panels, and Surface Mount Boxes for easy moves, adds, and changes
Individually serialized	Marked with quality control number for future traceability
Identification	Can be clearly identified with optional labels and icons for port identification
Shuttered version (optional):	Integrated spring shuttered door keeps out dust and debris of un-mated RJ45 jack modules automatically
Marine compatible version available	Terminates to TX6000™ Shielded S/FTP Marine Copper Cable, which includes a durable flame-, oil-, UV- and MUD-resistant cable jacket; ideal for use in harsh environments encountered in marine applications including ship and offshore/ onshore units
Termination tools (optional)	EGJT termination tool ensures conductors are fully terminated by utilizing a smooth forward motion without impact on critical internal components for maximum reliability; TGJT termination tool ideal for high volume installations
Block out device (optional)	Provides a simple and secure method to control access to data ports while not in use

applications

Mini-Com® TX6™ PLUS Shielded Jack Modules are a component of the TX6000™ Shielded Copper Cabling System. This end-to-end system is interoperable and backwards compatible, providing design flexibility to protect network investments well into the future. With certified performance to the ANSI/TIA-568-C.2 Category 6 and ISO 11801 Class E standards, this system is ideal for today's high performance workstation applications. With certified performance to the

ANSI/TIA-568-C.2 Category 6 and ISO 11801 Class E standards, these systems will support the following applications:

- Ethernet 10BASE-T, 100BASE-T (Fast Ethernet), 1000BASE-T (Gigabit Ethernet)
- 155 Mb/s ATM, 622 Mb/s ATM, 1.2 Gb/s ATM
- Token Ring 4/16
- Digital video and broadband/baseband analog video
- Voice over Internet Protocol (VoIP)

TX6™ PLUS Shielded Copper Cabling System

Mini-Com® TX6™ PLUS Shielded Jack Modules

Jack module:	CJS688TG*Y
Shuttered jack module:	CJSH688TG*Y
Marine jack module:	CJSM688TG†

TX6™ Shielded Copper Cable

CM, F/UTP:	PFC6004***-KD
LSZH, F/UTP:	PFL6004+-KD
LSZH, SF/UTP:	PSFL6004+-KD

TX6000™ Shielded S/FTP Marine Copper Cable

LSZH:	PSM6004BU**+LED
--------------	-----------------

TX6A™ 10Gig™ Shielded CM/LSZH Patch Cords

Foot lengths:	STP6X*IG
Meter lengths:	STP6X*MIG

Mini-Com® Angled All Metal Modular Patch Panels

24-port, 1 RU:	CPA24BLY
48-port, 2 RU:	CPA48BLY
72-port, 2 RU:	CPA72BLY

Mini-Com® Flat All Metal Modular Patch Panels

24-port, 1 RU:	CP24BLY
48-port, 2 RU:	CP48BLY
72-port, 2 RU:	CP72BLY

Tools and Accessories

Jack module termination tool:	EGJT or TGJT
Wire snipping tool:	CWST
Wire stripping tool:	CJAST
Clear dust cap:	MDC-C
Block out device:	PSL-DCJB-***
Phone icons:	CIDIW-C+
Data icons:	CIDIW-C+

*To designate color, add BU (Blue), RD (Red), YL (Yellow), GR (Green) or VL (Violet). For part number CJS688TGY (no designation), the color is black.

†Offered in black only.

***To designate color, add suffix IG (International Gray) or LG (Light Gray).

*To designate color, add suffix WH (White) or DG (Dark Gray).

**To designate color, add suffix BL (Black) or IG (International Gray). For other cable colors, contact customer service.

†For lengths 3 to 20 feet (one foot increments) and 25, 30, 35, 40 feet, change the length designation in the part number to the desired length. For standard cable colors other than IG (International Gray), substitute the IG suffix with BL (Black), BU (Blue), RD (Red), YL (Yellow), GR (Green), OR (Orange) or VL (Violet). For example, the part number for a blue 15-foot patch cord is STP6X15BU.

**For lengths 1 to 10 meters (one meter increments) and 1.5, 2.5, 15, 20 meters, change the length designation in the part number to the desired length. For standard cable colors other than IG (International Gray), substitute the IG suffix with BL (Black), BU (Blue), RD (Red), YL (Yellow), GR (Green), OR (Orange) or VL (Violet). For example, the part number for a blue 15-meter patch cord is STP6X15MBU.

***To designate color other than Red, add suffix BL (Black), BU (Blue), YL (Yellow), GR (Green), OR (Orange), IW (Off White) or IG (International Gray) at the end of the part number. 10/package.

Contact customer service for bulk packaged and/or keyed jack modules and patch cords. Panduit recommends installing shielded jack modules in Mini-Com® All Metal Modular Patch Panels.

www.panduit.com

Mini-Com® TX6™ PLUS Shielded Jack Modules

Test Results

Mechanical Test	Test Method	Measurement	Typical Test Results
Normal Force	—	Load (grams)	> 100
Vibration	IEC 512-6d	Circuit Resistance (mOhms)	< 40
Shock	IEC 512-6c	Contact Disturbance (microsecond)	< 5
Durability	IEC 512-9a	Circuit Resistance (mOhms)	< 40
Mating/Un-mating	IEC 512-13b	Mating Force (N)	< 20
		Un-mating Force (N)	< 20
Termination Cycles	IEC 352	Number of Cycles	> 20
Mating Cycles	IEC 60603-7	Number of Plug Insertions	> 2500

Electrical Test	Test Method	Measurement	Typical Test Results
Low Level Circuit Resistance	IEC 512-2a	Resistance (mOhms)	< 20
Dielectric Withstand Voltage	IEC 512-4a	1000 V, 1 minute	Passed
Insulation Resistance	IEC 512-3a	Resistance (MOhms)	> 500

Environmental Test	Test Method	Measurement	Typical Test Results
Temperature Life	IEC 512-9b	Circuit Resistance (mOhms)	< 40
Humidity	IEC 512-11c	Circuit Resistance (mOhms)	< 40
Thermal Shock	IEC 512-11d	Circuit Resistance (mOhms)	< 40
Climatic Sequence	IEC 512-11a	Circuit Resistance (mOhms)	< 40
Flowing Mixed Gas Corrosion	IEC 512-11g	Circuit Resistance (mOhms)	< 40

Shielded Jack Module and Standard

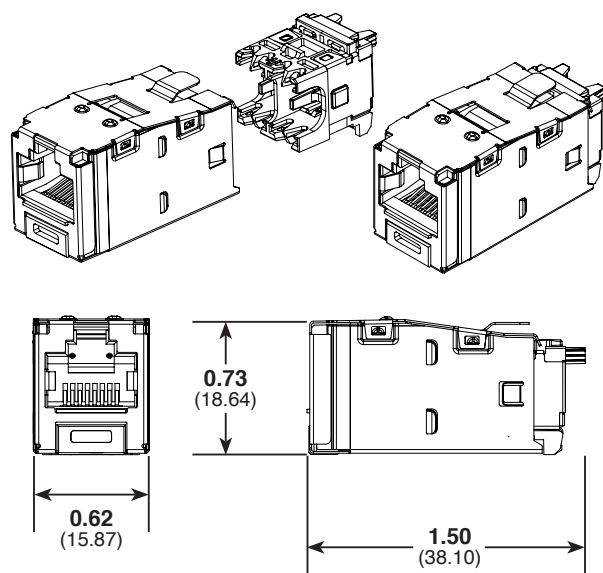

Shuttered Shielded Jack Module and Standard

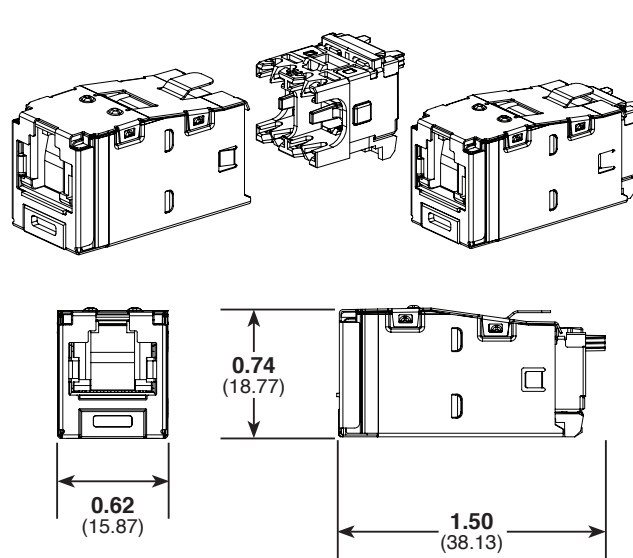

Dimensions are in inches (Dimensions in parenthesis are metric)

WORLDWIDE SUBSIDIARIES AND SALES OFFICES

PANDUIT CANADA
Markham, Ontario
cs-cdn@panduit.com
Phone: 800.777.3300

PANDUIT EUROPE LTD.
London, UK
cs-emea@panduit.com
Phone: 44.20.8601.7200

PANDUIT SINGAPORE PTE. LTD.
Republic of Singapore
cs-ap@panduit.com
Phone: 65.6305.7575

PANDUIT JAPAN
Tokyo, Japan
cs-japan@panduit.com
Phone: 81.3.6863.6000

PANDUIT LATIN AMERICA
Guadalajara, Mexico
cs-la@panduit.com
Phone: 52.33.3777.6000

PANDUIT AUSTRALIA PTY. LTD.
Victoria, Australia
cs-aus@panduit.com
Phone: 61.3.9794.9020

For a copy of Panduit product warranties, log on to www.panduit.com/warranty

For more information

Visit us at www.panduit.com

Contact Customer Service by email: cs@panduit.com
or by phone: 800.777.3300

PANDUIT®

©2015 Panduit Corp.
ALL RIGHTS RESERVED.
COSP315--WW-ENG
02/2016