

## GU (General Use) Type SOP Series [2-Channel (Form A) Type]

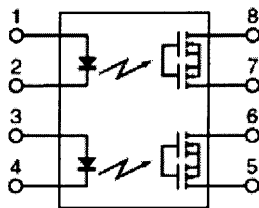
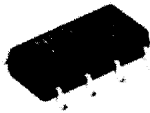

### FEATURES

#### 1. 2 channels in super miniature design

The device comes in a super-miniature SO package measuring (W)  $4.4 \times$  (L)  $9.37 \times$  (H)  $2.1$  mm (W)  $.173 \times$  (L)  $.369 \times$  (H)  $.083$  inch —approx. 38% of the volume and 66% of the footprint size of DIP type PhotoMOS Relays.

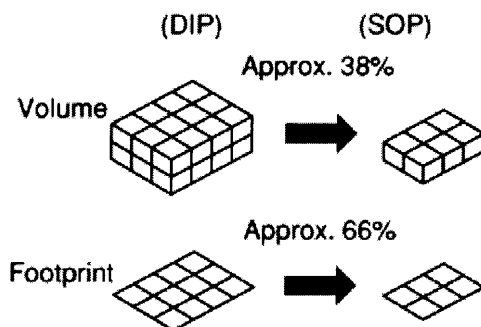

#### 2. Tape and reel

The device comes standard in a tape and reel (1,000 pcs./reel) to facilitate automatic insertion machines.

#### 3. Controls low-level analog signals

PhotoMOS relays feature extremely low closed-circuit offset voltage to enable control of low-level analog signals without distortion.

#### 4. Low-level off state leakage current

In contrast to the SSR with an off state leakage current of several milliamps, the PhotoMOS relay features a very small off state leakage current of only 100 pA even with the rated load voltage of 400 V (AQW214S)

## TYPICAL APPLICATIONS

Telephones  
 Measuring instruments  
 Computer  
 Industrial robots  
 High-speed inspection machines.

## TYPES

Packing quantity in tape and reel  
 1,000 pcs.

Notes:

- (1) Tape package is the standard packing style. Also available in tube. (Part No. suffix "X" or "Z" is not needed when ordering; Tube: 50 pcs.; Case: 1,000 pcs.)
- (2) For space reasons, the package type indicator "X" and "Z" are omitted from the seal.

\*Indicate the peak AC and DC values.

Type	Output rating*		Part No.	
	Load voltage	Load current	Picked from the 1/2/3/4-pin side	Picked from the 5/6/7/8-pin side
Load voltage	350 V	100 mA	AQW210SX	AQW210SZ
	400 V	80 mA	AQW214SX	AQW214SZ

RATING ...

DIMENSIONS ...

SCHEMATIC AND WIRING DIAGRAMS ...

CAUTIONS FOR USE ...

REFERENCE DATA ...

---

## REFERENCE DATA

### 1. Load current vs. ambient temperature characteristics

Allowable ambient temperature:

−40 to +85°C

−40 to +185°F

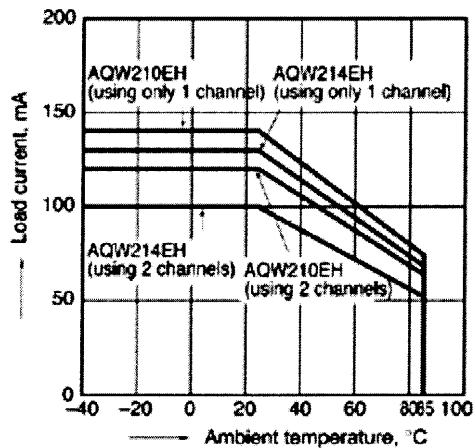

### 2. On resistance vs. ambient temperature characteristics

Measured portion: between terminals 5 and 6, 7 and 8;

LED current: 5 mA; Load voltage: Max. (DC);

Continuous load current: Max. (DC)

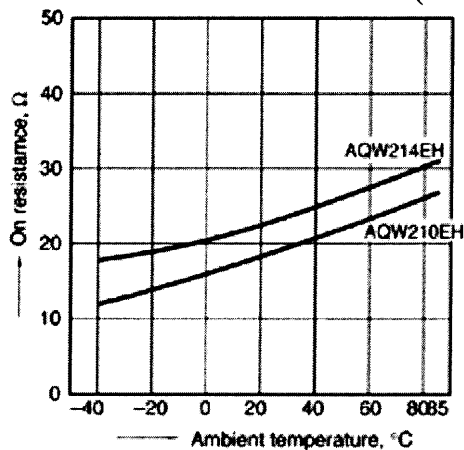

### 3. Turn on time vs. ambient temperature characteristics

Sample: All types

LED current: 5 mA; Load voltage: Max. (DC);

Continuous load current: Max. (DC)

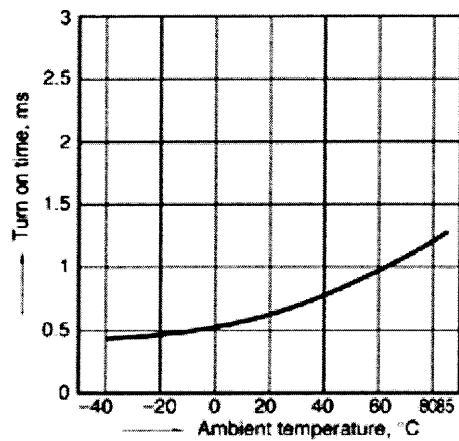

#### 4. Turn off time vs. ambient temperature characteristics

Sample: All types

LED current: 5 mA; Load voltage: Max. (DC);

Continuous load current: Max. (DC)

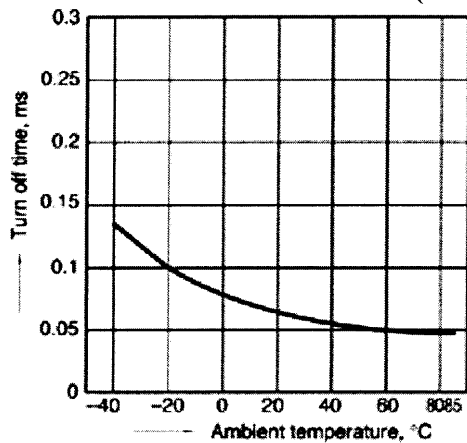

#### 5. LED operate current vs. ambient temperature characteristics

Sample: All types; Load voltage: Max. (DC);

Continuous load current: Max. (DC)

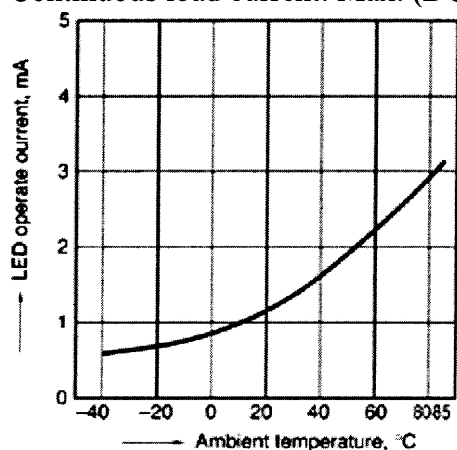

#### 6. LED turn off current vs. ambient temperature characteristics

Sample: All types; Load voltage: Max. (DC);

Continuous load current: Max. (DC)

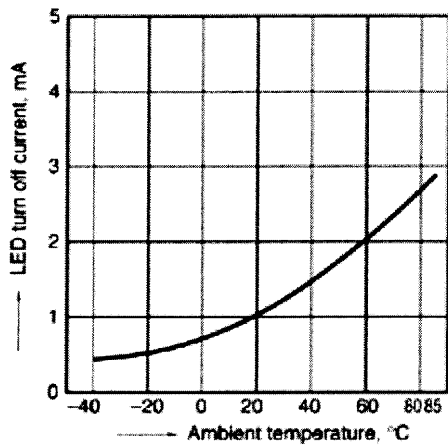

**7. LED dropout voltage vs. ambient temperature characteristics**

Sample: All types; LED current: 5 to 50 mA

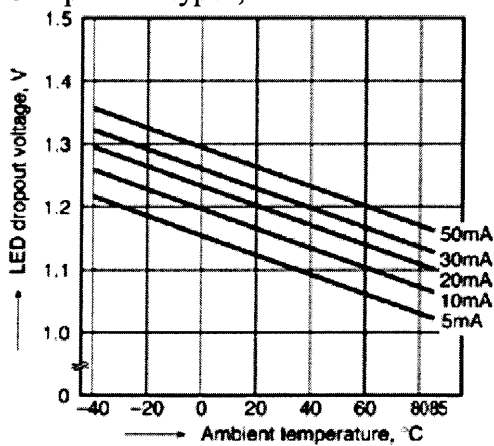

**8. Voltage vs. current characteristics of output at MOS portion**

Measured portion: between terminals 5 and 6, 7 and 8;

Ambient temperature: 25°C 77°F

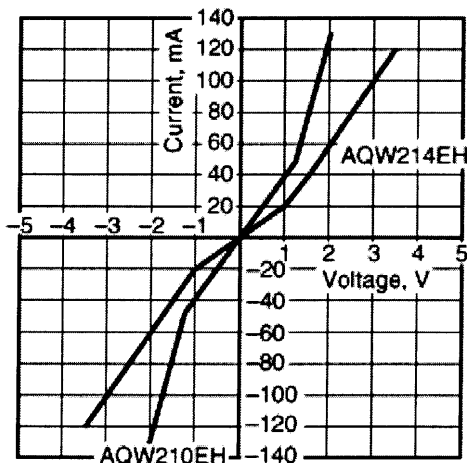

**9. Off state leakage current**

Measured portion: between terminals 5 and 6, 7 and 8;

Ambient temperature: 25°C 77°F

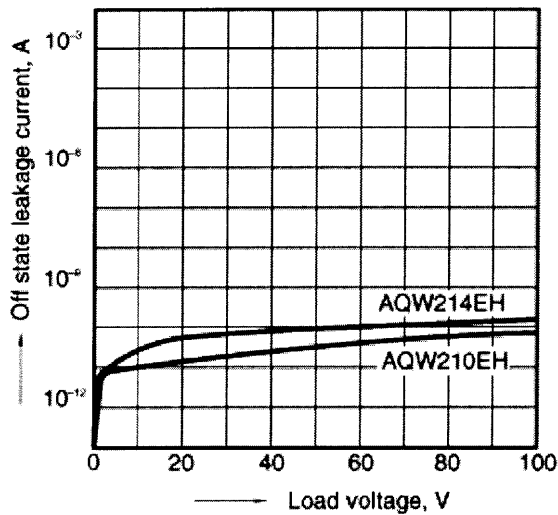

**10. LED forward current vs. turn on time characteristics**

Sample: All types

Measured portion: between terminals 5 and 6, 7 and 8;

Load voltage: Max. (DC);

Continuous load current: Max. (DC);

Ambient temperature: 25°C 77°F

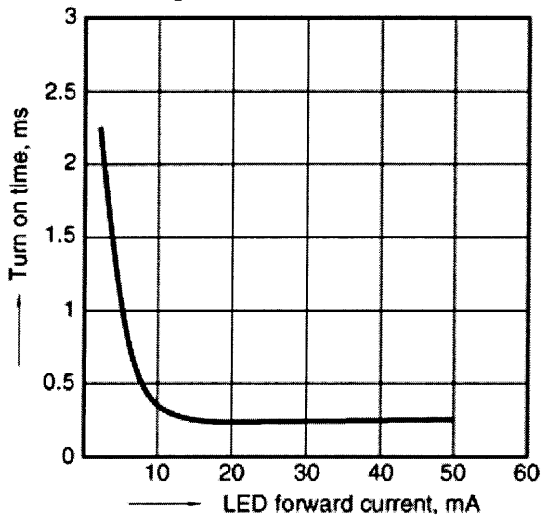

**11. LED forward current vs. turn off time characteristics**

Sample: All types

Measured portion: between terminals 5 and 6, 7 and 8;

Load voltage: Max. (DC);

Continuous load current: Max. (DC);

Ambient temperature: 25°C 77°F

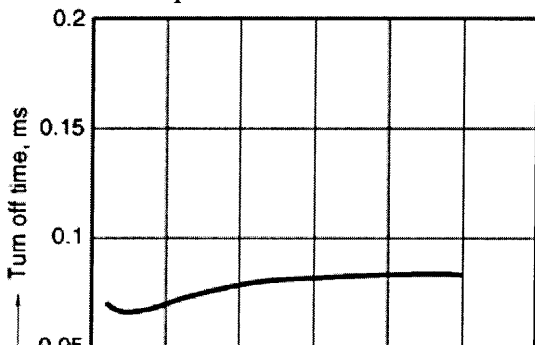

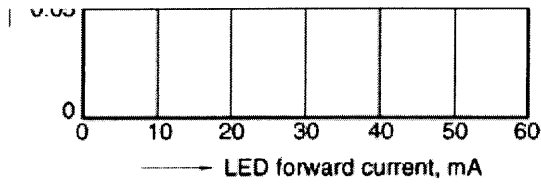

**12. Applied voltage vs. output capacitance characteristics**

Sample: All types

Measured portion: between terminals 5 and 6, 7 and 8;

Frequency: 1 MHz; Ambient temperature: 25°C 77°F

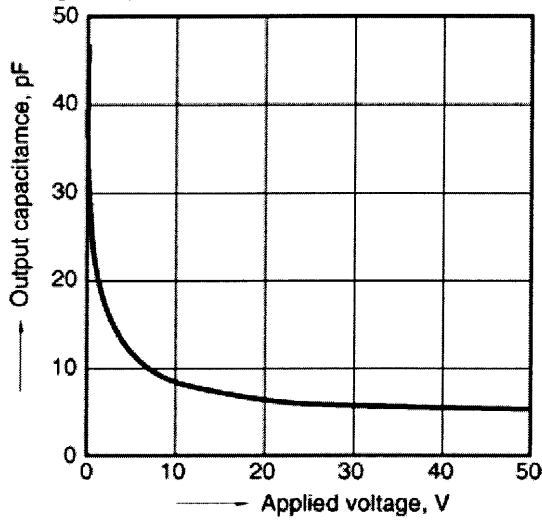

[◀Back](#)

## PhotoMOS Relays excluding Power PhotoMOS Relays

### SAFETY WARNINGS

Do not use the product under conditions that exceed the range of its specifications. It may cause overheating, smoke, or fire.

Do not touch the recharging unit while the power is on. There is a danger of electrical shock. Be sure to turn off the power when performing mounting, maintenance, or repair operations on the relay (including connecting parts such as the terminal board and socket).

Check the connection diagrams in the catalog and be sure to connect the terminals correctly. Erroneous connections could lead to unexpected operating errors, overheating, or fire.

#### 1. Unused terminals

The No. 3 terminal is used with the circuit inside the relay. Therefore, do not connect it to the external circuitry with either connection method A, B or C. (1a type)

#### 2. Short across terminals

Do not short circuit between terminals when relay is energized. There is possibility of breaking the internal IC.

#### 3. Surge voltages at the input

If reverse surge voltages are present at the input terminals, connect a diode in reverse parallel across the input terminals and keep the reverse voltages below the reverse breakdown voltage.

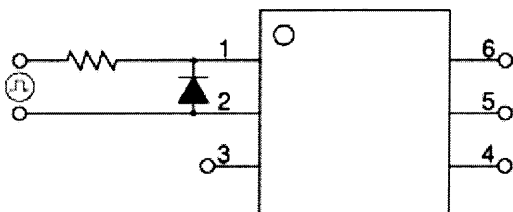

#### 4. Recommended LED forward current ( $I_F$ )

It is recommended that the LED forward current ( $I_F$ ) of each PhotoMOS Relay should be set according to the following table.

**DIP SMD type**

**Standard I/O isolation type (1,500 V AC)**

Type	Product name	Recommended LED forward current ( $I_F$ )



DIP (SMD) SOP	AQV10,20 Series	10 mA
	AQY21, 41 Series (SOP) AQV21, 41 Series (including SOP) AQV22 Series (including SOP) AQY22 Series (SSOP, SOP) AQV25, 45 Series <b>AQW21*</b> Series (including SOP) AQW41*, 61* Series (including SOP) AQW22 Series AQW25, 45, 65 Series AQS210PS Series AQS210TS Series AQS210T2S Series AQS225S Series AQS610TS Series	5mA
	AQY21*H, 41*H Series AQY210HL Series AQY27 Series AQW27 Series AQV21*H Series AQV210HL Series AQV25*H, 45*H Series <b>AQW21*</b> H, 41*H, 61*H Series AQW210HL Series	5 to 10mA
	AQV23 Series	2 mA
SIL	AQX21 Series	5 mA
	AQZ10, 20, 40 Series AQZ26 Series	5 to 10 mA

### 5. Ripple in the input power supply

If ripple is present in the input power supply, observe the following:

- 1) For LED operate current at  $E_{min}$ , maintain the value mentioned in the table of "4. Recommended LED forward current ( $I_F$ )."
- 2) Keep the LED operate current at 50 mA (25 mA for PhotoMOS HE Relay with LED display type) or less at  $E_{max}$ .

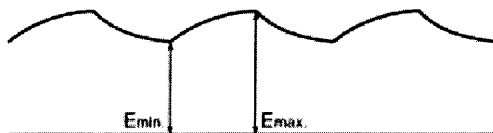

### 6. Output spike voltages

- 1) If an inductive load generates spike voltages which exceed the absolute maximum rating, the spike voltage must be limited. Typical circuits are shown below.

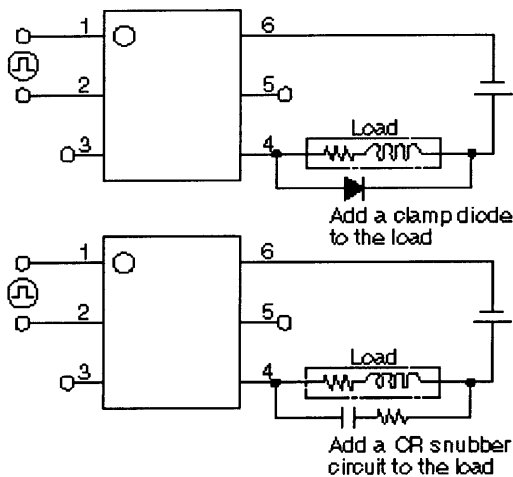

2) If spike voltages generated at the load are limited with a clamp diode and the circuit wires are long, spike voltages will occur by inductance. Keep wires as short as possible to minimize inductance.

**7. Cleaning solvents compatibility**

Dip cleaning with an organic solvent is recommended for removal of solder flux, dust, etc. Select a cleaning solvent from the following table. If ultrasonic cleaning is used, the severity of factors such as frequency, output power and cleaning solvent selected may cause loose wires and other defects. Make sure these conditions are correct before use. For details, please consult us.

Cleaning solvent		Compatibility (Y: Yes N: No)
Chlorine base	Trichlene Chloroethylene	Y
Adueous	Indusco Hollis Lonco Terg	Y
Alcohol base	IPA Ethanol	Y
Others	Thinner Gasoline	N

**8. Input wiring pattern**

With AQY or AQW types\*, AQS210PS, AQS225S series avoid installing the input (LED side) wiring pattern to the bottom side of the package if you require the specified I/O isolation voltage ( $V_{iso}$ ) after mounting the PC board. Since part of the frame on the output side is exposed, it may cause fluctuations in the I/O isolation voltage.

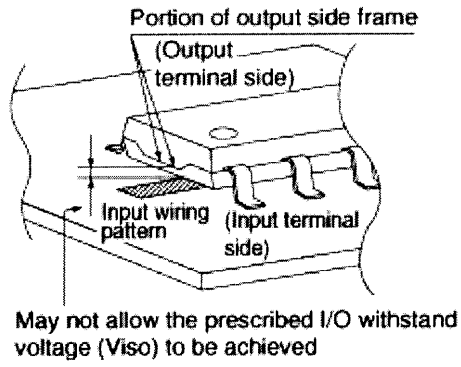

\*except for GU-E (Reinforced 5,000V) type

### 9. Soldering

- 1) When soldering PC board terminals, keep soldering time to within 10 s at 260°C 500°F .
  - 2) When soldering surface-mount terminals, the following conditions are recommended.
- (1) IR (Infrared reflow) soldering method

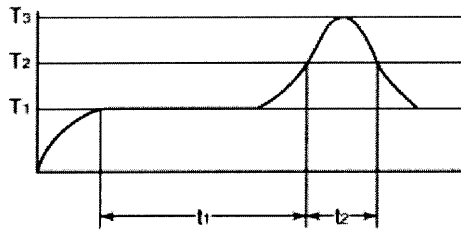

T<sub>1</sub> = 155 to 165°C 311 to 329°F  
 T<sub>2</sub> = 180°C 200°C 356 to 392°F  
 T<sub>3</sub> = 245°C 473°F or less  
 t<sub>1</sub> = 120 s or less  
 t<sub>2</sub> = 30 s or less

(2) Vapor phase soldering method

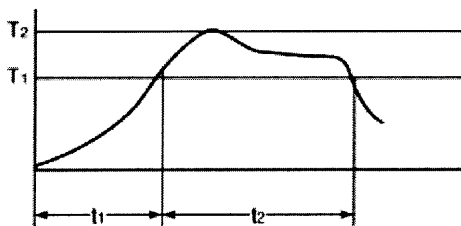

T<sub>1</sub> = 180 to 200°C 366 to 392°F  
 T<sub>2</sub> = 215°C 419°F or less  
 t<sub>1</sub> = 40 s  
 t<sub>2</sub> = 90 s or less (40 s or less for SOP type)

(3) Double wave soldering method

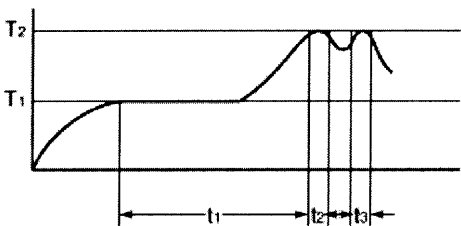

T<sub>1</sub> = 155 to 165°C 311 to 329°F  
 T<sub>2</sub> = 260°C 500°F or less

t1 = 60 s or less  
t2+t3 = 5 s or less

(4) Soldering iron method

Tip temperature: 280 to 300°C 536 to 572°F

Wattage: 30 to 60 W

Soldering time: within 5 s

(5) Others

Check mounting conditions before using other soldering methods (hot-air, hot plate, pulse heater, etc.)

The temperature profile indicates the temperature of the soldered terminal on the surface of the PC board. The ambient temperature may increase excessively. Check the temperature under mounting conditions.

The conditions for the infrared reflow soldering apply when preheating using the VPS method.

10. The following shows the packaging format

1) Tape and reel

mm inch

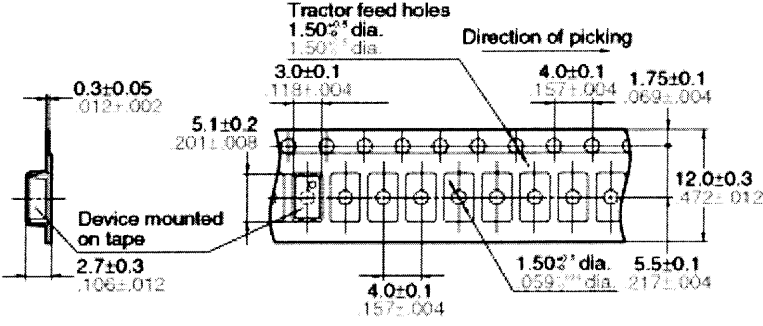
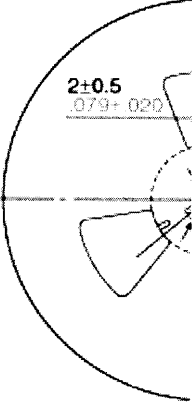
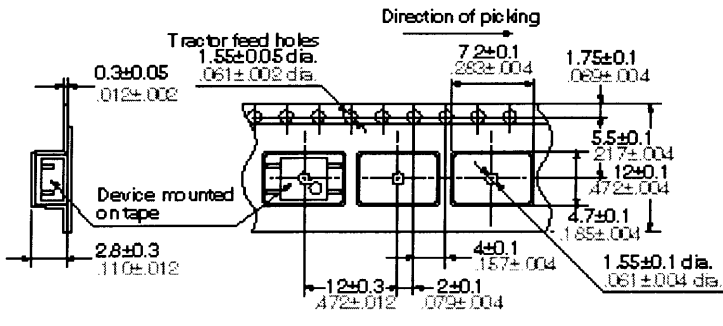
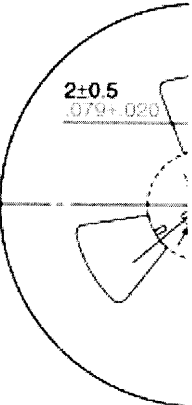
Type	Tape dimensions	Dimensions of p
<p>SSOP 4-pin type</p>	 <p>Tractor feed holes 1.50±0.1 dia. 1.50±0.1 dia.</p> <p>Direction of picking</p> <p>0.3±0.05 .012±.002</p> <p>3.0±0.1 11.8±.004</p> <p>5.1±0.2 201±.008</p> <p>4.0±0.1 1.57±.004</p> <p>1.75±0.1 .069±.004</p> <p>12.0±0.3 .472±.012</p> <p>2.7±0.3 .106±.012</p> <p>4.0±0.1 .157±.004</p> <p>1.50±0.1 dia. .059±.004 dia.</p> <p>5.5±0.1 .217±.004</p> <p>Device mounted on tape</p> <p>(1) When picked from 1/4-pin side: Part No. AQY○○○SY (Shown above) (2) When picked from 2/3-pin side: Part No. AQY○○○SW</p>	 <p>2±0.5 .079±.020</p>
<p>SO package 4-pin type</p>	 <p>Tractor feed holes 1.55±0.05 dia. 1.55±0.05 dia.</p> <p>Direction of picking</p> <p>0.3±0.05 .012±.002</p> <p>7.2±0.1 .283±.004</p> <p>1.75±0.1 .089±.004</p> <p>5.5±0.1 .217±.004</p> <p>1.12±0.1 .472±.004</p> <p>4.7±0.1 .185±.004</p> <p>4±0.1 .157±.004</p> <p>1.55±0.1 dia. .061±.004 dia.</p> <p>2.8±0.3 .110±.012</p> <p>12±0.3 .472±.012</p> <p>2±0.1 .079±.004</p> <p>Device mounted on tape</p> <p>(1) When picked from 1/2-pin side: Part No. AQY○○○SX (Shown above) (2) When picked from 3/4-pin side: Part No. AQY○○○SZ</p>	 <p>2±0.5 .079±.020</p>

SO  
package 6-  
pin type

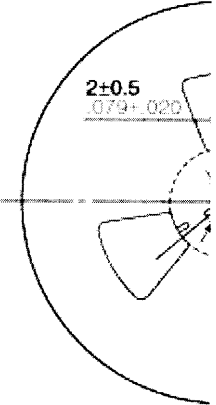
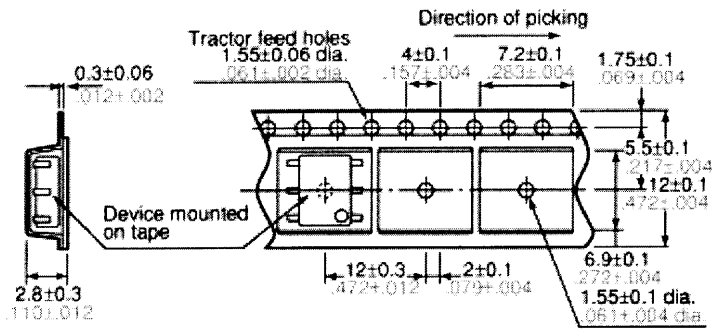

- (1) When picked from 1/2/3-pin side: Part No. AQV○○○SX  
(Reel color: blue) (Shown above)
- (2) When picked from 4/5/6-pin side: Part No. AQV○○○SZ  
(Reel color: orange)

SO  
package 8-  
pin type

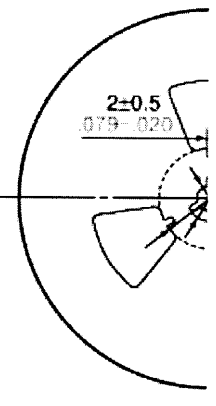
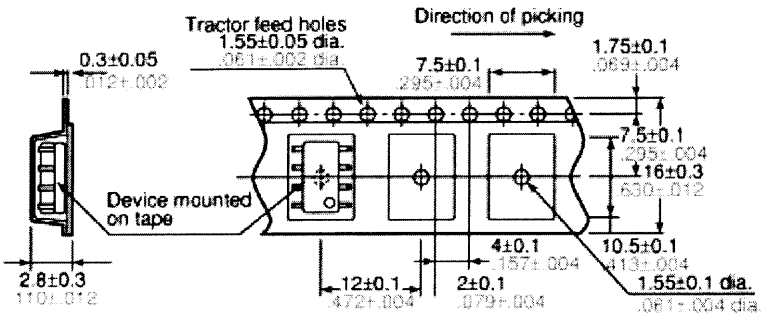

- (1) When picked from 1/2/3/4-pin side: Part No. AQW○○○SX  
(Shown above)
- (2) When picked from 5/6/7/8-pin side: Part No. AQW○○○SZ

SO  
package  
12-pin  
type

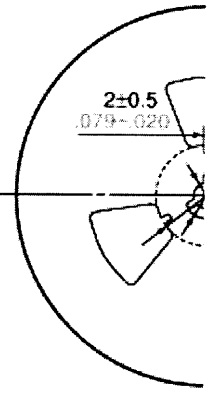
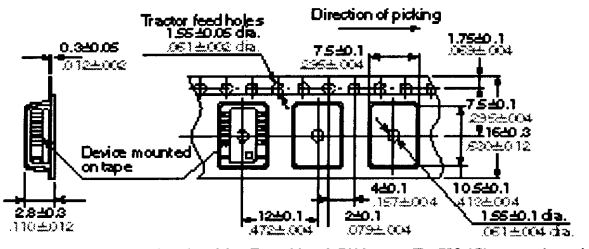

- (1) When picked from 1/2/3/4/5/6-pins side: Part No. AQW○○○T2SX (Shown above)
- (2) When picked from 7/8/9/10/11/12-pin side: Part No. AQW○○○T2SZ

SO package  
16-pin  
type

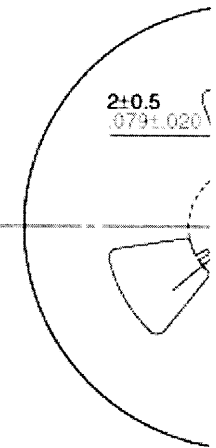
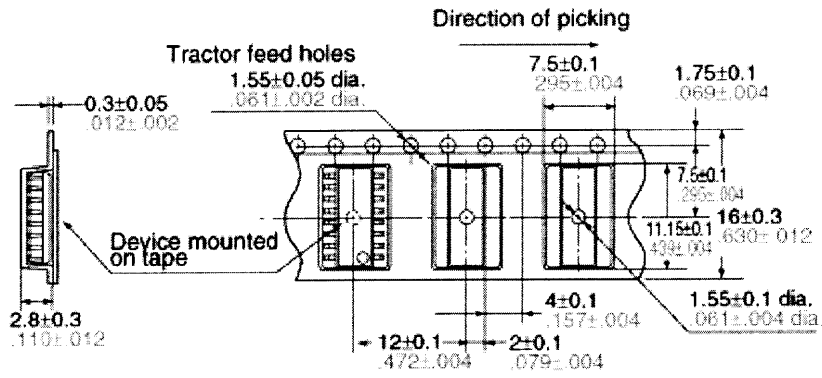

- (1) When picked from 1/2/3/4/5/6/7/8-pin side: Part No. AQS210○(2)SX (Shown above)
- (2) When picked from 9/10/11/12/13/14/15/16-pin side: Part No. AQS210○(2)SZ

PD 4-pin  
SMD type

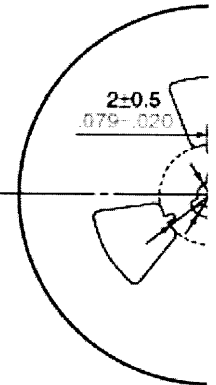
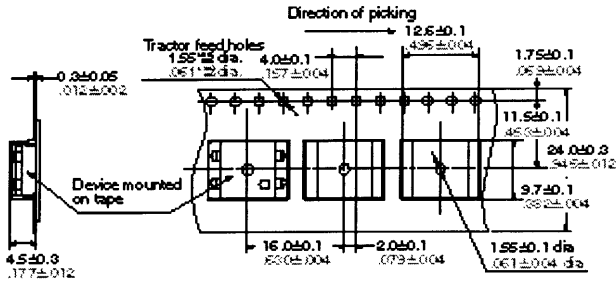

- (1) When picked from 1/2-pin side: Part No. AQY○○○AX (Shown above)
- (2) When picked from 3/4-pin side: Part No. AQY○○○AZ

PD 8-pin  
SMD type

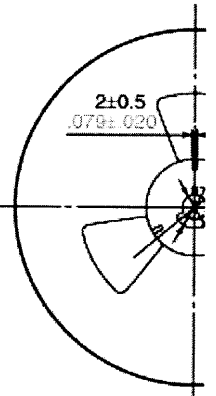
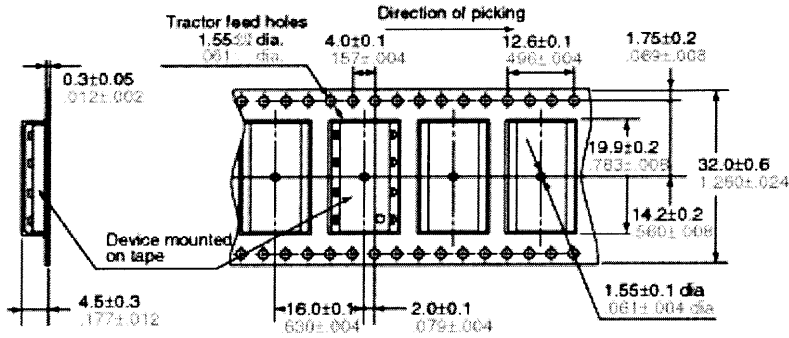

- (1) When picked from 1/2/3/4-pin side: Part No. AQW○○○AX (Shown above)
- (2) When picked from 5/6/7/8-pin side: Part No. AQW○○○AZ

4-pin SMD type

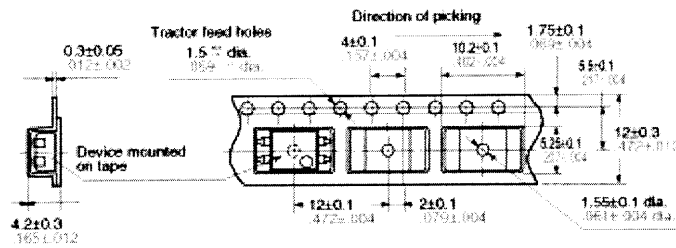

- (1) When picked from 1/2-pin side: Part No. AQY○○○EHAX, AQY210HLAX (Shown above)
- (2) When picked from 3/4-pin side: Part No. AQY○○○EHAZ, AQY210HLAZ

2±0.5  
0.79±0.020

8-pin SMD type

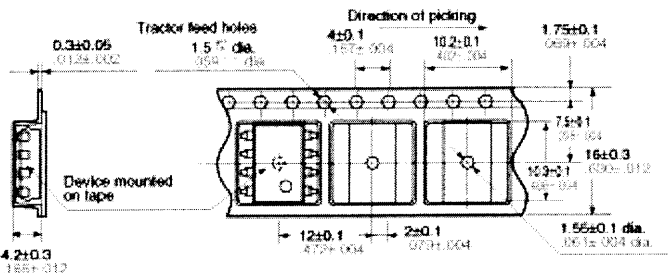

- (1) When picked from 1/2/3/4-pin side: Part No. AQW○○○EHAX, AQW210HLAX (Shown above)
- (2) When picked from 5/6/7/8-pin side: Part No. AQW○○○EHAZ, AQW210HLAZ

2±0.5  
0.79±0.020

6-pin SMD type

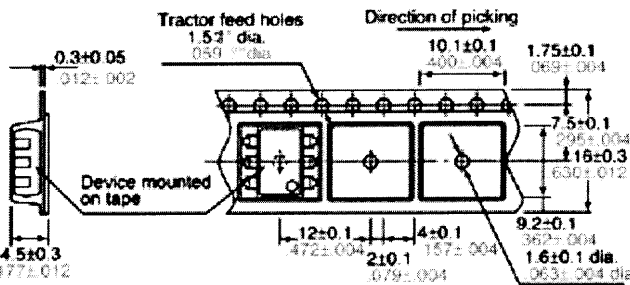

- (1) When picked from 1/2/3-pin side: Part No. AQV○○○DAX (Shown above)
- (2) When picked from 4/5/6-pin side: Part No. AQV○○○DAZ

2±0.5  
0.79±0.020

8-pin SMD type

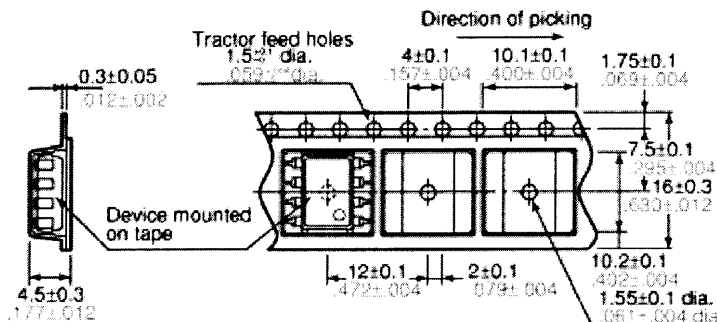

2±0.5  
0.79±0.020

<p>(1) When picked from 1/2/3/4-pin side: Part No. AQW○○○AX (Shown above)</p> <p>(2) When picked from 5/6/7/8-pin side: Part No. AQW○○○AZ</p>	
---	---

## 2) Tube

(1) Devices are packaged in a tube so pin No. 1 is on the stopper B side. Observe correct orientation when mounting them on PC boards.

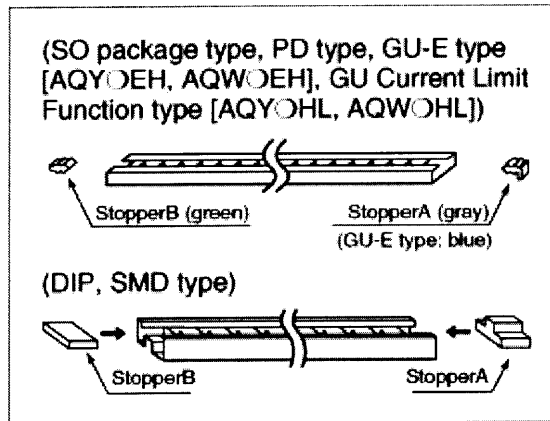

## 2) Storage

PhotoMOS relays implemented in SSO, SO packages are sensitive to moisture and come in sealed moisture-proof packages. Observe the following cautions on storage.

After the moisture-proof package is unsealed, take the devices out of storage as soon as possible (within 1 month at the most).

If the devices are to be left in storage for a considerable period after the moisture-proof package has been unsealed, it is recommended to keep them in another moisture-proof bag containing silica gel (within 3 months at the most).

## 11. Transportation and storage

1) Extreme vibration during transport will warp the lead or damage the relay. Handle the outer and inner boxes with care.

2) Storage under extreme conditions will cause soldering degradation, external appearance defects, and deterioration of the characteristics. The following storage conditions are recommended:

Temperature: 0 to 45°C 32 to 113°F

Humidity: Less than 70% R.H.

Atomosphere: No harmful gasses such as sulfurous acid gas, minimal dust.

## 12. Current limit function (output current control)

1) Current limit function aims to increase resistance to surges when the switch is turned on. Before using this function, connect the varistor to the output as shown in the figure below.



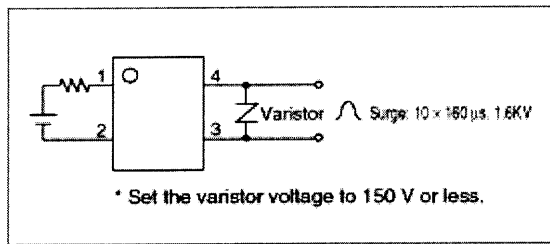

2) The current limit function capability can be lost if used longer than the specified time. Be sure to set the output loss to the max. rate.

### 13. Applying stress that exceeds the absolute maximum rating

If the voltage or current value for any of the terminals exceeds the absolute maximum rating, internal elements will deteriorate because of the excessive voltage or current. In extreme cases, wiring may melt, or silicon P/N junctions may be destroyed.

As a result, the design should ensure that the absolute maximum ratings will never be exceeded, even momentarily.

### 14. Deterioration and destruction caused by discharge of static electricity (RF C×R10, 20 types)

This phenomenon is generally called static electricity destruction. This occurs when static electricity generated by various factors is discharged while the relay terminals are in contact. The result can producing internal destruction of the element.

To prevent problems from static electricity, the following precautions and measures should be taken when using your device.

- 1) Employees handling relays should wear anti-static clothing and should be grounded through protective resistance of 500 k ohm to 1 M ohm.
- 2) A conductive metal sheet should be placed over the work table. Measuring instruments and jigs should be grounded.
- 3) When using soldering irons, either use irons with low leakage current, or ground the tip of the soldering iron. (Use of low-voltage soldering irons is also recommended.)
- 4) Devices and equipment used in assembly should also be grounded.
- 5) When packing printed circuit boards and equipment, avoid using high-polymer materials such as foam styrene, plastic, and other materials which carry an electrostatic charge.
- 6) When storing or transporting relays, the environment should not be conducive to generating static electricity (for instance, the humidity should be between 45 and 60%). Relay should always be protected by using non-conductive packing materials.

### 15. Short circuit protection circuit

The short circuit protection circuit is designed to protect circuits from excess current. Therefore, surge current may be detected as current overload in which case the output current will be cut and the off state maintained. For this reason, please include the inrush current in the load current and keep it below the maximum load current. Also, in order to maintain stability of internal IC operation, maintain an input current of at least 5 mA.

[◀Back](#)