

CJD44H11 NPN
CJD45H11 PNP

COMPLEMENTARY SILICON
POWER TRANSISTOR

DKPAK
POWER!

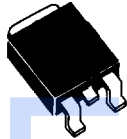

DKPAK CASE

CentralTM
Semiconductor Corp.

DESCRIPTION:

The CENTRAL SEMICONDUCTOR CJD44H11, CJD45H11 types are Complementary Silicon Power Transistors manufactured in a surface mount package designed for switching and power amplifier applications.

MAXIMUM RATINGS ($T_C=25^\circ\text{C}$)

	SYMBOL		UNITS
Collector-Emitter Voltage	V_{CEO}	80	V
Emitter-Base Voltage	V_{EBO}	5.0	V
Continuous Collector Current	I_C	8.0	A
Peak Collector Current	I_{CM}	16	A
Power Dissipation ($T_C=25^\circ\text{C}$)	P_D	20	W
Power Dissipation ($T_A=25^\circ\text{C}$)	P_D	1.75	W
Operating and Storage			
Junction Temperature	T_J, T_{stg}	-65 to +150	$^\circ\text{C}$
Thermal Resistance	θ_{JC}	6.25	$^\circ\text{C/W}$
Thermal Resistance	θ_{JA}	71.4	$^\circ\text{C/W}$

ELECTRICAL CHARACTERISTICS ($T_C=25^\circ\text{C}$ unless otherwise noted)

SYMBOL	TEST CONDITIONS	MIN	TYP	MAX	UNITS
I_{CES}	$V_{CE}=80\text{V}$			10	μA
I_{EBO}	$V_{EB}=5.0\text{V}$			50	μA
BV_{CEO}	$I_C=30\text{mA}$	80			V
$V_{CE(SAT)}$	$I_C=8.0\text{A}, I_B=400\text{mA}$			1.0	V
$V_{BE(SAT)}$	$I_C=8.0\text{A}, I_B=800\text{mA}$			1.5	V
h_{FE}	$V_{CE}=1.0\text{V}, I_C=2.0\text{A}$	60			
h_{FE}	$V_{CE}=1.0\text{V}, I_C=4.0\text{A}$	40			
f_T	$V_{CE}=10\text{V}, I_C=500\text{mA}, f=20\text{MHz}$ (CJD44H11)		60		MHz
f_T	$V_{CE}=10\text{V}, I_C=500\text{mA}, f=20\text{MHz}$ (CJD45H11)		50		MHz
C_{ob}	$V_{CB}=10\text{V}, I_E=0, f=0.1\text{MHz}$ (CJD44H11)		120		pF
C_{ob}	$V_{CB}=10\text{V}, I_E=0, f=0.1\text{MHz}$ (CJD45H11)		220		pF
$t_d + t_r$	$I_C=5.0\text{A}, I_{B1}=500\text{mA}$ (CJD44H11)		320		ns
$t_d + t_r$	$I_C=5.0\text{A}, I_{B1}=500\text{mA}$ (CJD45H11)		150		ns

SYMBOL	TEST CONDITIONS	MIN	TYP	MAX	UNITS
t_s	$I_C=5.0A, I_{B1}=I_{B2}=500mA$ (CJD44H11, CJD45H11)		450		ns
t_f	$I_C=5.0A, I_{B1}=I_{B2}=500mA$ (CJD44H11)		130		ns
t_r	$I_C=5.0A, I_{B1}=I_{B2}=500mA$ (CJD45H11)		100		ns

All dimensions in inches (mm).

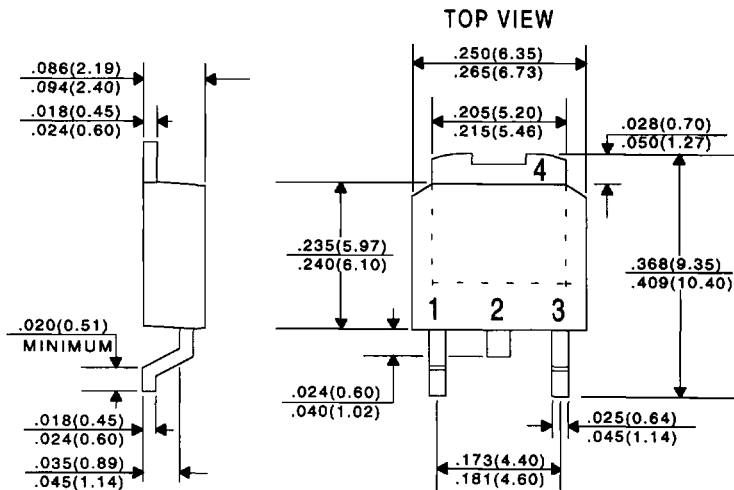

LEAD CODE:

- 1) BASE
- 2) COLLECTOR
- 3) EMITTER
- 4) COLLECTOR

DATA SHEET