

# 2N3771 JANTX, JTXV

# 2N3772 JANTX, JTXV



Processed per MIL-PRF-19500/413

## NPN HIGH-POWER SILICON TRANSISTORS

### MAXIMUM RATINGS

Ratings	Symbol	2N3771	2N3772	Units
Collector-Emitter Voltage	$V_{CEO}$	40	60	Vdc
Collector-Base Voltage	$V_{CBO}$	50	100	Vdc
Emitter-Base Voltage	$V_{EBO}$	7.0	7.0	Vdc
Base Current	$I_B$	7.5	5.0	Adc
Collector Current	$I_C$	30	20	Adc
Total Power Dissipation @ $T_A = 25^{\circ}C$ <sup>(1)</sup> @ $T_C = 25^{\circ}C$ <sup>(2)</sup>	$P_T$	6.0		W
		150		W
Operating & Storage Junction Temperature Range	$T_J, T_{stg}$	-65 to +200		$^{\circ}C$

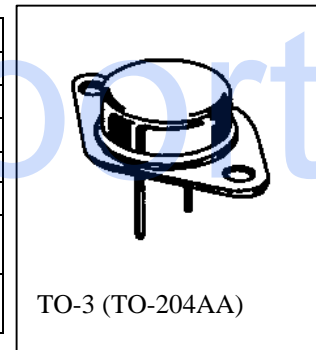

1) Derate linearly 34.2 mW/ $^{\circ}C$  for  $T_A > 25^{\circ}C$

2) Derate linearly 857 mW/ $^{\circ}C$  for  $T_C > 25^{\circ}C$

### ELECTRICAL CHARACTERISTICS ( $T_A = 25^{\circ}C$ unless otherwise noted)

Characteristics	Symbol	Min.	Max.	Unit
<b>OFF CHARACTERISTICS</b>				
Collector-Base Breakdown Voltage $I_C = 200$ mAdc	2N3771 2N3772	$V_{(BR)CEO}$	40 60	Vdc
Collector-Emitter Breakdown Voltage $I_C = 200$ mAdc, $R_{BE} = 100 \Omega$	2N3771 2N3772	$V_{(BR)CER}$	45 70	Vdc
Collector-Emitter Breakdown Voltage $I_C = 200$ mAdc, $V_{BE} = -1.5$ Vdc	2N3771 2N3772	$V_{(BR)CEX}$	50 90	Vdc
Collector-Emitter Cutoff Current $V_{CE} = 30$ Vdc $V_{CE} = 50$ Vdc	2N3771 2N3772	$I_{CEO}$	5.0 5.0	mAdc
Emitter-Base Cutoff Current $V_{BE} = 7.0$ Vdc	2N3771 2N3772	$I_{EBO}$	2.0	mAdc
Collector-Emitter Cutoff Current $V_{BE} = 1.5$ Vdc, $V_{CE} = 50$ Vdc $V_{BE} = 1.5$ Vdc, $V_{CE} = 100$ Vdc	2N3771 2N3772	$I_{CEX}$	500 500	$\mu$ Adc

2N3771, 2N3772 JAN SERIES

**ELECTRICAL CHARACTERISTICS (con't)**

Characteristics	Symbol	Min.	Max.	Unit
<b>ON CHARACTERISTICS <sup>(3)</sup></b>				
Forward-Current Transfer Ratio I <sub>C</sub> = 15 Adc, V <sub>CE</sub> = 4.0 Vdc I <sub>C</sub> = 10 Adc, V <sub>CE</sub> = 4.0 Vdc I <sub>C</sub> = 1.0 Adc, V <sub>CE</sub> = 4.0 Vdc	h <sub>FE</sub>	15 15 40	60 60 -	
Collector-Emitter Saturation Voltage I <sub>C</sub> = 15 Adc, I <sub>B</sub> = 1.5 Adc I <sub>C</sub> = 30 Adc, I <sub>B</sub> = 6.0 Adc I <sub>C</sub> = 10 Adc, I <sub>B</sub> = 1.0 Adc I <sub>C</sub> = 20 Adc, I <sub>B</sub> = 4.0 Adc	V <sub>CE(sat)</sub>		1.5 4.0 1.2 4.0	Vdc
Base-Emitter Voltage (nonsaturated) I <sub>C</sub> = 15 Adc, V <sub>CE</sub> = 4.0 Vdc I <sub>C</sub> = 10 Adc, V <sub>CE</sub> = 4.0 Vdc	V <sub>BE</sub>		2.3 2.0	Vdc

**DYNAMIC CHARACTERISTICS**

Small-Signal Cutoff Frequency I <sub>C</sub> = 1.0 Adc, V <sub>CE</sub> = 10 Vdc, f = 1.0 kHz	h <sub>fe</sub>	40		
Magnitude of Common Emitter Small-Signal Short-Circuit Forward-Current Transfer I <sub>C</sub> = 1.0 Adc, V <sub>CE</sub> = 4.0 Vdc, f = 100 kHz	h <sub>fe</sub>	6.0	30	
Output Capacitance V <sub>CB</sub> = 10 Vdc, I <sub>E</sub> = 0, 100 kHz ≤ f ≤ 1.0 MHz	C <sub>obo</sub>		1200	p <sup>f</sup>

**SWITCHING CHARACTERISTICS**

Turn-On Time V <sub>CC</sub> = 30 Vdc; I <sub>C</sub> = 15 Adc; I <sub>B1</sub> = 1.5 Adc V <sub>CC</sub> = 30 Vdc; I <sub>C</sub> = 10 Adc; I <sub>B1</sub> = 1.0 Adc	t <sub>on</sub>		10 8.0	μs
Turn-Off Time V <sub>CC</sub> = 30 Vdc; I <sub>C</sub> = 15 Adc; I <sub>B1</sub> = 1.5 Adc; I <sub>B2</sub> = -1.5 Adc V <sub>CC</sub> = 30 Vdc; I <sub>C</sub> = 10 Adc; I <sub>B1</sub> = 1.0 Adc; I <sub>B2</sub> = -1.0 Adc	t <sub>off</sub>		12 10	μs

**SAFE OPERATING AREA**

<p><b>DC Tests</b> T<sub>C</sub> = +25°C, 1 Cycle, t = 1.0 s</p> <p><b>Test 1 (2N3771 only)</b> V<sub>CE</sub> = 5.0 Vdc, I<sub>C</sub> = 30 Adc</p> <p><b>Test 2 (2N3771 only)</b> V<sub>CE</sub> = 40 Vdc, I<sub>C</sub> = 3.75 Adc</p> <p><b>Test 3 (2N3772 only)</b> V<sub>CE</sub> = 7.5 Vdc, I<sub>C</sub> = 20 Adc</p> <p><b>Test 4 (2N3772 only)</b> V<sub>CE</sub> = 60 Vdc, I<sub>C</sub> = 2.5 Adc</p> <p><b>Clamped Inductive</b> T<sub>A</sub> = +25°C; duty cycle ≤ 10%; R<sub>S</sub> = 0.1 Ω</p> <p><b>Test 1 (2N3771 only)</b> R<sub>BB1</sub> = 2.0 Ω; V<sub>BB1</sub> ≤ 14 Vdc; R<sub>BB2</sub> = 100 Ω; V<sub>CC</sub> = 20±5.0 Vdc; V<sub>BB2</sub> = 1.5 Vdc; I<sub>C</sub> = 30 Adc; R<sub>L</sub> ≤ 0.67 Ω; L = 5.0 mH</p> <p><b>Test 2 (2N3772 only)</b> R<sub>BB1</sub> = 2.0 Ω; V<sub>BB1</sub> ≤ 10 Vdc; R<sub>BB2</sub> = 100 Ω; V<sub>CC</sub> = 40±5.0 Vdc; V<sub>BB2</sub> = 1.5 Vdc; I<sub>C</sub> = 20 Adc; R<sub>L</sub> ≤ 2.0 Ω; L = 5.0 mH</p>
---

(3) Pulse Test: Pulse Width = 300μs, Duty Cycle ≤ 2.0%.