

BZW06-5V8 ... BZW06-376B Transient Voltage Suppressor Diodes Spannungs-Begrenzer-Dioden	P_{PPM} = 600W P_{M(AV)} = 5.0 W T_{jmax} = 175°C	V_{WM} = 5.0 ... 376 V V_{BR} = 6.8 ... 440 V
--	--	--

Version 2020-03-19

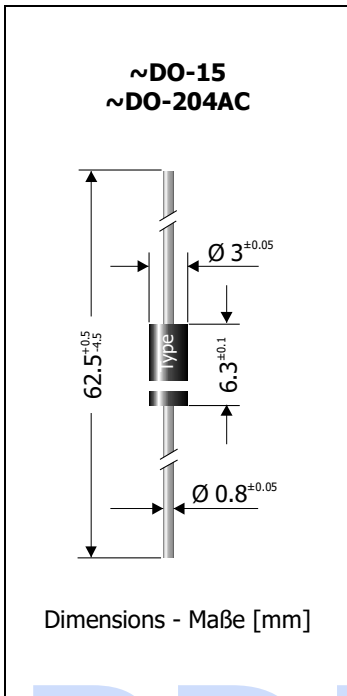

Typical Applications

- Over-voltage protection
- ESD protection
- Free-wheeling diodes
- Commercial grade
- Suffix -Q: AEC-Q101 compliant ¹⁾
- Suffix -AQ: in AEC-Q101 qualification ¹⁾

Features

- Uni- and Bidirectional versions
- Peak pulse power of 600 W (10/1000 µs waveform)
- Very fast response time
- Compliant to RoHS, REACH, Conflict Minerals ¹⁾

Mechanical Data ¹⁾

Taped in ammo pack	4000
Weight approx.	0.4 g
Case material	UL 94V-0
Solder & assembly conditions	260°C/10s MSL N/A



Typische Anwendungen

- Schutz gegen Überspannung
- ESD-Schutz
- Freilauf-Dioden
- Standardausführung
- Suffix -Q: AEC-Q101 konform ¹⁾
- Suffix -AQ: in AEC-Q101 Qualifikation ¹⁾

Besonderheiten

- Uni- und Bidirektionale Versionen
- 600 W Impuls-Verlustleistung (10/1000 µs Strom-Impuls)
- Sehr schnelle Ansprechzeit
- Konform zu RoHS, REACH, Konfliktmineralien ¹⁾

Mechanische Daten ¹⁾

Gegurtet in Ammo-Pack	
Gewicht ca.	
Gehäusematerial	
Löt- und Einbaubedingungen	

For bidirectional types (add suffix "B"), electrical characteristics apply in both directions.
Für bidirektionale Dioden (ergänze Suffix "B") gelten die elektrischen Werte in beiden Richtungen.

Maximum ratings ²⁾

Grenzwerte ²⁾

Peak pulse power dissipation (10/1000 µs waveform) Impuls-Verlustleistung (Strom-Impuls 10/1000 µs)		P _{PPM}	600 W ³⁾
Steady state power dissipation – Verlustleistung im Dauerbetrieb	T _A = 75°C	P _{M(AV)}	5 W ⁴⁾
Peak forward surge current Stoßstrom in Fluss-Richtung	Half sine-wave Sinus-Halbwelle	I _{FSM}	100 A ⁵⁾
Operating junction temperature – Sperrschichttemperatur Storage temperature – Lagerungstemperatur		T _j T _s	-50...+175°C -50...+175°C

Characteristics

Kennwerte

Max. instantaneous forward voltage Augenblickswert der Durchlass-Spannung	I _F = 25 A T _j = 25°C	V _{BR} ≤ 200 V V _{BR} > 200 V	V _F	< 3.0 V ⁵⁾ < 6.5 V ⁵⁾
Typical thermal resistance junction to ambient Typischer Wärmewiderstand Sperrschicht – Umgebung			R _{thA}	45 K/W ⁴⁾
Typical thermal resistance junction to lead Typischer Wärmewiderstand Sperrschicht – Anschlussdraht			R _{thL}	15 K/W

- Please note the [detailed information on our website](#) or at the beginning of the data book
Bitte beachten Sie die [detaillierten Hinweise auf unserer Internetseite](#) bzw. am Anfang des Datenbuches
- T_A = 25°C unless otherwise specified – T_A = 25°C wenn nicht anders angegeben
- Non-repetitive pulse see curve I_{pp} = f(t) / P_{pp} = f(t)
Höchstzulässiger Spitzenwert eines einmaligen Impulses, siehe Kurve I_{pp} = f(t) / P_{pp} = f(t)
- Valid, if leads are kept at ambient temperature at a distance of 10 mm from case
Gültig, wenn die Anschlussdrähte in 10 mm Abstand vom Gehäuse auf Umgebungstemperatur gehalten werden
- Unidirectional diodes only – Nur für unidirektionale Dioden

Characteristics ($T_j = 25^\circ\text{C}$)

 Kennwerte ($T_j = 25^\circ\text{C}$)

Type Typ BZW06-		Stand-off voltage Sperrspannung	Max. rev. current Max. Sperrstrom at / bei V_{WM}	Breakdown voltage at $I_T = 1\text{ mA}$ Abbruch-Spannung bei $I_T = 1\text{ mA}$ *) at / bei $I_T = 10\text{ mA}$		Max. clamping voltage Max. Begrenzer-Spannung at / bei I_{PPM} (10/1000 μs)	
unidirectional	bidirectional	V_{WM} [V]	I_D [μA]	V_{BR} [V]		V_C [V]	I_{PPM} [A]
5V8	5V8B	5.8	1000	$6.8 \pm 5\%$	6.45...7.14 *)	10.5	57
6V4	6V4B	6.4	500	$7.5 \pm 5\%$	7.13...7.88 *)	11.3	53
7V0	7V0B	7.02	200	$8.2 \pm 5\%$	7.79...8.61 *)	12.1	50
7V8	7V8B	7.78	50	$9.1 \pm 5\%$	8.65...9.55	13.4	45
8V5	8V5B	8.55	10	$10 \pm 5\%$	9.5...10.5	14.5	41
9V4	9V4B	9.4	5	$11 \pm 5\%$	10.5...11.6	15.6	38
10	10B	10.2	5	$12 \pm 5\%$	11.4...12.6	16.7	36
11	11B	11.1	5	$13 \pm 5\%$	12.4...13.7	18.2	33
13	13B	12.8	5	$15 \pm 5\%$	14.3...15.8	21.2	28
14	14B	13.6	5	$16 \pm 5\%$	15.2...16.8	22.5	27
15	15B	15.3	5	$18 \pm 5\%$	17.1...18.9	25.2	24
17	17B	17.1	5	$20 \pm 5\%$	19.0...21.0	27.7	22
19/-Q	19B	18.8	5	$22 \pm 5\%$	20.9...23.1	30.6	20
20	20B/-Q	20.5	5	$24 \pm 5\%$	22.8...25.2	33.2	18
23	23B	23.1	5	$27 \pm 5\%$	25.7...28.4	37.5	16
26	26B	25.6	5	$30 \pm 5\%$	28.5...31.5	41.5	14.5
28	28B	28.2	5	$33 \pm 5\%$	31.4...34.7	45.7	13.1
31	31B	30.8	5	$36 \pm 5\%$	34.2...37.8	49.9	12.0
33	33B	33.3	5	$39 \pm 5\%$	37.1...41.0	53.9	11.1
37	37B	36.8	5	$43 \pm 5\%$	40.9...45.2	59.3	10.1
40	40B	40.2	5	$47 \pm 5\%$	44.7...49.4	64.8	9.3
44	44B/-AQ	43.6	5	$51 \pm 5\%$	48.5...53.6	70.1	8.6
48	48B	47.8	5	$56 \pm 5\%$	53.2...58.8	77.0	7.8
53	53B	53.0	5	$62 \pm 5\%$	58.9...65.1	85.0	7.1
58	58B	58.1	5	$68 \pm 5\%$	64.6...71.4	92.0	6.5
64	64B	64.1	5	$75 \pm 5\%$	71.3...78.8	103	5.8
70	70B	70.1	5	$82 \pm 5\%$	77.9...86.1	113	5.3
78	78B	77.8	5	$91 \pm 5\%$	86.5...95.5	125	4.8
85	85B	85.8	5	$100 \pm 5\%$	95.0...105	137	4.4
94	94B	94.0	5	$110 \pm 5\%$	105...116	152	3.9
102	102B	102	5	$120 \pm 5\%$	114...126	165	3.6
111	111B	111	5	$130 \pm 5\%$	124...137	179	3.4
128	128B	128	5	$150 \pm 5\%$	143...158	207	2.9
136	136B	136	5	$160 \pm 5\%$	152...168	219	2.7
145	145B	145	5	$170 \pm 5\%$	162...179	234	2.6
154	154B	154	5	$180 \pm 5\%$	171...189	246	2.4
171	171B	171	5	$200 \pm 5\%$	190...210	274	2.2
188	188B	188	5	$220 \pm 5\%$	209...231	301	2.0
213	213B	213	5	$250 \pm 5\%$	237...263	344	1.8
239	239B	239	5	$280 \pm 5\%$	266...294	384	1.7
256	256B	256	5	$300 \pm 5\%$	285...315	414	1.6
273	273B	273	5	$320 \pm 5\%$	304...336	438	1.6
299	299B	299	5	$350 \pm 5\%$	332...368	482	1.6
342	342B	342	5	$400 \pm 5\%$	380...420	548	1.3
376	376B	376	5	$440 \pm 5\%$	418...462	603	1.3

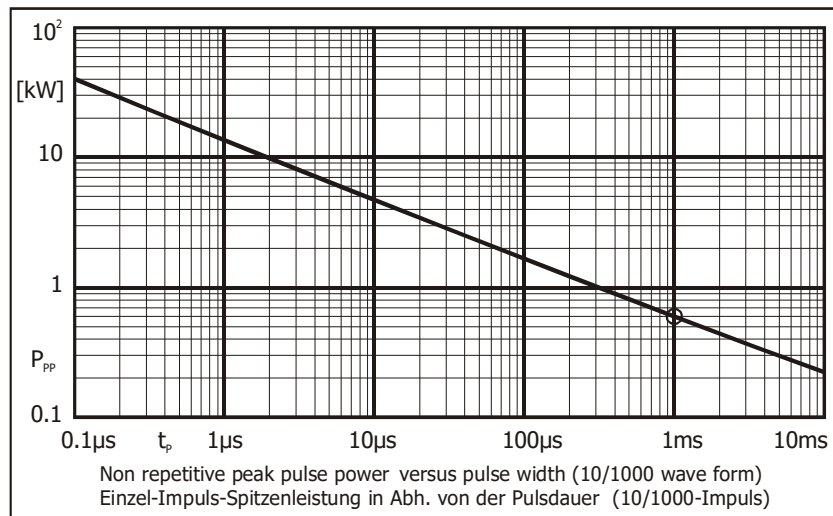
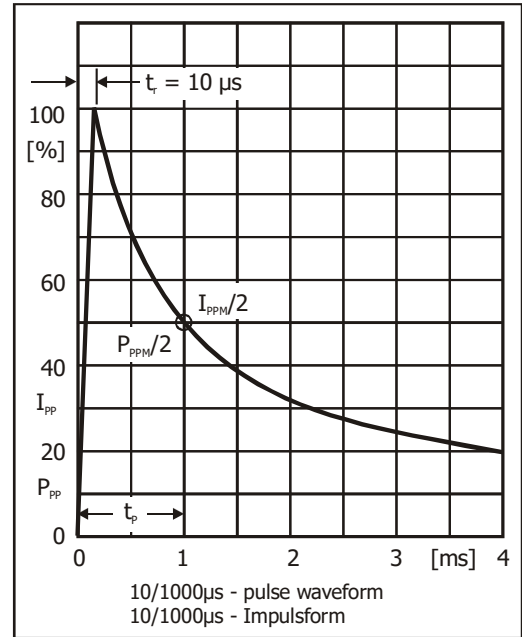
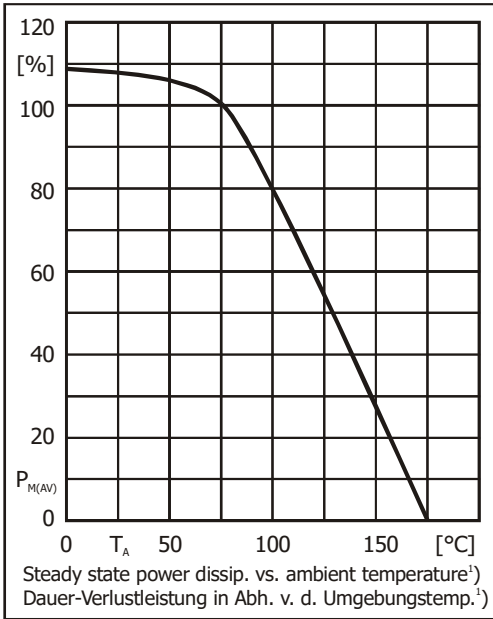

Disclaimer: See data book page 2 or [website](#)
Haftungsausschluss: Siehe Datenbuch Seite 2 oder [Internet](#)

1 Valid, if leads are kept at ambient temperature at a distance of 10 mm from case
 Gültig, wenn die Anschlussdrähte in 10 mm Abstand von Gehäuse auf Umgebungstemperatur gehalten werden