

DF2005S-G Thru. DF210S-G

Reverse Voltage: 50 to 1000V

Forward Current: 2.0A

RoHS Device

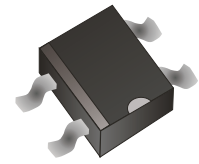

Features

- Rating to 1000V PRV
- Ideal for printed circuit board
- Low forward voltage drop,high current capability
- Reliable low cost construction utilizing molded plastic technique results in inexpensive product
- The plastic material has UL flammability classification 94V-0

Mechanical Data

- Polarit:As marked on Body
- Weight:0.02 ounces, 0.38 grams
- Mounting position:Any

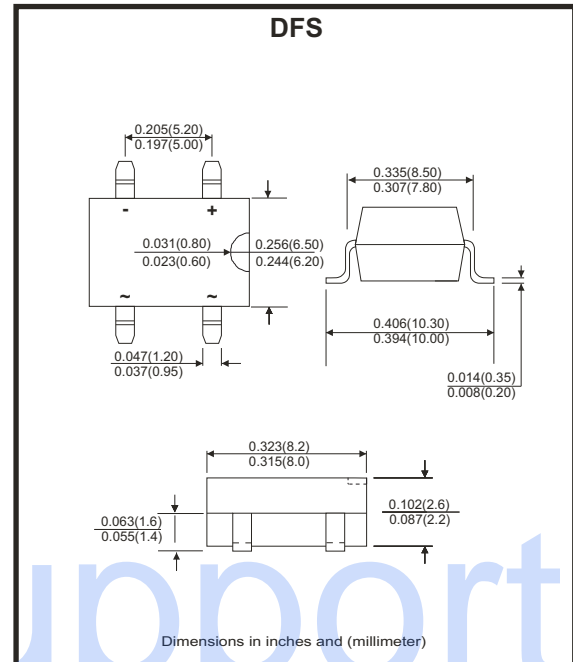

Maximum ratings and electrical characteristics

Rating at 25°C ambient temperature unless otherwise specified.

Single phase, half wave ,60Hz, resistive or inductive load.

For capacitive load, derate current by 20%

Parameter	Symbol	DF2005S-G	DF201S-G	DF202S-G	DF204S-G	DF206S-G	DF208S-G	DF210S-G	Unit
Maximum Reverse Peak Repetitive Voltage	V_{RRM}	50	100	200	400	600	800	1000	V
Maximum RMS Voltage	V_{RMS}	35	70	140	280	420	560	700	V
Maximum DC Blocking Voltage	V_{DC}	50	100	200	400	600	800	1000	V
Maximum Average Forward Rectified Current @ $T_A=40^{\circ}C$	$I_{(AV)}$	2.0							A
Peak Forward Surge Current , 8.3ms Single Half Sine-Wave Super Imposed on Rated Load	I_{FSM}	60							A
$I^2 t$ Rating for Fusing ($t < 8.3ms$)	$I^2 t$	10.4							$A^2 s$
Maximum Forward Voltage at 2.0A DC	V_F	1.1							V
Maximum DC Reverse Current @ $T_J = 25^{\circ}C$ at Rated DC Blocking Voltage @ $T_J = 125^{\circ}C$	I_R	10 500							μA
Typical Junction Capacitance Per Element (Note 1)	C_J	25							pF
Typical Thermal Resistance (Note 2)	$R_{\theta JA}$	40							$^{\circ}C/W$
Operating Temperature Range	T_J	-55 ~ +150							$^{\circ}C$
Storage Temperature Range	T_{STG}	-55 ~ +150							$^{\circ}C$

Notes:

1. Measured at 1.0MHz and applied reverse voltage of 4.0V DC
2. Unit mounted on P.C.B with 0.50"×0.50" (13×13mm) copper pads.

Rating and Characteristics Curves (DF2005S-G Thru. DF210S-G)

FIG. 1-Derating Curve For Output Rectified Current

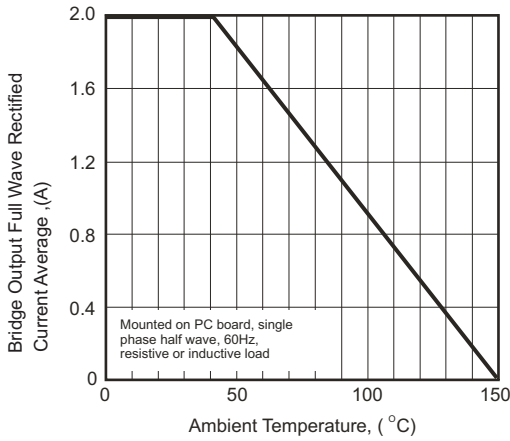

FIG. 2-Maximum Non-Repetitive Peak Forward Surge Current

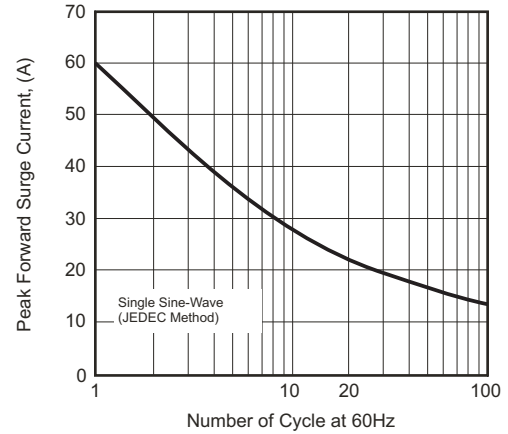

Fig.3- Typical Junction Capacitance

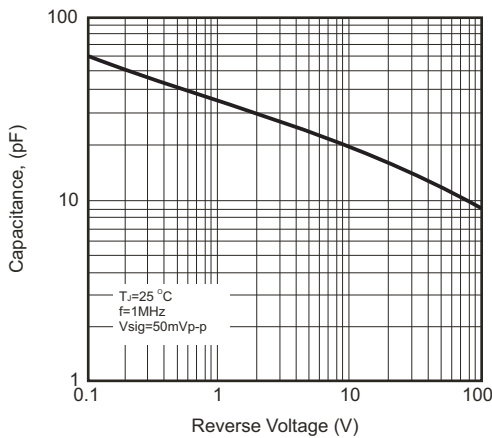

Fig.4- Typical Forward Characteristics

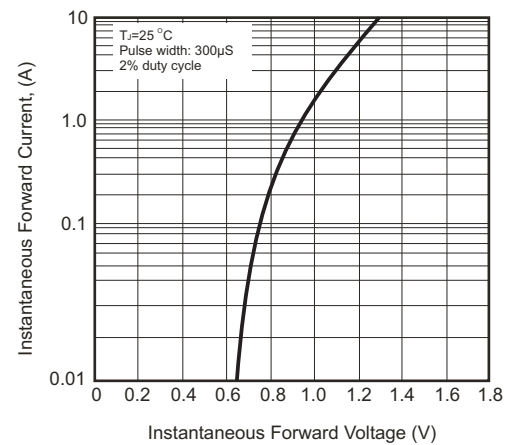
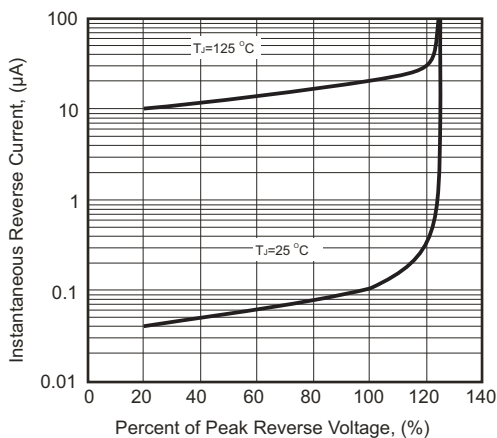
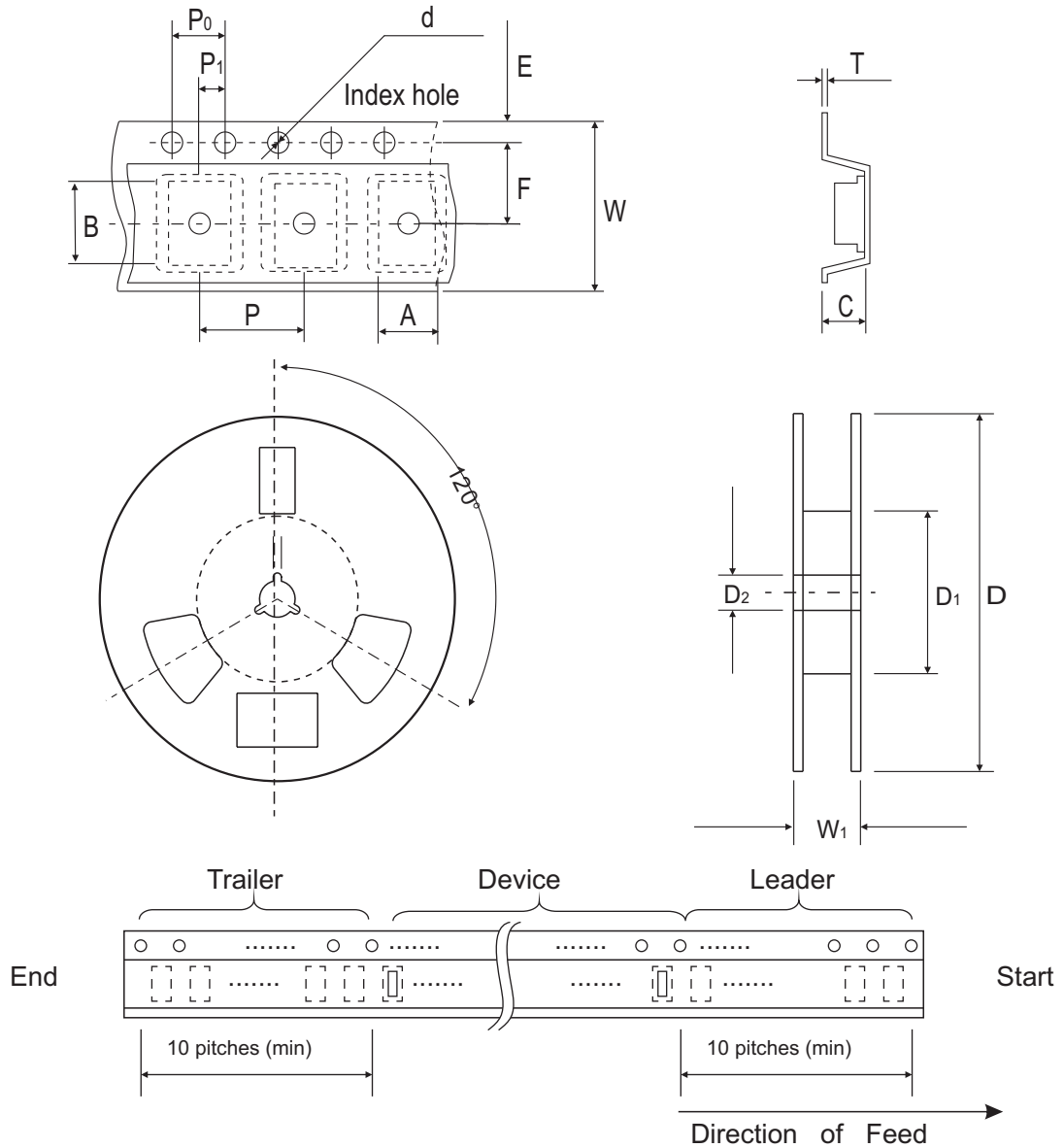

Fig.5- Typical Reverse Characteristics



Reel Taping Specification



DFS	SYMBOL	A	B	C	d	D	D ₁	D ₂
	(mm)	8.64 ± 0.10	10.41 ± 0.10	3.81 ± 0.10	1.55 ± 0.10	330	50.0 Min	13.0 ± 0.20
	(inch)	0.340 ± 0.004	0.409 ± 0.004	0.150 ± 0.004	0.061 ± 0.004	13.00	1.969 Min	0.512 ± 0.008

DFS	SYMBOL	E	F	P	P ₀	P ₁	W	W ₁
	(mm)	1.75 ± 0.10	7.50 ± 0.05	12.00 ± 0.10	4.00 ± 0.10	2.00 ± 0.10	16.0 ± 0.30	16.00~18.40
	(inch)	0.069 ± 0.004	0.295 ± 0.002	0.472 ± 0.004	0.157 ± 0.004	0.079 ± 0.004	0.630 ± 0.012	0.630~0.724

Marking Code

Part Number	Marking code	Packaging
DF2005S-G	DF2005S	Tube
DF201S-G	DF201S	Tube
DF202S-G	DF202S	Tube
DF204S-G	DF204S	Tube
DF206S-G	DF206S	Tube
DF208S-G	DF208S	Tube
DF210S-G	DF210S	Tube
DF2005ST-G	DF2005S	Reel
DF201ST-G	DF201S	Reel
DF202ST-G	DF202S	Reel
DF204ST-G	DF204S	Reel
DF206ST-G	DF206S	Reel
DF208ST-G	DF208S	Reel
DF210ST-G	DF210S	Reel

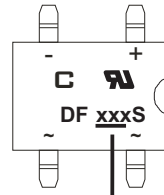

XXX / XXXX = Product type marking code
 C = Comchip Logo

Suggested PAD Layout

SIZE	DFS	
	(mm)	(inch)
A	1.20 Min	0.047 Min
B	5.21 REF	0.205 REF
C	1.52 Min	0.060 Min
D	10.26 Max	0.404 Max

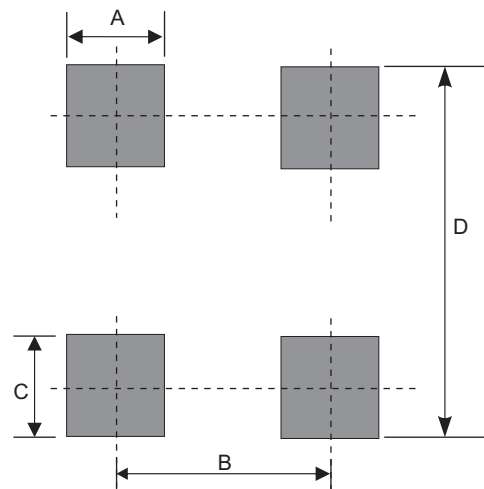

Standard Package

Case Type	REEL PACK			
	REEL (EA)	Reel / Carton (EA)	CARTON (EA)	Reel Size (inch)
DFS	1,000	12	12,000	13

Case Type	TUBE PACK		
	TUBE (EA)	BOX (EA)	CARTON (EA)
DFS	50	5,000	30,000