

INCH-POUND

MS3112H
1 March 2007
SUPERSEDING
MS3112G
30 July 1979

DETAIL SPECIFICATION SHEET

CONNECTORS, RECEPTACLE, ELECTRICAL, BOX MOUNTING,
FLANGE, BAYONET COUPLING, SOLDER CONTACT, SERIES 1

Inactive for new design after 15 December 1998. For new design, use MS3470.

This specification is approved for use by all Departments and Agencies of the Department of Defense.

The requirements for acquiring the product described herein shall consist of this specification sheet and MIL-DTL-26482.

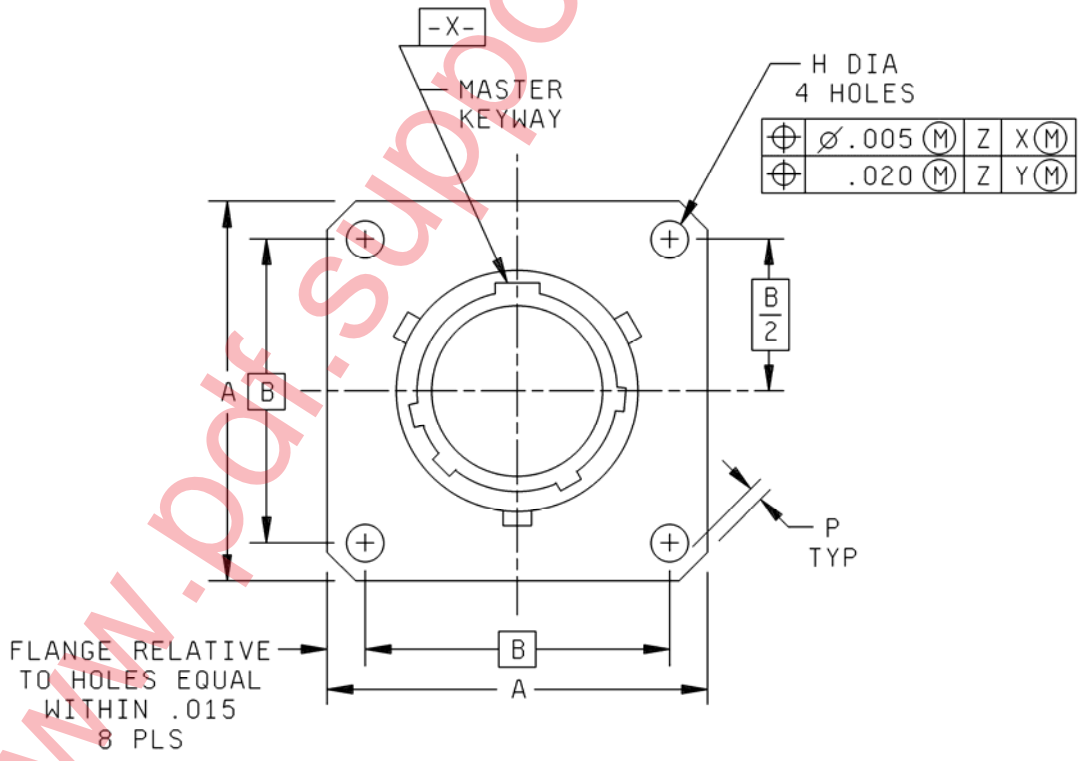

FIGURE 1. Receptacle.

MS3112H

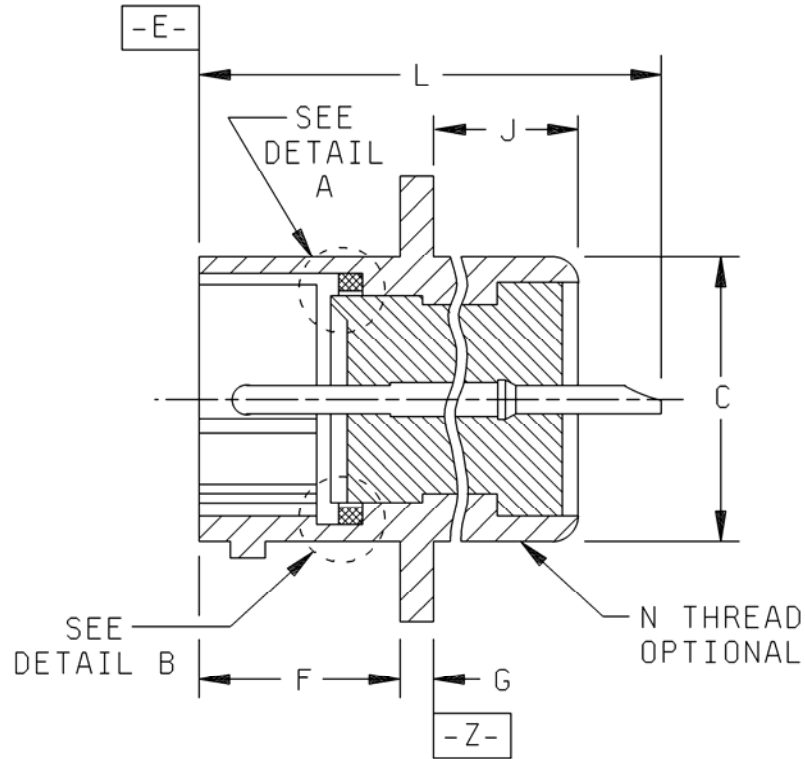

FIGURE 1. Receptacle - Continued.

MS3112H

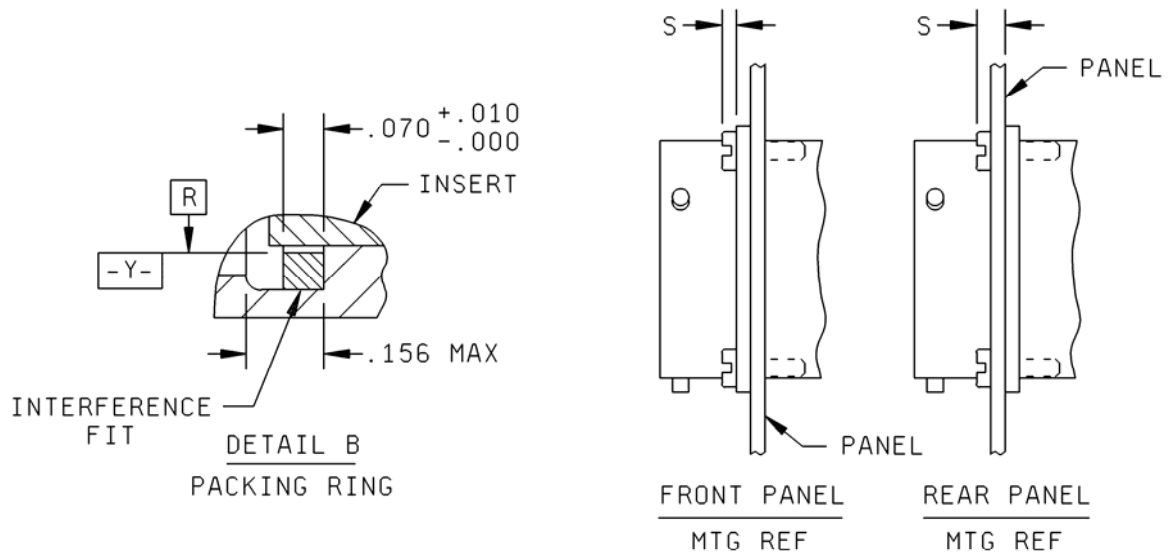
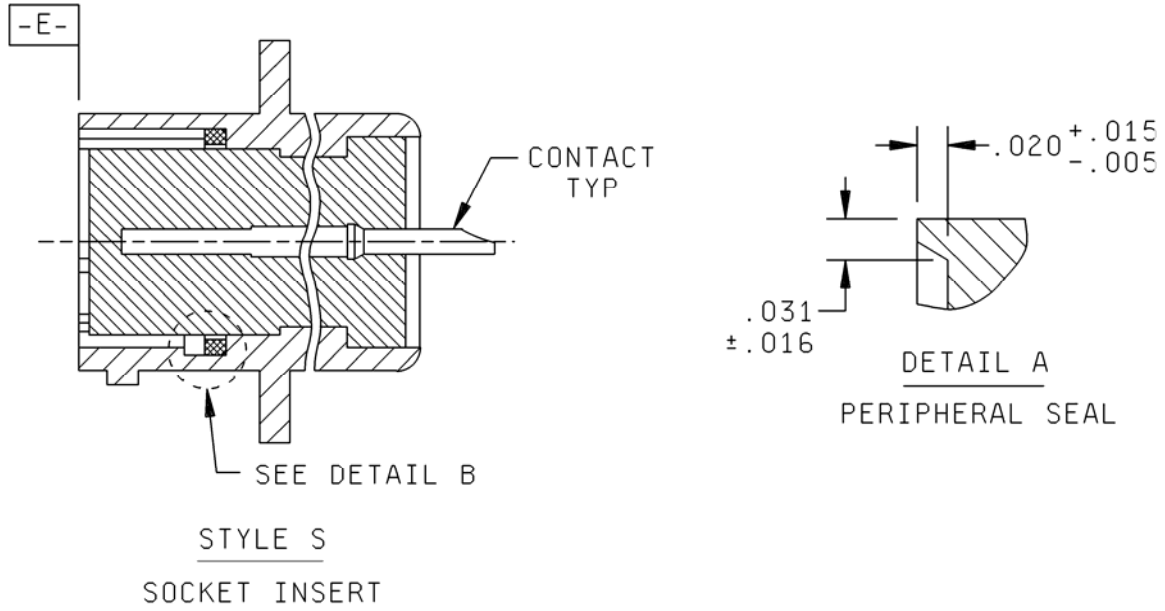

FIGURE 1. Receptacle - Continued.

MS3112H

Shell size	A max length	B (TP) ⌀ - ⌀ mounting holes	C + .031 - .016 OD	F + .031 - .000 mounting flange location	G ± .016 thick mounting flange	H ± .005 dia mounting holes
8	.828 (21.03)	.594 (15.09)	.438 (11.12)	.431 (10.95)	.062 (1.57)	.120 (3.05)
10	.954 (24.23)	.719 (18.26)	.562 (14.27)			
12	1.047 (26.59)	.812 (20.62)	.688 (17.48)			
14	1.141 (28.98)	.906 (23.01)	.812 (20.62)			
16	1.234 (31.34)	.969 (24.61)	.938 (23.83)			
18	1.328 (33.73)	1.062 (26.97)	1.062 (26.97)			
20	1.453 (36.91)	1.156 (29.36)	1.188 (30.18)	.556 (14.12)	.094 (2.39)	.147 (3.73)
22	1.578 (40.08)	1.250 (31.75)	1.312 (33.32)			
24	1.703 (43.26)	1.375 (34.93)	1.438 (36.53)	.589 (14.96)		

Shell size	J max	L max overall length	N UNEF-2A thread optional	P min edge distance	R max packing ring	S max
8	.354 (8.99)	.978 (24.84)	.4375-28	.035 (0.89)	.329 (8.36)	.087 (2.21)
10			.5625-24		.457 (11.61)	
12			.6875-24		.564 (14.33)	
14			.8125-20		.689 (17.50)	
16			.9375-20		.814 (20.68)	
18			1.0625-18		.907 (23.04)	
20	.417 (10.59)	1.196 (30.38)	1.1875-18	.050 (1.27)	1.039 (26.39)	.212 (5.38)
22			1.3125-18		1.164 (29.57)	
24			1.4375-18		1.289 (32.74)	

FIGURE 1. Receptacle - Continued.

MS3112H

Inches	mm	Inches	mm
.005	0.13	.020	0.51
.010	0.25	.031	0.79
.015	0.38	.070	1.78
.016	0.41	.156	3.96

NOTES:

1. Dimensions are in inches. Metric equivalents are given for information only.
2. True position (TP) tolerances specified are in accordance with ASME Y14.5M.

FIGURE 1. Receptacle - Continued.

REQUIREMENTS:

Dimensions and configurations: See figure 1.

Connector mating: This connector mates with MS3111, MS3116, MS3121 and MS3126.

For insert arrangement: See MIL-STD-1669.

Intermateability dimensions are in accordance with MIL-DTL-26482.

Part or Identifying Number (PIN) example:

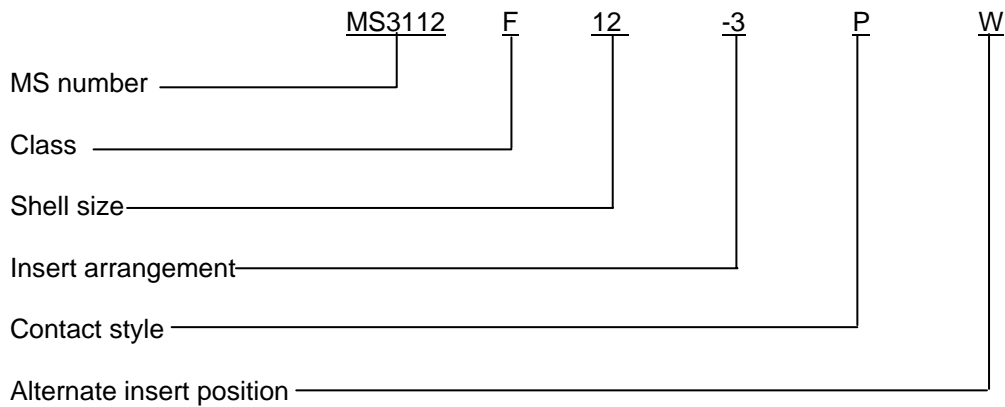

Changes from previous issue. Marginal notations are not used in this revision to identify changes with respect to the previous issue due to the extent of the changes.

Referenced documents. In addition to MIL-DTL-26482, this document references the following:

- MS3111
- MS3116
- MS3121
- MS3126
- MS3470
- MIL-STD-1669
- ASME Y14.5M

MS3112H

CONCLUDING MATERIAL

Custodians:
Army – CR
Navy – AS
Air Force – 11
DLA – CC

Preparing activity:
DLA – CC

(Project 5935-4656-003)

Review activities:
Army – AV
Navy – SH

NOTE: The activities listed above were interested in this document as of the date of this document. Since organizations and responsibilities can change, you should verify the currency of the information above using the ASSIST Online database at <http://assist.daps.dla.mil>.